

# Hybrid Energy Storage System Controller for Electric Vehicle using Ultracapacitor: Modeling and Performance Analysis

Sarva Ruvinigya Somanshu<sup>1</sup>, S. K. Sinha<sup>2</sup>

PG Student [PED], Dept. of EE, Kamla Nehru Institute of Technology, Sultanpur, Uttar Pradesh, India<sup>1</sup>

Professor, Dept. of EE, Kamla Nehru Institute of Technology, Sultanpur, Uttar Pradesh, India<sup>2</sup>

**ABSTRACT:** The performance analysis of new MATLAB simulink proposed model of hybrid energy storage system (HESS) used in Electric Vehicle using Ultracapacitor (UCEV) presented along with different configuration of converter. In HESS, because of inherent characteristics of high power density and converter configuration the UC will be utilized to absorb or deliver high rate of charge transfer. This results that a relatively constant load profile is created for the battery that is, battery is not used for very high rate of charge transfer which will increase the life of battery plates, less heating of battery and also increase driving range of vehicle.

**KEYWORDS:** Brushless DC motor, Hybrid Energy Storage System (HESS), Electric vehicle technology, MATLAB Simulink, Regenerative Braking System (RBS), AC and DC drives, Ultracapacitor (UC).

## NOMENCLATURE:

<i>EV</i>	Electric Vehicle
<i>ATLS</i>	Anti-theft lock system
<i>BLDC</i>	Brushless DC
<i>RBS</i>	Regenerative Braking System
<i>HEV</i>	Hybrid Electric Vehicle
<i>HESS</i>	Hybrid Energy Storage System
<i>UC</i>	Ultracapacitor

## I.INTRODUCTION

Different converter topologies have been emerged in last few years for the development and implementation of HESS in HEVs [1]-[13].The performance analysis has been presented in different working modes like constant low speed operation, constant high speed operation, acceleration mode and regenerative braking mode. Controller configuration discussed along with resulting waveforms of different parameters.

### A. INVERTER AND MOTOR SECTION

A three-phase, six-step inverter used in proposed model taken from MATLAB library. Parameters of inverter is given below-

No. of bridge arm	3
Switching device	MOSFET

Snubber capacitance	1 $\mu$ F
Snubber resistance	5 k $\Omega$

Ron	1 m $\Omega$
-----	--------------

## International Journal of Innovative Research in Science, Engineering and Technology

(An ISO 3297: 2007 Certified Organization)

Vol. 5, Issue 12, December 2016

Hall sensor signal is converted into emf of a, b and c coil. Based on different condition that signal gives gate signal for inverter gate terminal. If  $h_a, h_b, h_c$  are hall sensor signal and the  $emf_a, emf_b, emf_c$  are emf of a, b and c coil of BLDC motor, then according to condition which given in fig. 1 the gate signal (Q1-Q6) of inverter decided as shown below-

$h_a$	$h_b$	$h_c$	$emf_a$	$emf_b$	$emf_c$	Q1	Q2	Q3	Q4	Q5	Q6
0	0	0	0	0	0	0	0	0	0	0	0
0	0	1	0	-1	+1	0	0	0	1	1	0
0	1	0	-1	+1	0	0	1	1	0	0	0
0	1	1	-1	0	+1	0	1	0	0	1	0
1	0	0	+1	0	-1	1	0	0	0	0	1
1	0	1	+1	-1	0	1	0	0	1	0	0
1	1	0	0	+1	-1	0	0	1	0	0	1
1	1	1	0	0	0	0	0	0	0	0	0

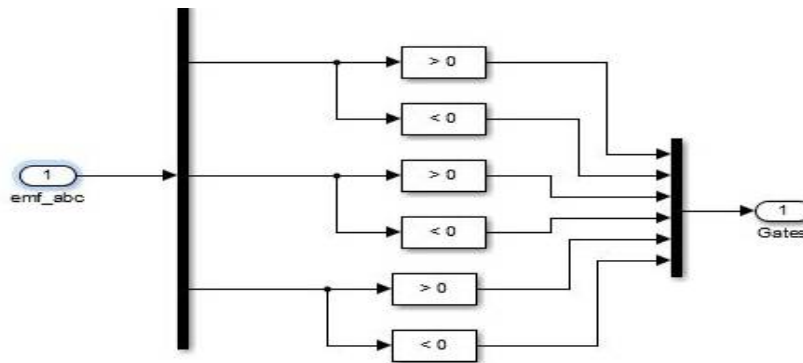

Fig. 1 emf signal to gate signal conversion

BLDC motor, also called permanent magnet synchronous machine. In MATLAB library it is available with sinusoidal as well as trapezoidal back emf with 3-phase and 5-phase system. It works as motor as well as generator with positive and negative applied mechanical torque respectively.

The parameters for this model which have been chosen for motor given below-

Motor type	PM-BLDC	Pole pairs	5	Stator phase resistance	2.8750 $\Omega$
No. of phases	3	Flux linkage	0.175	Back EMF waveform	Trapezoidal
Stator phase inductance	8.5 mH				

If anyone require more torque by motor at same input, simply change the no. of pole pairs. More the pole pairs develop more torque. Parameters taken for analysis are-

Battery Panel	340V, 261Ah	Buck-Boost Converter	300mH, 567 $\mu$ F, 21.5 k $\Omega$ , 0.002 sec period, 72% duty cycle
UC Panel	375V, 15.6F		
Speed	100rad/s		

# International Journal of Innovative Research in Science, Engineering and Technology

(An ISO 3297: 2007 Certified Organization)

Vol. 5, Issue 12, December 2016

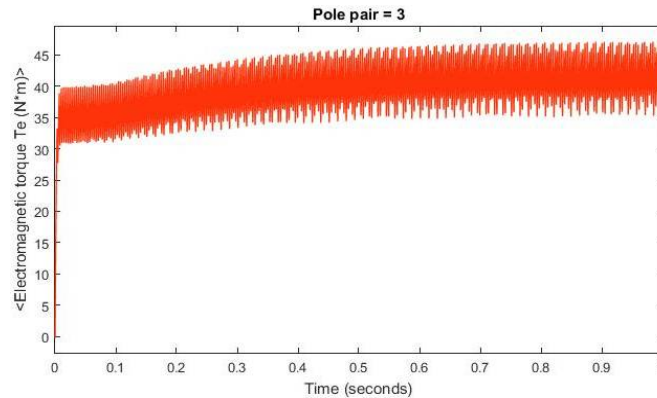

(a)

The average value of torque for pole pair 3 is nearly 40 N-m, again this motor run with same input except having pole number. In the next simulation test, model has been run with pole pair set to 4 and obtained waveform shown below-

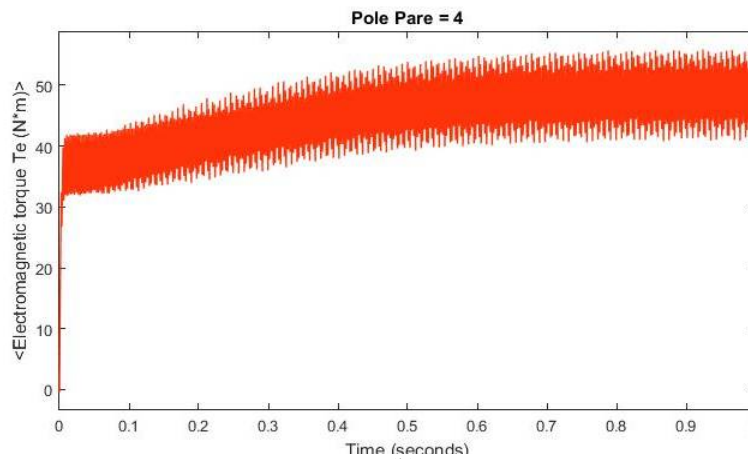

(b)

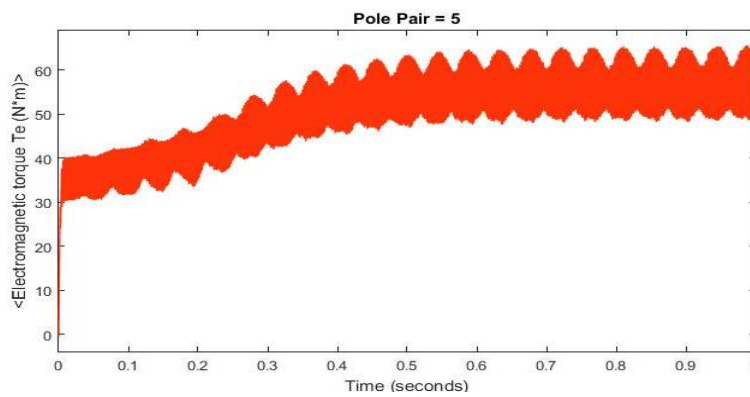

(c)

Fig. 2 Torque at different no. pole pair & other parameter kept same

Figure 2 shows the variation of torque value with change in number of pole pair of BLDC motor keeping other parameter same.

# International Journal of Innovative Research in Science, Engineering and Technology

(An ISO 3297: 2007 Certified Organization)

Vol. 5, Issue 12, December 2016

## B. SWITCHING CONTROLLER SECTION

This section's main component is buck-boost converter and switches, controlled by switching controller algorithm. Buck-Boost converter is operated at 72% duty cycle (greater than 50%), so it works in boost mode only and it is used to maintain voltage level and current level as per demand, it is sensed by switching controller on behalf of different drives condition parameter. Boost circuit parameters already given. Configuration of controller Section shown below in fig. 3.

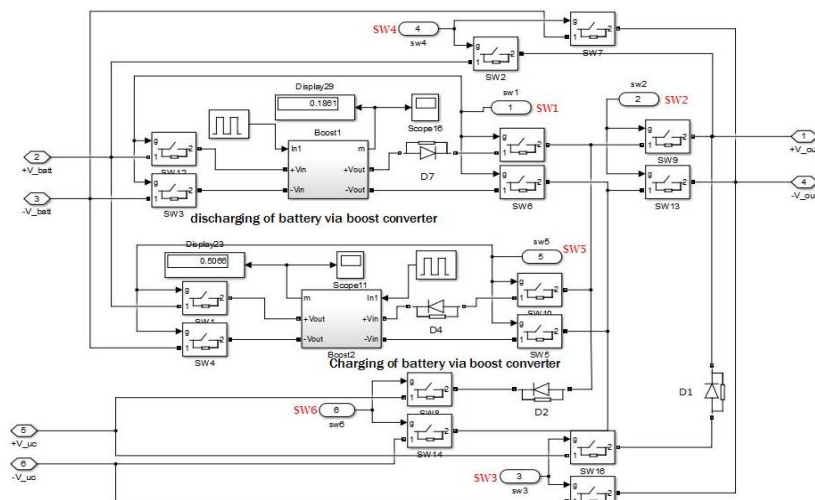

Fig. 3 MATLAB model of switching controller circuit

## C. CONTROLLER SECTION

Controller block basically detects real time signals as input and accordingly gives output to different switches. MATLAB Function block named 'controller', contains this algorithm to perform this action.

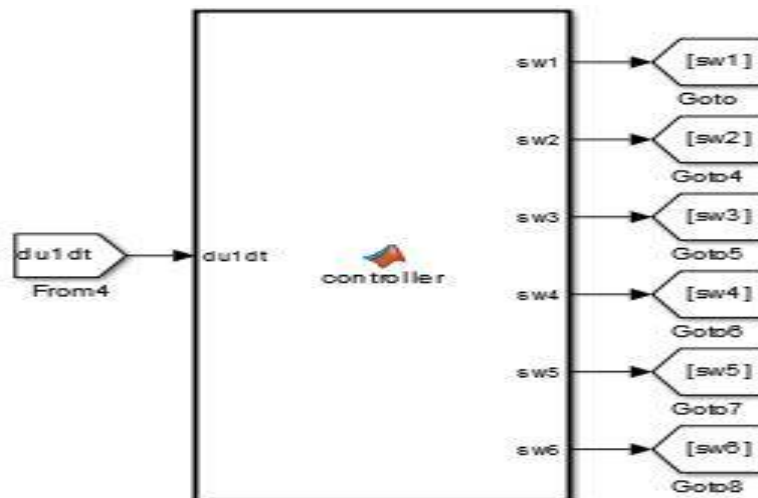

Fig. 4 MATLAB Function block of controller

# International Journal of Innovative Research in Science, Engineering and Technology

(An ISO 3297: 2007 Certified Organization)

Vol. 5, Issue 12, December 2016

The switching pattern for different driving condition is given in table 1.

Table 1  
Switching Pattern for different condition  
Constant Low/High speed Operation switching pattern

Constant Low/High speed Operation switching pattern				
Sw1	0		Sw4	1
Sw2	0		Sw5	0
Sw3	0		Sw6	0
Acceleration mode switching pattern				
Sw1	1		Sw4	0
Sw2	1		Sw5	0
Sw3	1		Sw6	0
Regenerative mode switching pattern				
Sw1	0		Sw4	0
Sw2	1		Sw5	1
Sw3	0		Sw6	1

#### D. HYBRID ENERGY STORAGE SYSTEM(HESS)

This section consists of array of batteries and UCs. As a replacement for of bulky Lead-acid battery now the array of series-parallel arranged small (usually 1.5V-1.67V per cell) Li-polymer or Li-ion batteries used. Similarly the single unit of UC have rating usually 3.7V, 3400F. So to obtain higher rating these are arranged in series-parallel combination. There are a lot of open-source research papers available which explain why Li-ion batteries and UC became so popular.

#### II.LITERATURE SURVEY

N. Mohan et al. [1], reported several types of converters and load operations along with different control techniques of drive operations. The different classification and basis of classification is also explored in these articles for better understanding of converter interface according to the load requirements. Iqbal Husain [2], gives tremendous description of electric vehicles and also discussed about their designs. A. Emadi et al. published papers on electric vehicles power management and electric vehicle's energy storage systems [3] [4] [5]. In the same field J. Shen et al. [6] has been published a paper. Z.Amjadi [7] and F. Akar et al. [8] both proposed bi-directional energy controller for EVs with different control strategy. J. Lee et al. [9] proposed an algorithm for Series HEV to control the multiple energy sources. Similarly L. Gao et al. [10], M. Ortuzar et al [11], W. Lhomme et al. [12] and A. D. Napoli et al. [13] [14] presented paper on different techniques/controllers for electric and hybrid electric vehicle power management and also control strategy for multiple inputs.

**III. PROPOSED UCEV MODEL**

Fig. 5 shows block diagram and Fig. 6 shows simulink model of proposed UCEV.

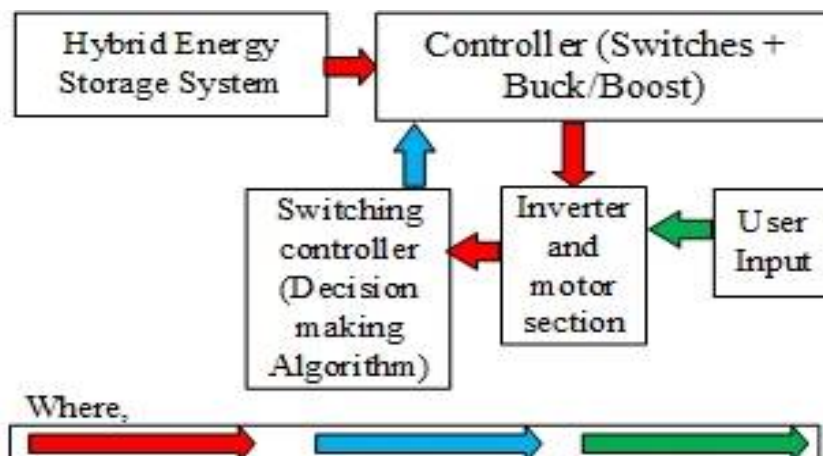

Fig. 5 Block diagram of proposed UCEV model

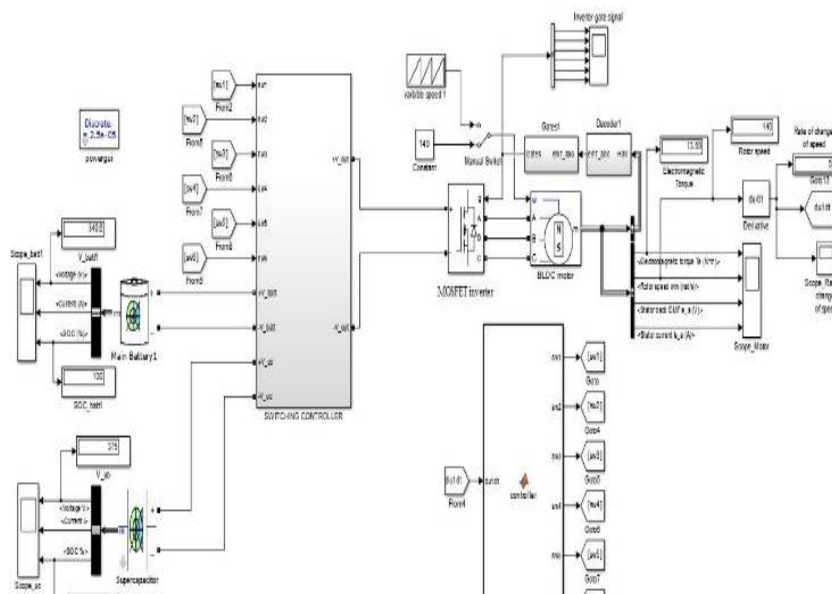

Fig. 6 MATLAB Simulink of proposed UCEV model

**IV. PERFORMANCE STUDY OF PROPOSED UCEV MODEL**

Performance analysis of proposed HESS controller for UCEV model has been done in different condition and working modes in MATLAB environment. Main concern of this research paper is to design an advanced smart converter which provide better HESS for EV.

**A. CONSTANT LOW SPEED OPERATION**

In this mode there is no requirement of boost voltage so only battery is treated as power source. The converter configuration for this mode shown in Fig. 7.

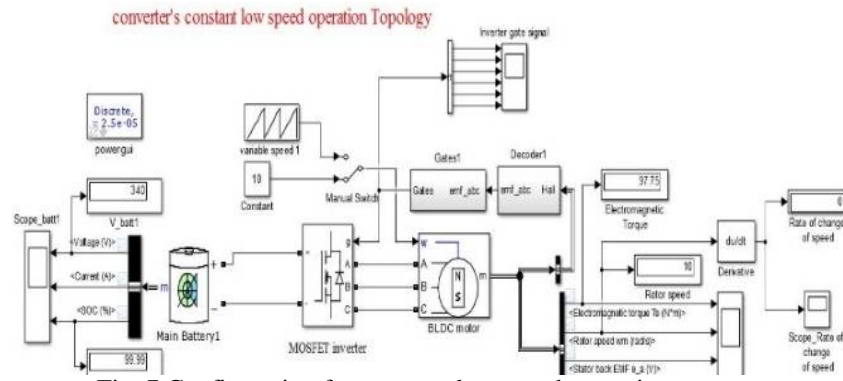
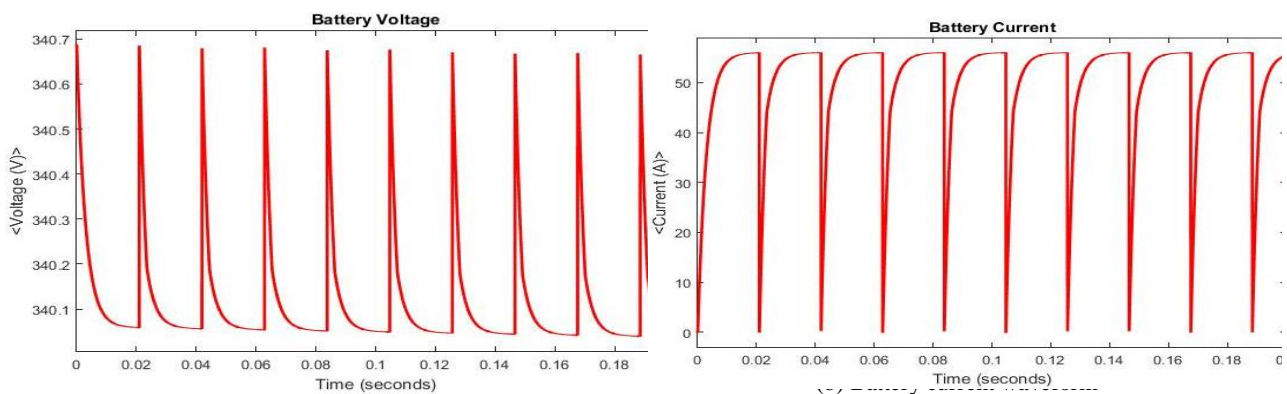

Fig. 7 Configuration for constant low speed operation

The waveform of battery, motor and inverter parameters are shown below-



Above fig. 8(a) and fig. 8(b) shows that battery voltage and battery current waveforms are smooth. At low speed operation (below 30km/hour assumed low speed) there is no need of ultracapacitor because there is no need of high rate of charge transfer.

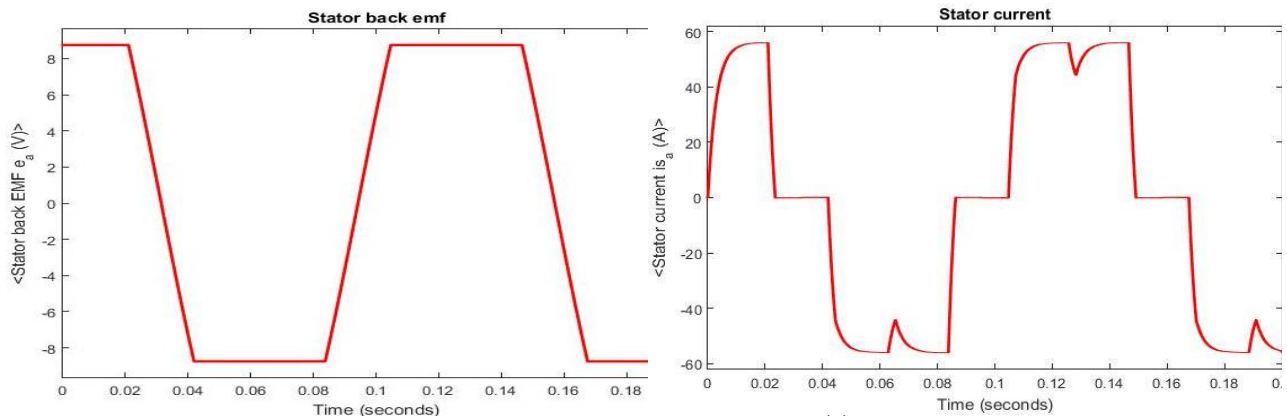

Fig. 8(c) shows that back emf waveform of PMSM motor which has been selected as trapezoidal while parameter setting, is obtained trapezoidal as expected. Similarly fig.8(d) shows that stator current waveform is under acceptable limit. A closed view of both waveform is shown.

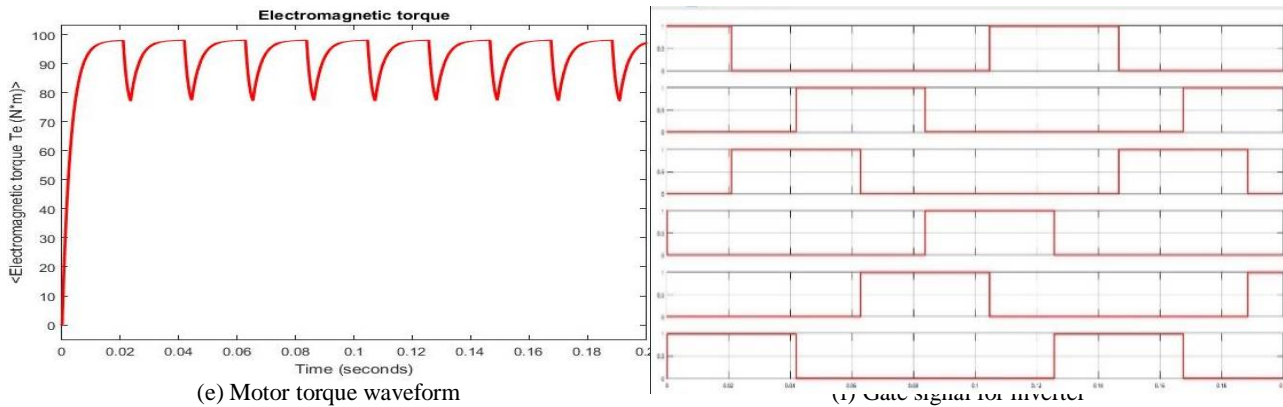

Fig. 8 Waveforms for constant low speed operation

Fig. 8(e) shows that torque waveform of PMSM motor is nearly 90 N-m, and this small fluctuation shown in closed view of waveform. It is under acceptable limit. Similarly fig. 8(f) shows waveform of gate signal generated for inverter operation.

**B. CONSTANT HIGH SPEED OPERATION**

In this mode also there is no requirement of boost voltage so only battery is treated as power source. The converter configuration for this mode shown in fig. 9.

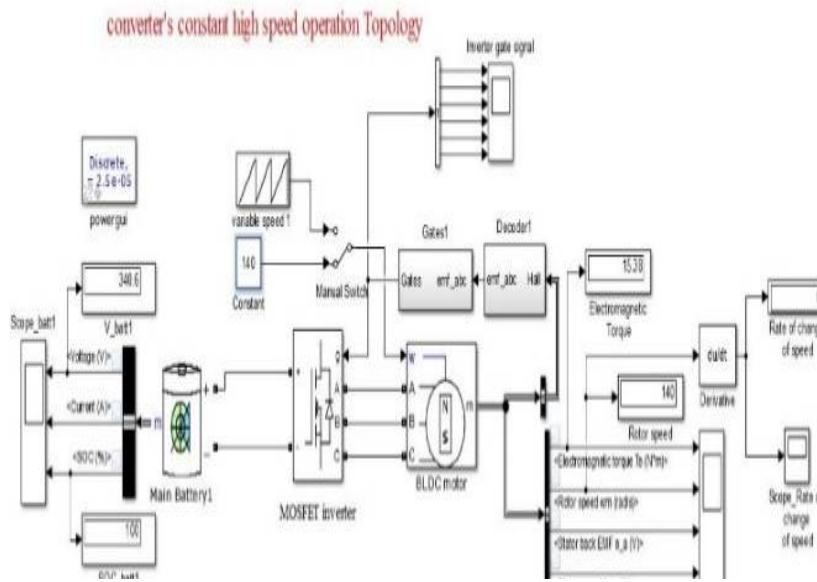
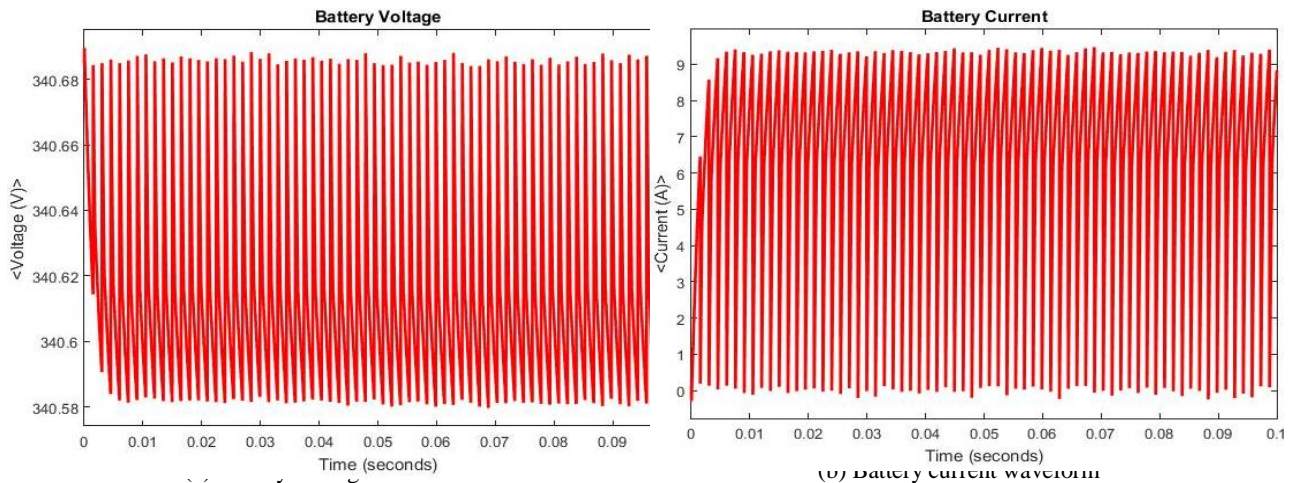

Fig. 9 Configuration for constant high speed operation

The waveforms of battery, motor and inverter parameters for this operating mode are shown below-





Above fig. 10(a) shows that avg. battery voltage is nearly 340.64V, and there is very small fluctuation about 0.10V in 340V is obtained which can be neglected. Because the waveform is taken as closed sectional view so the variation is observable. And in fig. 10(b) battery current waveforms shows that maximum value of current is 9A.

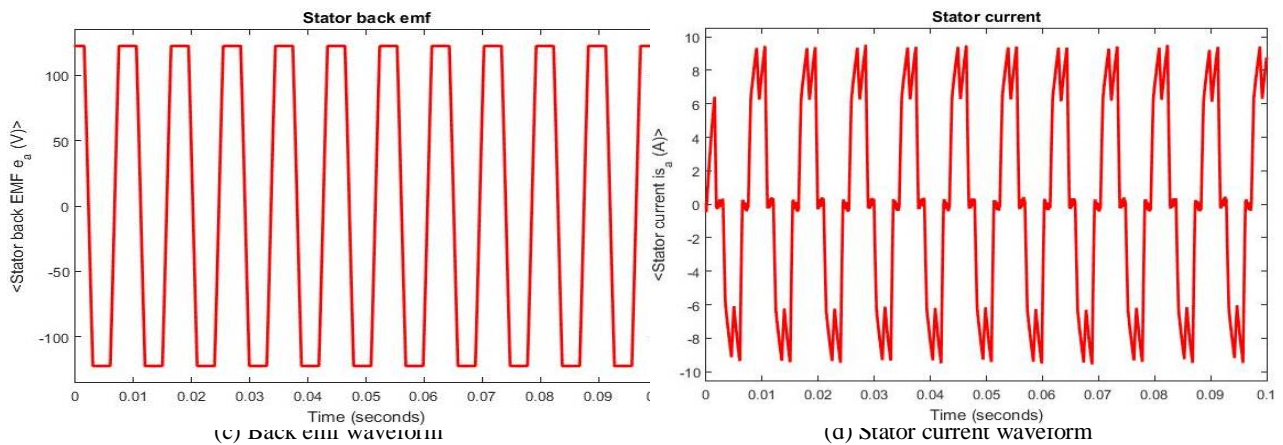

Above fig. 10(c) shows that under constant high speed operation stator torque is smooth and the time period of pulse is reduced as compare to previous constant low speed case. Fig. 10(d) shows stator current waveform shows the same effect in compare to previous case i.e. time period reduced.

Below fig. 10(e) shows that avg. value of motor torque is nearly 14 N-m, and fluctuation occurred in waveform is for very short span on time scale as well as on amplitude scale. Fig. 10(f) shows the signal fed to inverter gate for switching operation.

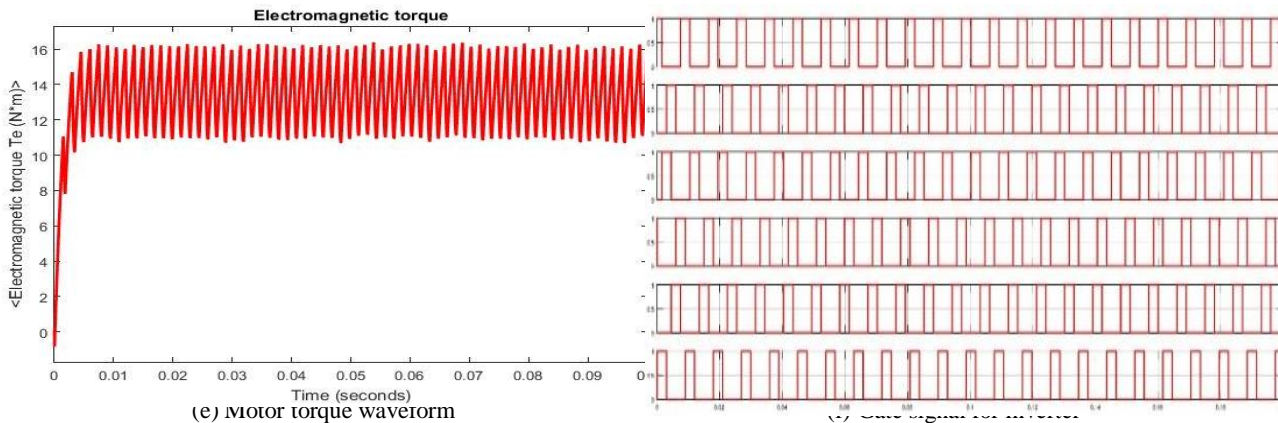

Fig. 10 Waveforms for constant high speed operation

**C. ACCELERATION MODE OPERATION**

In this mode battery as well as UC both sources provide power to the motor, because when motor works in accelerating mode then it require large rate of charge transfer. So the converter configuration for accelerating mode operation of UCEV shown below-

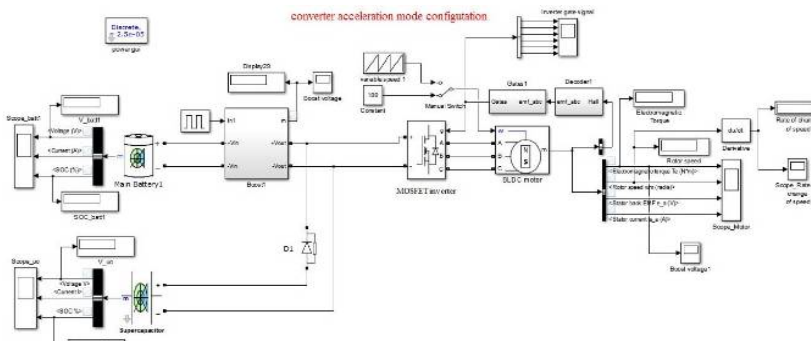

Fig. 11 Configuration for acceleration mode operation

The speed for acceleration mode is taken from look-up table, and given to motor speed port. The speed value with respect to time shown below-

Parameters	
Time values:	[0 1 2 3 4 5]
Output values:	[0 25 60 80 120 140]

Fig. 12 Speed pattern for acceleration mode operation

The waveforms of battery, motor and inverter parameters for this operating mode are shown below-

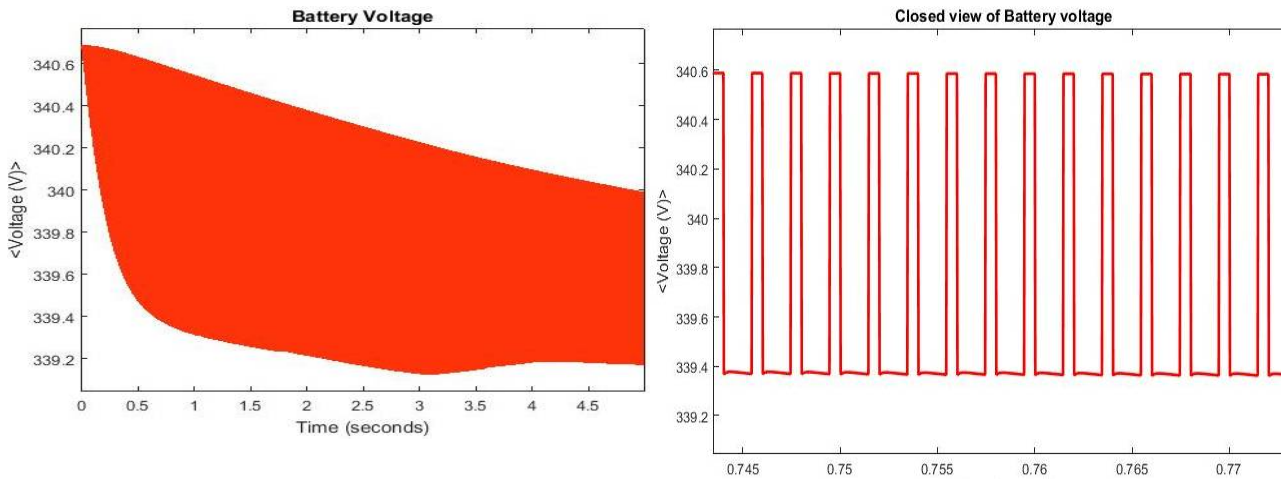

(a) Battery Voltage waveform

Above fig. 13(a) shows the battery voltage waveform under acceleration mode and closed view of this waveform is also shown along with this. It shows that waveform is smooth and almost ripple free.

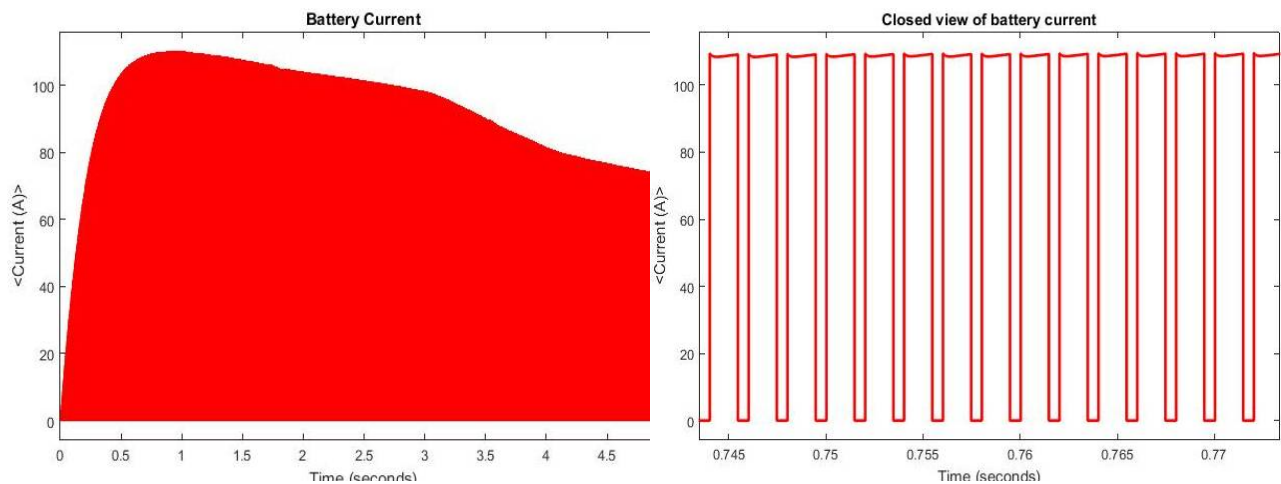

(b) Battery current waveform

Above fig. 13(b) shows the battery current waveform under acceleration mode and closed view of this waveform is also shown along with this. It shows that waveform is smooth and almost ripple free.

In acceleration mode, the purpose of ultracapacitor will be shown in next waveform. At the same time when both input sources get connected then by virtue of acceleration mode effect of load (motor) will affect the performance of source (input electrical source), but the ultracapacitor will absorb the transient because of inherent characteristic and that is why battery performance will be almost unaffected.

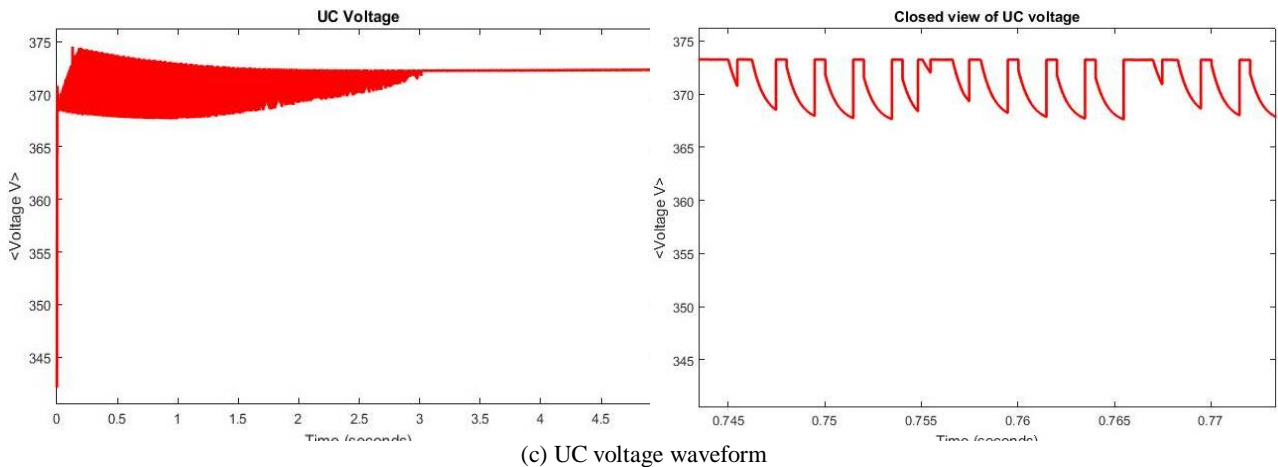

Above waveform of UC voltage shows that from starting to 3 second ripples are presented, but as per construction UC is so rugged and there is nothing so serious for UC. Ripples can be observe clearly in closed waveform of UC voltage.

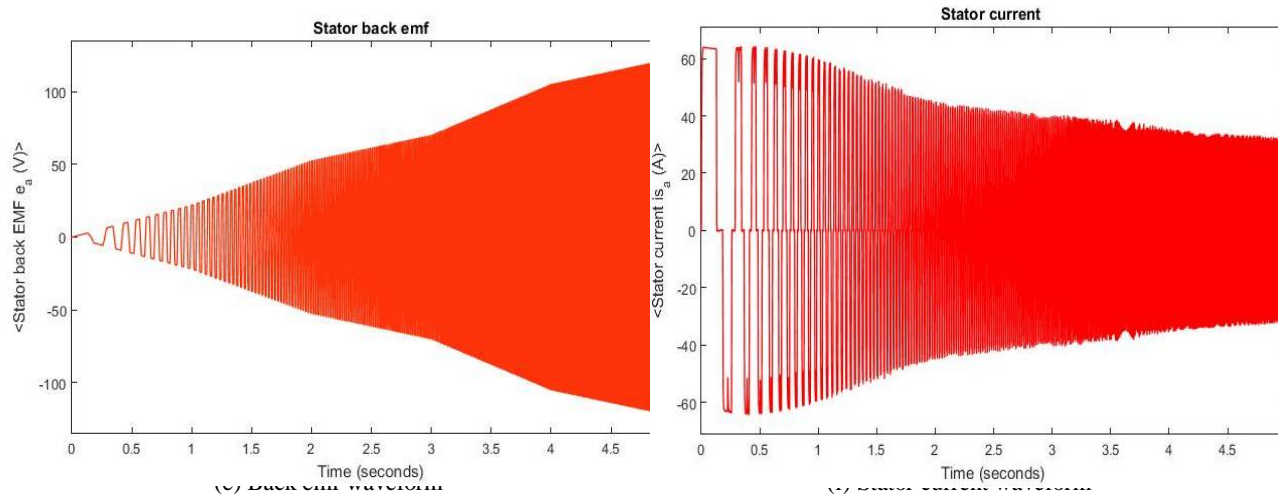

Fig. 13(e) shows the motor back emf waveform, it shows that as the speed increases, the frequency of emf waveform increases (i.e. time period decreases) and emf magnitude is increases. Fig. 13(f) shows the stator current waveform, as speed increases the magnitude of current decreases and frequency of current cycle is increases.

Below fig. 13(e) shows that motor torque reduces with increase of speed. Fluctuation in torque is low and it became lesser as speed increases. Fig. 13(f) shows the signal fed to inverter gate for switching operation.

# International Journal of Innovative Research in Science, Engineering and Technology

(An ISO 3297: 2007 Certified Organization)

Vol. 5, Issue 12, December 2016

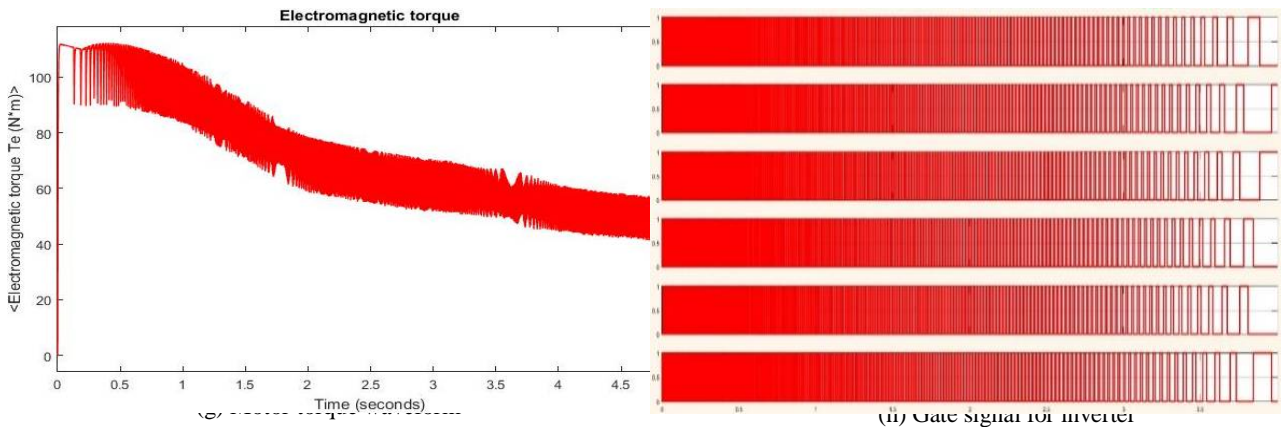

Fig. 13 Waveforms for acceleration mode operation

### D. REGENERATIVE MODE OPERATION

In this mode battery as well as UC both sources connected to the motor but this time power flow opposite to acceleration mode. It is similar to braking, in practical vehicle driving this mode is also used so frequently. If the rate of change of speed is negative then it is called deceleration. In this mode the torque becomes negative, so controller converts mechanical power to electrical energy i.e. controller starts work in regenerative mode. Converter configuration for regenerative mode of UCEV shown below-

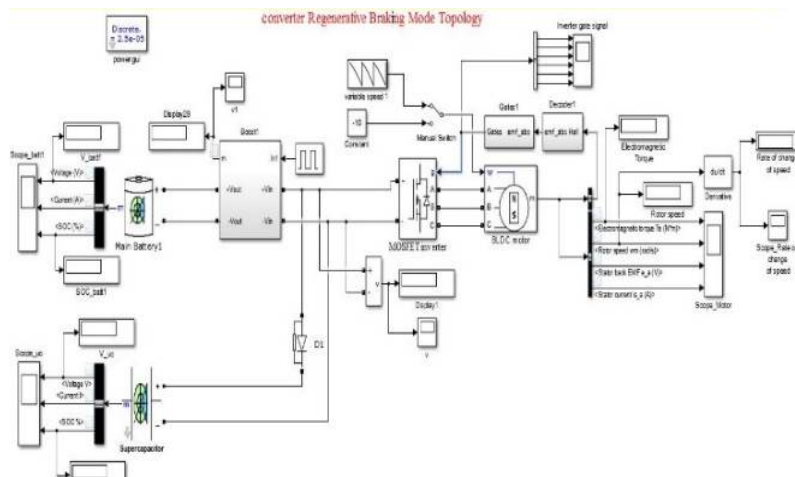

Fig. 14 Configuration for regenerative mode operation

The waveforms of battery, motor and inverter parameters for this regenerative mode operating mode are shown below-

Fig. 15(a) shows that the fluctuation in battery voltage is very small i.e. 0.04V in 340V, so it can be neglected. Similarly, closed waveform of battery voltage shows that ripples at the edge of voltage waveform is order of 0.005V, it can also be neglected in comparison of 340V.

# International Journal of Innovative Research in Science, Engineering and Technology

(An ISO 3297: 2007 Certified Organization)

Vol. 5, Issue 12, December 2016

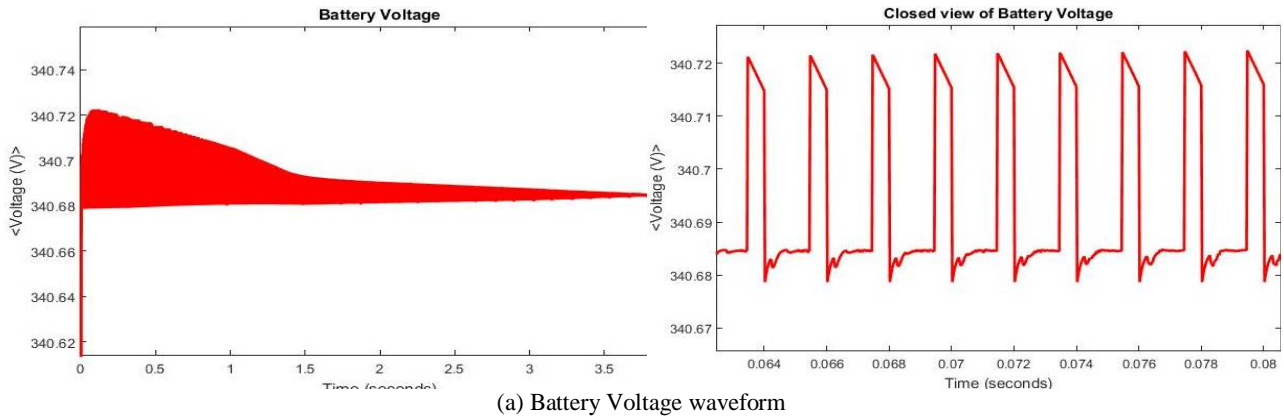

(a) Battery Voltage waveform

Similarly in fig. 15(b) the ripples presented in battery current is order of 0.4A, which can be observed in closed view of battery current waveform.

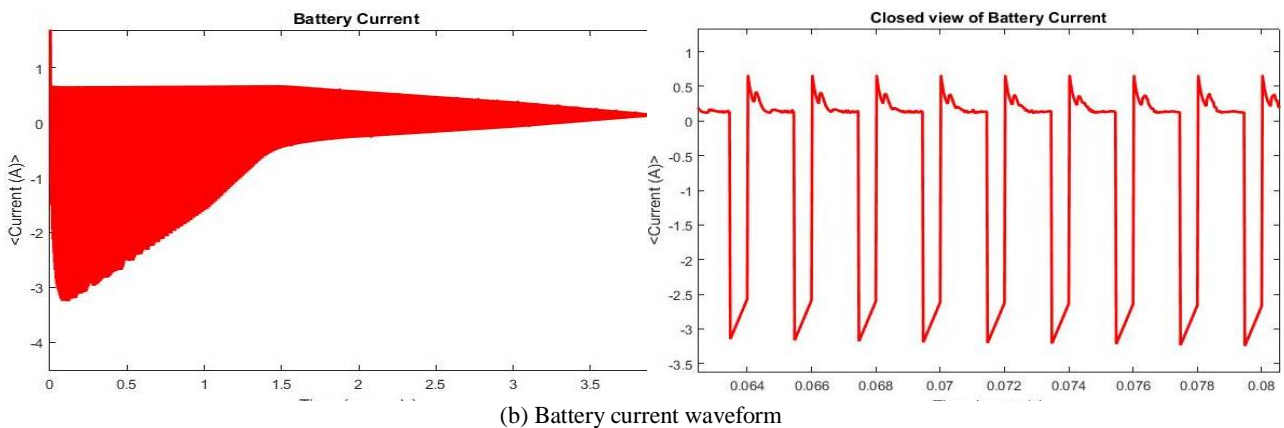

(b) Battery current waveform

It is clearly observed in fig. 15(c) that transient effect is more on UC voltage as compared to battery voltage shown in fig. 15(a).

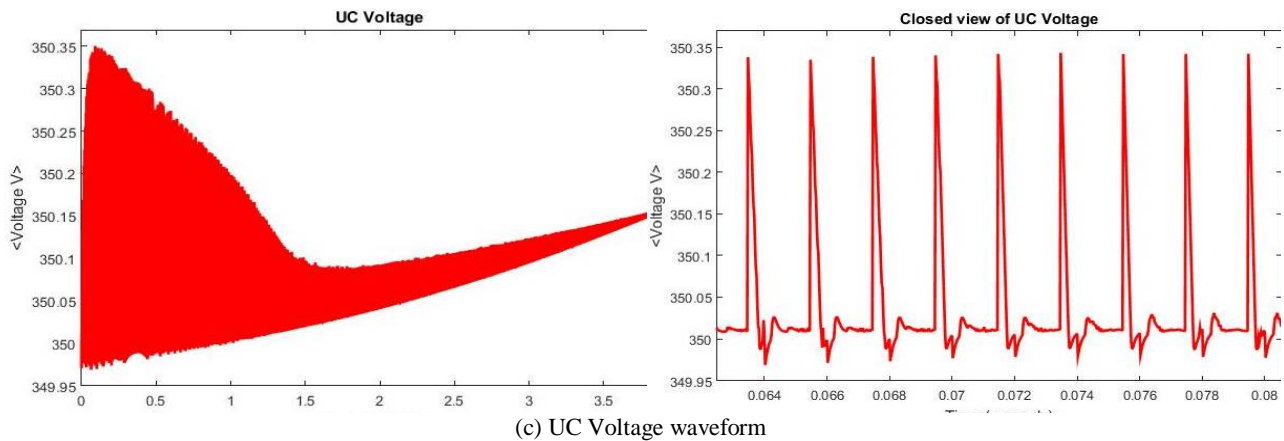

(c) UC Voltage waveform

Similarly fig. 15(d) shows that transient effect is more on UC current as compared to battery current waveform shown in fig. 15(b).

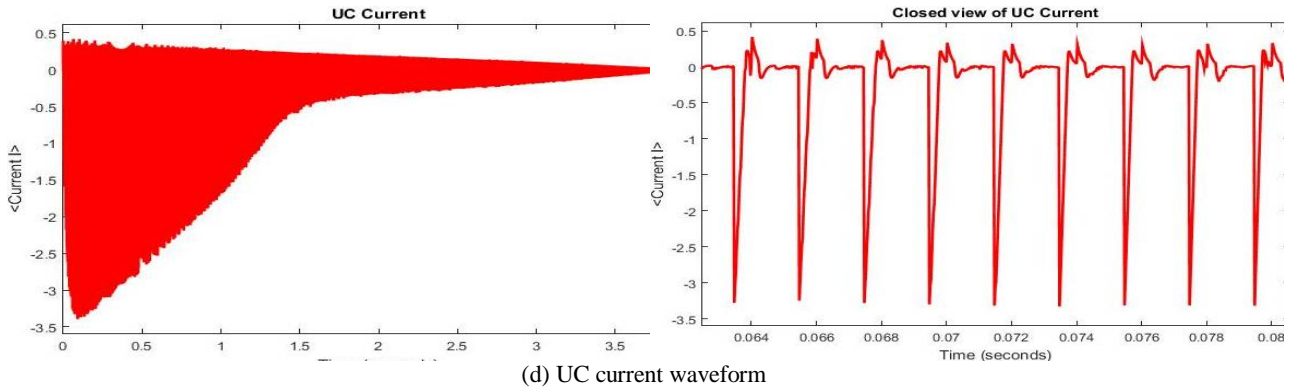

The regenerative voltage passes through boost circuit so that UC+Battery can be utilize more power. The waveform of boost voltage is shown below in fig. 15(e).

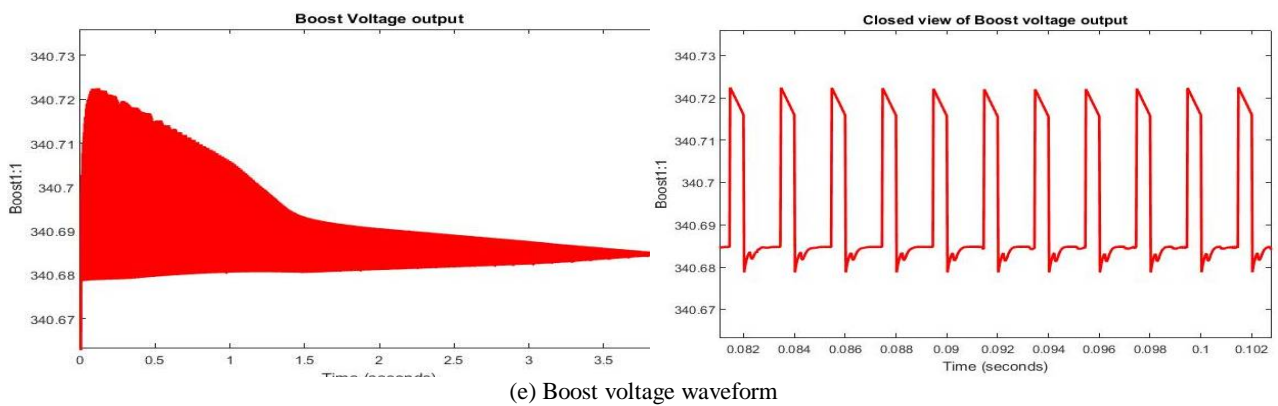

Fig. 15(f) shows that as speed decreases emf waveform magnitude decreases and frequency too. It support is statement for fig. 13(e).

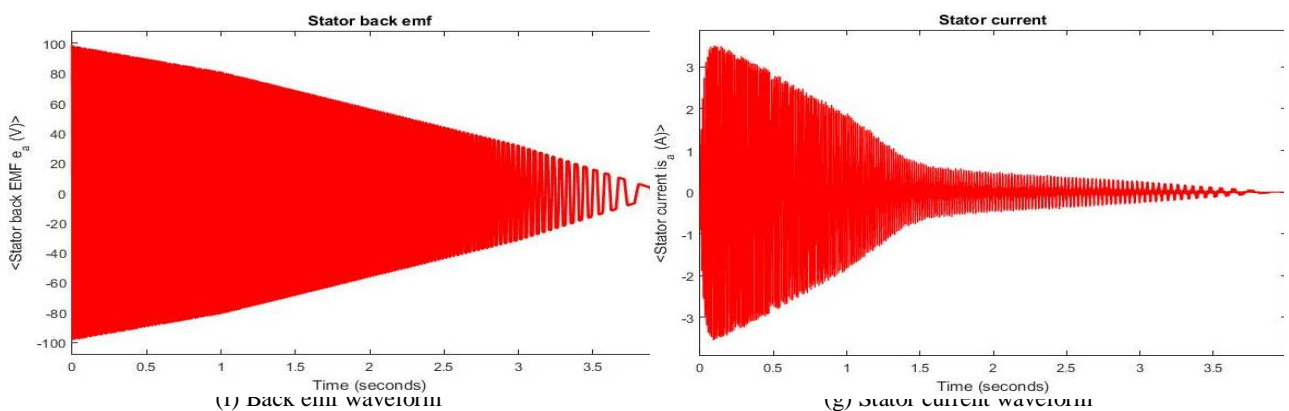

Fig 15(g) and fig. 15(h) shows that at 1.5sec the speed became too slow that is the reason of drop in torque and it also reflected in stator current waveform. Fig. 15(h) shows inverter gate signal for regenerative mode operation.

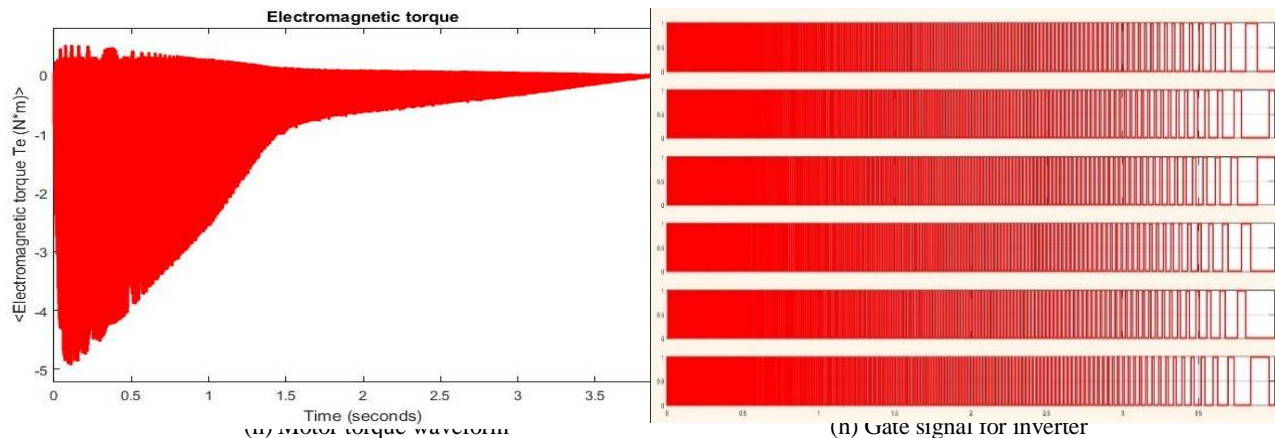

Fig. 15 Waveforms for regenerative mode operation

## V. RESULT DISCUSSION AND CONCLUSION

From above results some key points should be discussed like-

- i. Simply to obtain more torque, choose motor with more no. of pole pair.
- ii. Fig. 8(f), 10(f), 13(h) and 15(h) clearly shows that gate signal fed to inverter varies with emf of coil a, coil b and coil c.
- iii. Switching Controller automatically change the converter configuration based on rate of change of speed.
- iv. Ripples are absorbed by UC while accelerating and regenerative mode. In constant low speed and constant high speed operation negligible ripples present so no need to connect UC.
- v. After comparing the voltage and current waveform of battery with ultracapacitor in each cases the study showed that how efficiently ultracapacitor absorb the transient and protect the batteries from overheating and other factors which causes short life, damaging plates of battery, poor performance.
- vi. The analysis of performance of motor under all cases showed satisfactory results.

## REFERENCES

- [1] Iqbal Husain, "Electric and Hybrid Vehicles Design Fundamentals", CRC Press, Boca Raton London New York Washington, D.C., ISBN 0-203-00939-8, 2003.
- [2] Mohan N., Underland T. M., Robbins W. P., "Power Electronics converters, applications and design" second edition, John wiley & sons inc.
- [3] Jian Cao, Ali Emadi, "A New Battery/UltraCapacitor Hybrid Energy Storage System for Electric, Hybrid, and Plug-In Hybrid Electric Vehicles", *IEEE Transactions on Power Electronics*, Vol. 27, No. 1, January 2012.
- [4] S. M. Lukic, J. Cao, R. C. Bansal, F. Rodriguez, and A. Emadi, "Energy storage systems for automotive applications," *IEEE Trans. Ind. Electron.*, vol. 55, no. 6, pp. 2258–2267, Jun. 2008.
- [5] S. M. Lukic, S. G. Wirasingha, F. Rodriguez, J. Cao, and A. Emadi, "Power management of an ultra-capacitor/battery hybrid energy storage system in an HEV," in *Proc. IEEE Veh. Power Propulsion Conf.*, Windsor, U.K., pp. 1–6, September 2006.
- [6] Junyi Shen, AlirezaKhaligh, "A Supervisory Energy Management Control Strategy in a Battery/Ultracapacitor Hybrid Energy Storage System", *IEEE Transactions on Transportation Electrification*, Vol. 1, No. 3, October 2015.
- [7] Zahra Amjadi, S. S. Williamson, "Digital Control of a Bidirectional DC/DC Switched Capacitor Converter for Hybrid Electric Vehicle Energy Storage System Applications", *IEEE Transactions on Smart Grid*, Vol. 5, No. 1, January 2014.
- [8] F. Akar, Y. Tavlasoglu, E. Ugur, B. Vural, I. Aksoy, "A Bidirectional Non-Isolated Multi-Input DC-DC Converter for Hybrid Energy Storage Systems in Electrical Vehicles", *IEEE Transactions on Vehicular Technology*, DOI 10.1109, 2015.
- [9] YoungkwanKo, Jeeho Lee, Hyeoncheol Lee, "A Supervisory Control Algorithm for a Series Hybrid Vehicle With Multiple Energy Sources", *IEEE Transactions on Vehicular Technology*, Vol. 5, No. 1, January 2014.
- [10] L. Gao, R. A. Dougal, and S. Liu, "Power enhancement of an actively controlled battery/ultracapacitor hybrid," *IEEE Trans. Power Electron.*, vol. 20, no. 1, pp. 236-243, January 2005.
- [11] M. Ortuzar, J. Moreno, and J. Dixon, "Ultracapacitor-based auxiliary energy system for an electric vehicle: Implementation and evaluation," *IEEE Trans. Ind. Electron.*, vol. 54, no. 4, pp. 2147-2156, August 2007.
- [12] W. Lhomme, P. Delarue, P. Barrade, A. Bouscayrol, and A. Rufer, "Design and control of a supercapacitor storage system for traction applications," in *Proc. Conf. Rec. Ind. Appl. Conf.*, pp. 2013-2020, October 2005.



## International Journal of Innovative Research in Science, Engineering and Technology

(An ISO 3297: 2007 Certified Organization)

Vol. 5, Issue 12, December 2016

- [13] A. Di Napoli, F. Crescimbin, F. GuiliCapponi, and L. Solero, "Control strategy for multiple input dc-dc power converters devoted to hybrid vehicle propulsion systems," in *Proc. IEEE Int. Symp. Ind. Electron.*, pp. 1036-1041, May 2002.
- [14] A. Napoli, F. Crescimbin, S. Rodo, and L. Solero, "Multiple input dc-dc power converter for fuel-cell powered hybrid vehicles," in *Proc. IEEE 33<sup>rd</sup> Annu. Power Electron. Spec. Conf.*, pp. 1685-1690, April 2002.

### BIOGRAPHY



**S. R. Somanshu** received M. Tech. from Department of Electrical Engineering, Kamla Nehru Institute of Technology Sultanpur, India in 2016, with specialization in Power Electronics and Drives. His research interests include electric vehicle, hybrid energy storage system for electric vehicle, electric vehicle with ultracapacitor, control algorithm, electric vehicle system optimization & control, voltage stability analysis and ANN application to control system problems. He is a Fellow of

IJEST, Fellow of IJERT, Fellow of Researchgate and student member of IEEE.



**Dr. S.K. Sinha** is a Professor in the Department of Electrical Engineering, Kamla Nehru Institute of Technology Sultanpur, India. He has more than 35 years of experience in teaching and research. His current area of research includes Fuzzy logic controller, Neural Networks, and Non-traditional Optimization and Simulation. He has published more than twenty papers in referred international

journals and more than thirty research articles in national and international conferences. He is member of ISTE, Researchgate, and IEEE.