

Modeling and Dynamic Analysis of Gear Box Casing Using Finite Element Analysis

¹ G Raghavendra Setty, ² Dr. Irfan A G, ³ Dayananda Totar, ⁴ Santhosh Naik

¹ M. Tech Student, Dept. of Mechanical Engineering, Akshaya Institute of Technology, Tumakuru, Karnataka, India

² Professor & Head, Dept. of Mechanical Engineering, Akshaya Institute of Technology, Tumakuru, Karnataka, India

³ Asst. General Manager, Dept. of Central Maintenance, JSW Steel Ltd, Vijayanagar Works, Bellary, Karnataka, India

⁴ Jr. Manager, Dept. of Central Maintenance, JSW Steel Ltd, Vijayanagar Works, Bellary, Karnataka, India

ABSTRACT: The main objective of this research work is to find the natural frequency and mode shapes of industrial gearbox casing. Industrial gearbox casing subjected to vibration induced by the harmonic excitation, meshing excitation, load fluctuation, varying speed and torque conditions. Noise and vibration are the reasons for transmission failure. So it is required to find the natural frequency for the accurate prediction of casing life and prevent it from resonance problem.

KEYWORDS: Gearbox casing, Modeling, Natural frequency, Finite element analysis, Mode shapes, FFT Analyzer.

I. INTRODUCTION

Gears are used to increase or decrease input speed. These gears are enclosed in a rigid closed housing called casing. The function of gearbox casing is to protect and provide a platform for gear transmission. The casing supports the shaft, hold the lubricant inside and protect the gears from dust and moisture from outside environment. Also it provides necessary cooling surface to dissipate the heat generated during the operation. The strength of the gearbox casing is an important parameter to be taken into account while designing the gearbox. The vibration analysis of gearbox casing is done using accelerometer along with a device called Fast Fourier Transform (FFT) analyzer. The main reason for heavy vibration is the resonance caused by the lower order frequency of transmission gearbox body.

To solve the fatigue failure caused by resonance, it is essential to carryout dynamic analysis and redesigning the existing gearbox casing. The gearbox casing is made using Solid Edge V 19.0 and Nastran (NX8) softwares and analysis is done in Ansys Workbench R 15.0. The optimization is based on the Ansys results, which can be used to enhance the efficiency of the gearbox design process.

PHYSICAL SIGNIFICANCE OF VIBRATION

- Frequency-what is vibrating?
(Frequency is the source of vibration)
- Amplitude-How much it is vibrating?
(Amplitude is the severity/size of the problem measured)
- Phase-How it is vibrating?
(Phase is the cause of the vibration and how is the member vibrating)

II. PROBLEM DEFINITION

A very high vibration is observed in the Gear box in Bar Rod Mill (BRM) of JSW Steel Limited, Bellary at 1000-1100 cpm the velocity is 10.3 mm/sec. It was observed from vibration analysis spectrum (FFT analyzer) the dominant frequency was 1st gear mesh frequency and results of analysis shows that the gearbox casing was operating dangerously close to

International Journal of Innovative Research in Science, Engineering and Technology

(An ISO 3297: 2007 Certified Organization)

Vol. 5, Issue 6, June 2016

resonance. So dynamic analysis was taken up on the gear box to identify the causes of high vibration. It was found that the natural frequency of the gear box casing was close to the 1st gear meshing frequency. In order to eliminate this problem the gear box casing natural frequency/frequencies should be shifted away from the operating gear meshing frequency range by suitable modifications. Various trial runs were done in the computer system for the same and the most suitable and optimal solution is recommended.

III. LITERATURE REVIEW

- [1] Vijaykumar, Shivaraju, et al. have studied about the vibration analysis of gear-box using FEA. An ANSYS Software is used to find out the natural frequency and harmonic frequency of gear-box casing resulting into the determination of range of frequencies to prevent resonance.
- [2] Fujin Y Yongxiang, Daowen Sn, et al have studied to reduce the noise and vibration of automobile transmission system by the structural optimization for better performance. Modal analysis of gearbox was formulated in 3-D software like Pro/E together with FEM.
- [3] Ashwani Kumar, Himanshu Jaiswal et al. the authors have investigated the problem of loose transmission housing for 2 and 3 connecting bolts unconstraint based condition. The paper presents the dynamic vibration monitoring of truck transmission gearbox casing using FEA numerical simulation method. The fall in natural frequency from zero displacement constraint based condition to 2 and 3 bolts loose transmission condition. The loose condition of casing leads to failure condition.
- [4] V. B. Maner, M.M. Mirza, et, al. authors have basically focused on the design optimization of gear- box foot casing. The author has done design optimization of gear-box foot casing at Top Gear Transmission Industry situated at Satara, India. The author has generated the 3D model in PRO-E software; static analysis is done on ANSYS software. The design optimization is based on ANSYS results. The main focus is to optimize the foot casing and to find out effective and efficient design of gear-box with respect to both cost and durability.

IV. METHODOLOGY

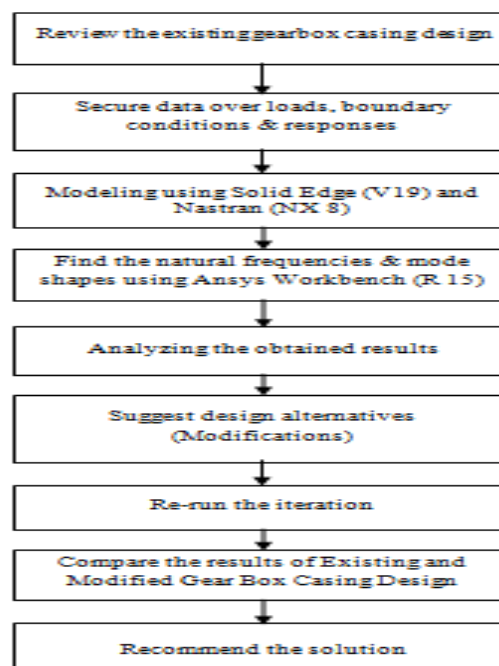

International Journal of Innovative Research in Science, Engineering and Technology

(An ISO 3297: 2007 Certified Organization)

Vol. 5, Issue 6, June 2016

V. 3D CAD MODEL OF GEAR BOX CASING

Solid Edge (V19) and Nastran (NX8) softwares are used for designing the gear box casing. The designed casing consisting of 14 holes at the both side of base used for constraining on ground. Fig 1 shows the 3D model of casing. The .iges file of casing is imported in Ansys 15.0 FEA based software used for free vibration analysis. Fig 2 shows the meshed model of casing. The present study provides the strong base for optimizing the resonance problem of a casing by finding the mode shapes and natural frequencies of existing and modified casing. Obtained first 10 natural frequencies and mode shapes of gearbox casing were considered.

VI. MATERIAL PROPERTIES AND BOUNDARY CONDITIONS

Gear box casing base is constrained on ground using connecting bolts. There are two types of predefined boundary conditions are available in Ansys for modal and free vibration analysis. These are free-free and fixed-fixed boundary conditions. In free-free boundary conditions all degrees of freedom are unconstrained. Fixed-fixed boundary condition is suitable for the casing analysis since it is constraint on ground by bolts. To provide the fixed-fixed boundary condition we have fixed the base part of the casing in software environment.

Gray Cast Iron FG 200 is used as casing material and mechanical properties of materials used for the dynamic analysis are elastic modulus (1.4e+005 MPa), poissons ratio (0.26) and material density (7200 kg/m³). In actual condition casing is tightly fixed on the ground using connecting bolts. Fixed-fixed constraint boundary condition is suitable for the gearbox casing analysis; it is constraint the motion of holes positions.

VII. DYNAMIC ANALYSIS OF EXISTING GEARBOX CASING

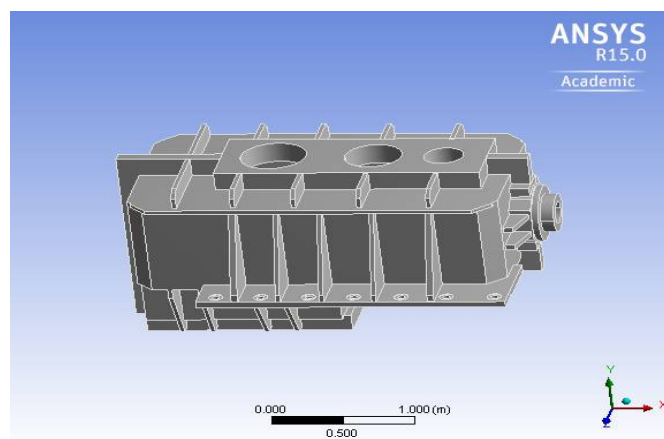

3D model of Gear Box Casing (Existing)

International Journal of Innovative Research in Science, Engineering and Technology

(An ISO 3297: 2007 Certified Organization)

Vol. 5, Issue 6, June 2016

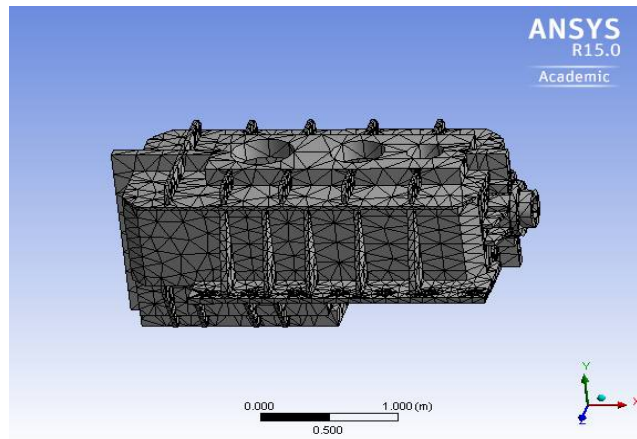

Meshed model of Gear Box Casing (Existing)

Mode No.	Natural Frequency in Hz
1	169.41
2	187.74
3	214.43
4	281.49
5	281.93
6	305.91
7	330.02
8	373.57
9	405.49
10	429.61

International Journal of Innovative Research in Science, Engineering and Technology

(An ISO 3297: 2007 Certified Organization)

Vol. 5, Issue 6, June 2016

1st Frequency mode range at 169.41Hz

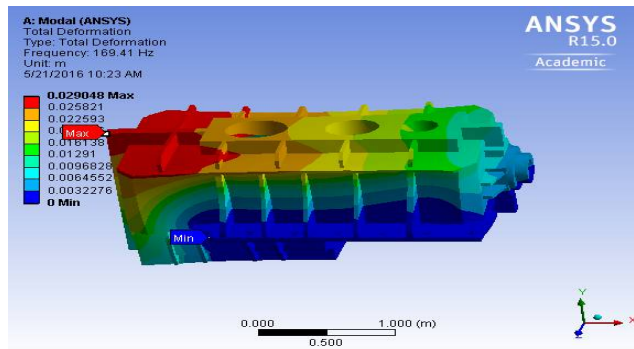

2nd Frequency mode range at 187.74 Hz

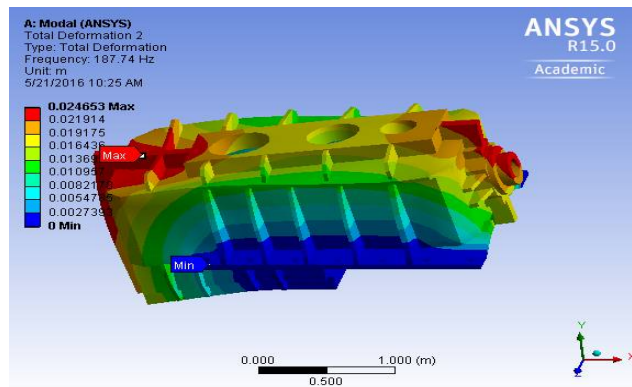

3rd Frequency mode range at 214.43 Hz

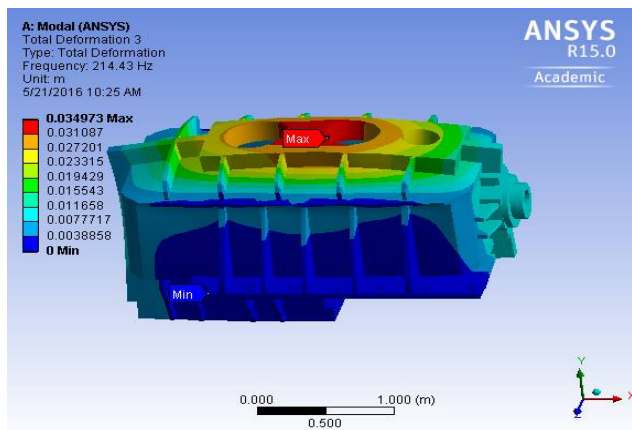

International Journal of Innovative Research in Science, Engineering and Technology

(An ISO 3297: 2007 Certified Organization)

Vol. 5, Issue 6, June 2016

4th Frequency mode range at 281.49 Hz

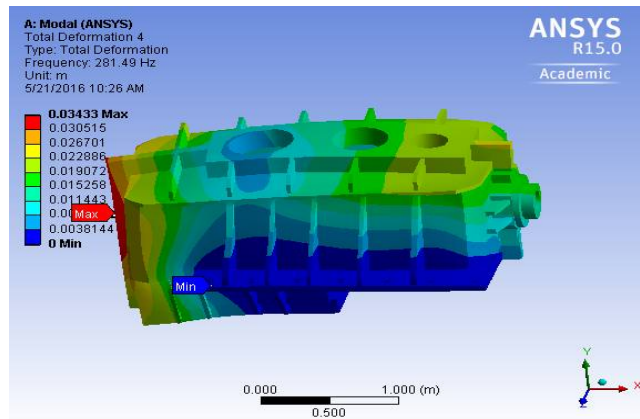

5th Frequency mode range at 281.93 Hz

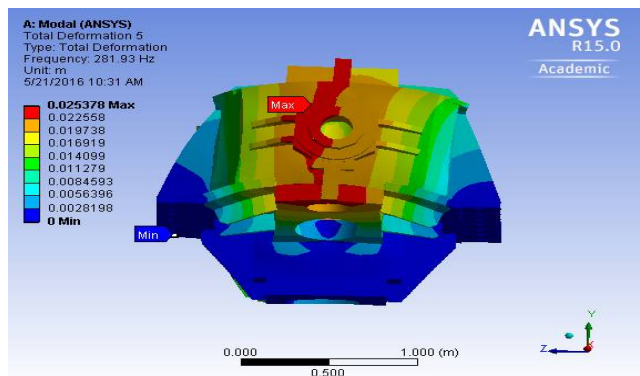

6th Frequency mode range at 305.91Hz

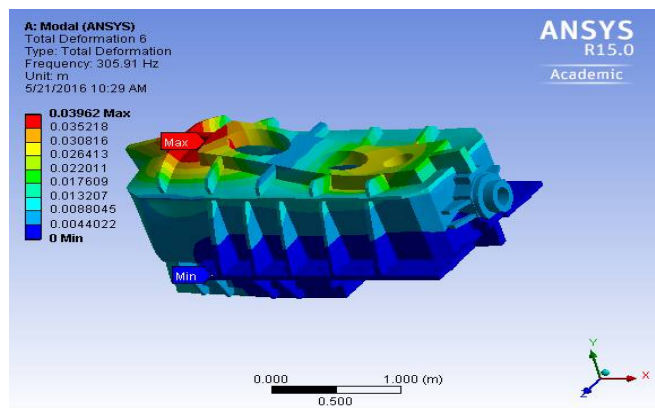

International Journal of Innovative Research in Science, Engineering and Technology

(An ISO 3297: 2007 Certified Organization)

Vol. 5, Issue 6, June 2016

7th Frequency mode range at 330.02 Hz

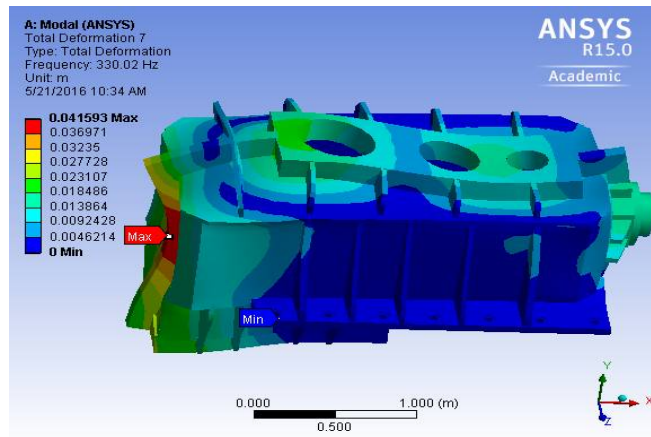

8th Frequency mode range at 373.57 Hz

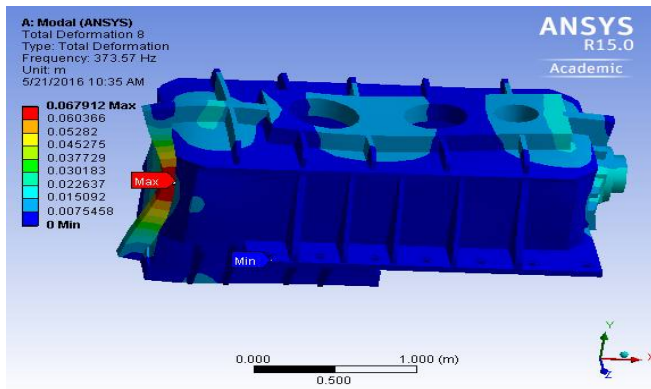

9th Frequency mode range at 405.49 Hz

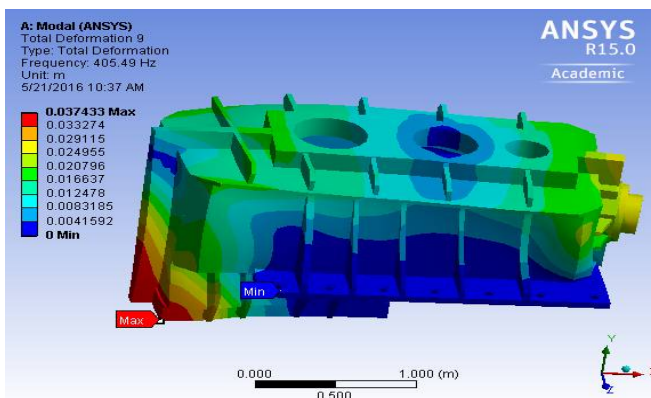

International Journal of Innovative Research in Science, Engineering and Technology

(An ISO 3297: 2007 Certified Organization)

Vol. 5, Issue 6, June 2016

10th Frequency mode range at 429.61Hz

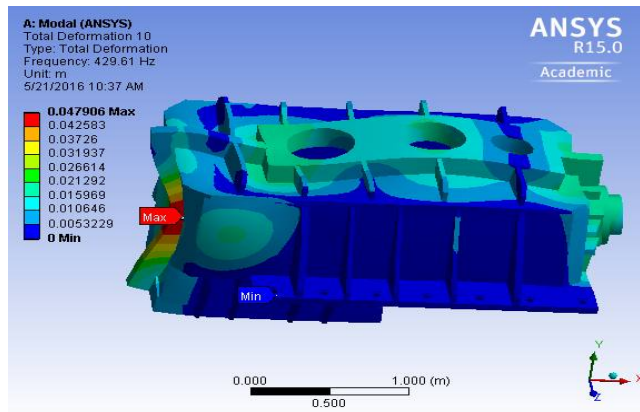

VIII. DYNAMIC ANALYSIS OF MODIFIED GEARBOX CASING

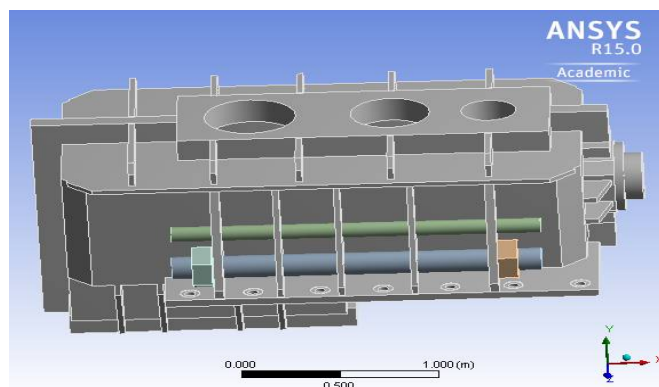

3D model of Gear Box Casing (Modified)

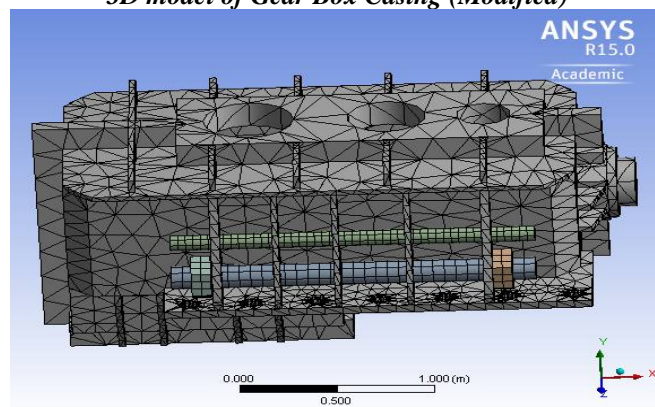

Meshed model of Gear Box Casing (Modified)

International Journal of Innovative Research in Science, Engineering and Technology

(An ISO 3297: 2007 Certified Organization)

Vol. 5, Issue 6, June 2016

Mode No.	Natural Frequency in Hz
1	209.05
2	223.74
3	263.34
4	314.71
5	361.39
6	395.41
7	471.47
8	512.61
9	563.66
10	583.72

1st Frequency mode range at 209.05 Hz

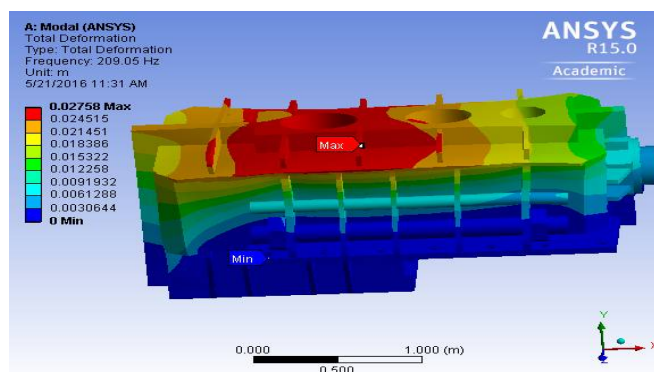

International Journal of Innovative Research in Science, Engineering and Technology

(An ISO 3297: 2007 Certified Organization)

Vol. 5, Issue 6, June 2016

2nd Frequency mode range at 223.74 Hz

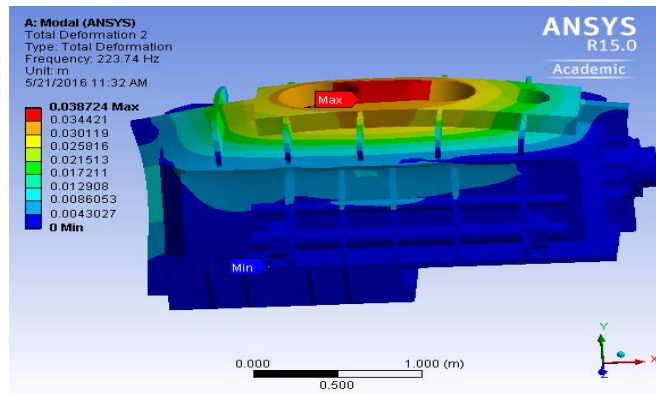

3rd Frequency mode range at 263.34 Hz

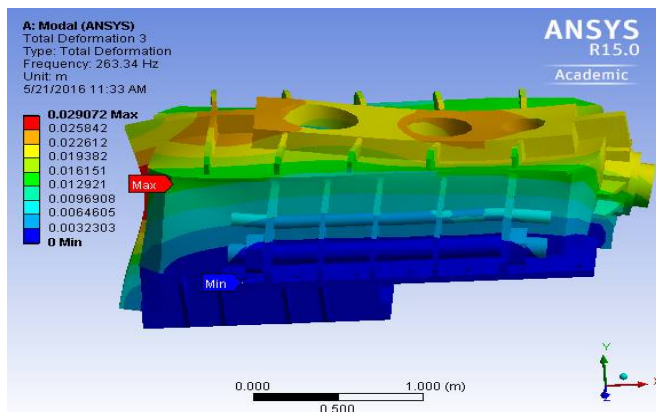

4th Frequency mode range at 314.71 Hz

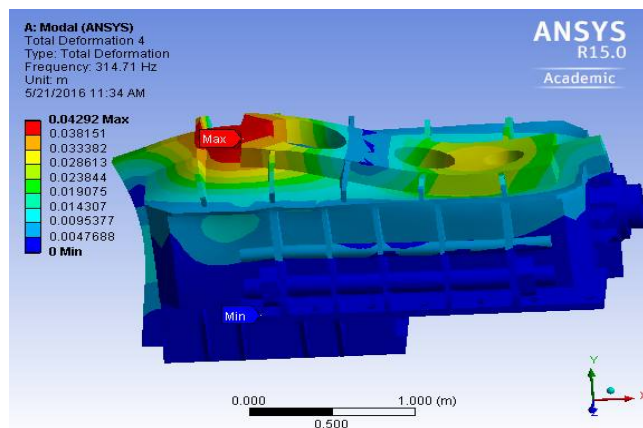

International Journal of Innovative Research in Science, Engineering and Technology

(An ISO 3297: 2007 Certified Organization)

Vol. 5, Issue 6, June 2016

5th Frequency mode range at 361.39 Hz

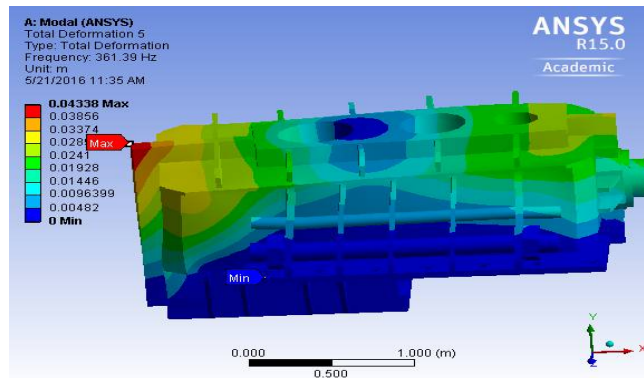

6th Frequency mode range at 395.41 Hz

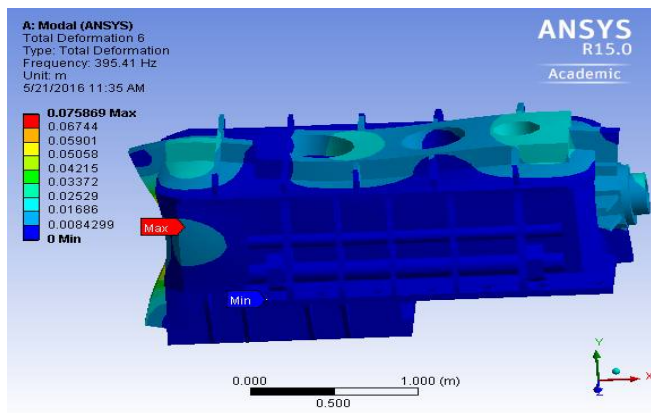

7th Frequency mode range at 471.47 Hz

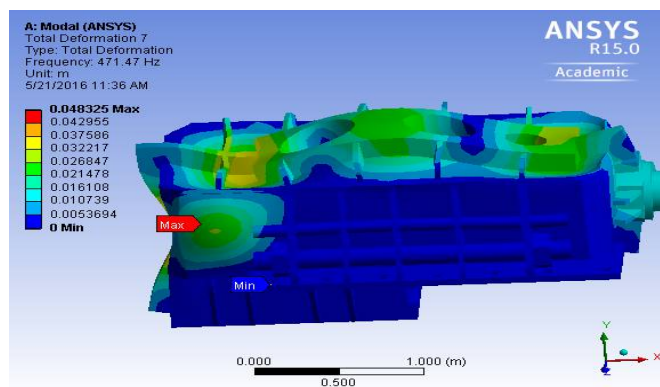

International Journal of Innovative Research in Science, Engineering and Technology

(An ISO 3297: 2007 Certified Organization)

Vol. 5, Issue 6, June 2016

8th Frequency mode range at 512.61 Hz

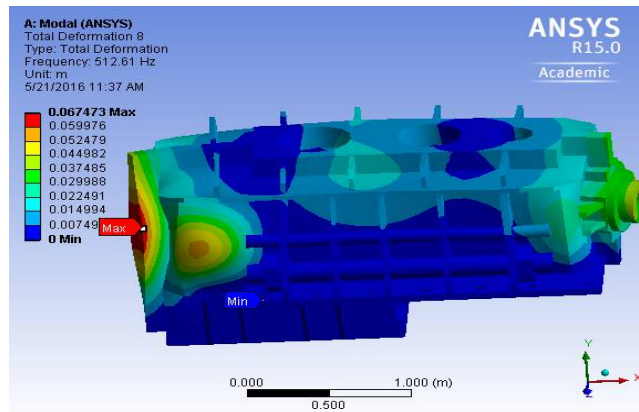

9th Frequency mode range at 563.66 Hz

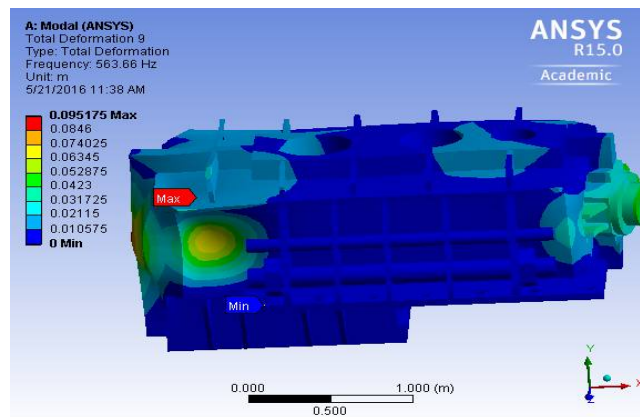

10th Frequency mode range at 583.72 Hz

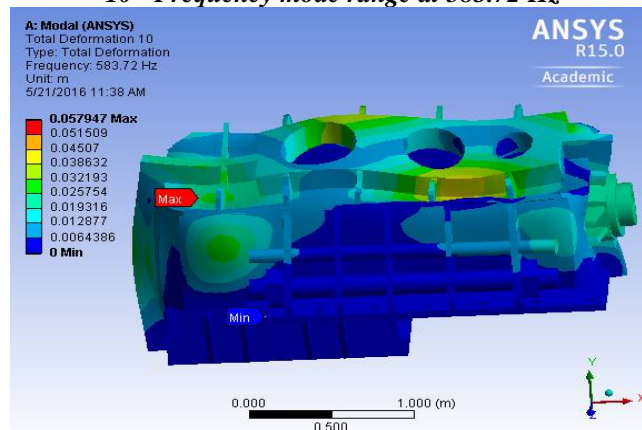

International Journal of Innovative Research in Science, Engineering and Technology

(An ISO 3297: 2007 Certified Organization)

Vol. 5, Issue 6, June 2016

IX. CONCLUSION

The following solution is recommended, after the detailed dynamic analysis conducted on the gear box casing. Gearbox casing was operating dangerously close to resonance, so dynamic analysis was carried to shift the natural frequencies of the gear box casing.

Different modification was tried and the best feasible modification is suggested to shift the natural frequencies of the gearbox casing. The gearbox casing natural frequency 281.93 Hz is shifted to 361.39 Hz by giving external stiffness.

Modification Details as follows

- [1] 2 rods of diameter 150 mm & length 1875 mm with 2 nuts of diameter 150 mm and thickness of the each nut is 100 mm fitted in two sides of the casing (attached near to the base)
- [2] 2 rods of diameter 100 mm & length 1875mm welded in two sides of the casing (attached near to the top)

As a result of this modification the stiffness of the gear box casing is increased and the natural frequency is shifted away from the resonance band.

X. ACKNOWLEDGEMENT

The author thankful to the Dayananda Totar (AGM) and Santhosh Naik (Jr.Manager) of Central Maintenance Department, Anjaneyulu C R and Balaji Prasanna B of HR Department, JSW Steel Limited, Vijayanagar Works, Bellary, Karnataka for providing necessary facilities and timely support for the successful completion of this research work. and Dr.Irfan A G, Guide, Professor & Head of Department of Mechanical Engineering, Akshaya Institute of Technology, Tumakuru, Karnataka for their advice and guidance in finishing this paper.

REFERENCES

- [1] Vijaykumar, Shivaraju, Srikanth, Vibration Analysis for Gear-Box Casing Using Finite Element Analysis. The International Journal of Engineering And Science (IJES). Volume- 3, Issue-2, (2014) ISSN (e):2319-1813 ISSN (p): 2319-1805.
- [2] Fujin Y Yongxiang, Daowen Sn, Wenquan Shen, Weiqiang Xia, Analysis for the Dynamic Characteristic of the Automobile Transmission Gearbox. Research Journal of Applied Sciences, Engineering and Technology (RJASET). 5(4): 1449-1453, 2013 ISSN:2040-7459, e-ISSN:2040-7467, Maxwell Scientific Organization, 2013.
- [3] Ashwani Kumar, Himanshu Joshi, Pravin P Patil: Vibration Based Failure Analysis of Heavy Vehicle Truck Transmission Gearbox Casing Using FEA. *Composite Materials, Proc. Of Intl. Conf. on Mechanical Engineering*, pp 251-259, ISBN: 9789-3510-72713 (2014)
- [4] V. B. Maner, M.M. Mirza, Shrikant Pawar, Design Analysis And Optimization For Foot Casing Of Gear-Box. Proceedings of 3rd IRF International Conference, 10th May-2014, Goa, India, ISBN: 978-93-84209-15-5.
- [5] SOLIDEDGE Version 19.0 (2006)
- [6] ANSYS R15.0 Academic, Dynamic & Structural Analysis guide (2016)