

Review on Leaf Spring Type Suspension System

Prasanna D. Dhumal¹, Mayur S. Jadhav², Rushabh S. Tawar³, Sameer A. Agrawal⁴

U.G. Student, Department of Mechanical Engineering, Smt. Kashibai Navale College of Engineering,
Maharashtra, India^{1,2,3}

Assistant Professor, Department of Mechanical Engineering, Smt. Kashibai Navale College of Engineering,
Maharashtra, India⁴

ABSTRACT: Today suspension system is an integral part of the automotive functioning. This review observes the key areas of designing the suspension system from the aspect of durability, failure analysis and some novel methodology adopted for quick and effective design. Low cost and high reliability of the leaf springs makes them suitable for commercial vehicles even today. Fatigue analysis of the springs to the increased load and its failure at certain cycles is an assessment of the current design process. Along with vertical static loads, a number of loads are analysed and taken into consideration.

KEYWORDS: Leaf Spring, Fatigue, Suspension system.

I. INTRODUCTION

With the advent in modern technology a wide variety of suspension systems are now used in vehicles, although majority of heavy vehicles utilize leaf springs as their suspension sub-system due to a wide merit base such as low cost, easy maintenance and high load carrying capabilities. Leaf springs are an assembly of various components like leaves stacked together, center bolt, U-bolt. Main leaf has eyes at both ends for the ease of mounting. There are various types of eyes such as Berlin, Uprturned, Downturned, Military-Wrapper type etc. which are used based upon the loads it encounters and manufacturing feasibility. Vehicle suspension system is classified into three types i.e. passive, semi-active and active suspensions, which depends on working feature to enhance vehicle safety, ride comfort and overall performance. Springs absorb the static and dynamic loads within yield point thus providing proper handling and comfort. The energy is stored as strain energy and hence the strain energy of material becomes an important aspect in the design of springs. Nowadays CAE tools have found a broad base of application in automobile industries. Their use has even made the reduction of costs in product development while developing the safety, comfort, and durability of vehicles. The predictive features of these tools have made verification of design very simple and have improved reliability on digital devices using simulation instead of practical prototype testing. Dampers along with the basic suspension system are also a very critical part of design and need to be incorporated. The paper also shows that while designing the suspension system fatigue life and loading must be exercised as fracture analysis is the backbone of designing.

II. BACKGROUND

The suspension system smoothes out the ride and keeps the car in control. It enables the constant contact of the tire with the road so that a good stability to the vehicle and better ride handling is achieved. The suspension system enhances the comfort of passengers by reduction in the shocks due to complex forces acting on the axle. Commercial and heavy duty vehicles perform satisfactorily with leaf springs as the suspension system. The elasticity and interleaf friction aid in absorbing the shocks on road. The leaf springs are curved in profile (these are often called elliptical springs); the curvature helps the spring to absorb impact. The frequency at which the leaf spring responds is different

for types of vehicles and has a range of values.

III. LITERATURE REVIEW

M. Malikoutsakis et. al. ^[1]The paper is a brief optimized procedure for a commercial suspension system for high performance usually adopted by the vendors. The paper mainly focuses on leaf spring suspension subsystem for the front axle as shown in [Fig.1](#), and the whole design procedure is explained. It covers key areas of design such as problem statement, procedure, material selection right up to testing by professional drivers on a test track. Fatigue analysis was also carried out establishing the consequences of various materials on the fatigue life of the leaf springs. Loads encountered while straight driving and braking were found to be the most critical on which the situation was primarily based. A novel method called durability test was used to have an overview of the failure of the front arm. This was to ensure to have pre-knowledge of when the arm fails as its failure can cause the driver to lose control of the vehicle. Miner's damage accumulation rule was used along with the S-N curves and a sensitivity factor to gain damage plateau. Although the paper focuses mostly on a mono leaf spring for a huge load a multi-leaf spring would be more desirable.

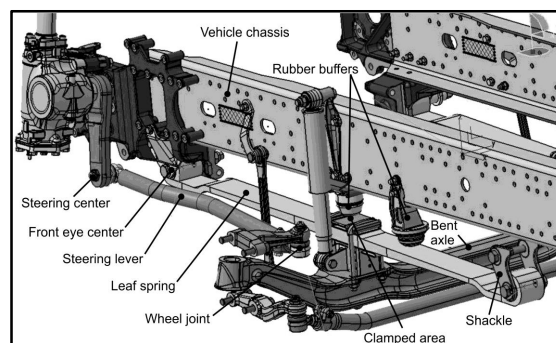

Fig.1: Front axle solid suspension in conjunction with steering system

Gerhard Fischer et. al. ^[2] This paper mainly focuses the various loads that are encountered by the leaf springs during their life-cycles like vertical, lateral, longitudinal loads and the loads during acceleration and braking as shown in [Fig.2](#). Fatigue testing of leaf springs generally involves sinusoidal loading and uniaxial loading. The loads encountered in practical applications are way beyond simple vertical loads. This paper describes the fulfilment of a setup that tests the spring under multi-axial loads, thus simulating real life loads for knowing fatigue life and also briefly shows the process that was carried and its results verified with the traditional method. The setup involved used of hydraulic actuators for loading and strain gauges for the instrumentation of the parameters of the test. The same setup is applied for testing other vehicles that involve different kinematic conditions and thus save the development time and cost. Apart from loading other factors of failure like ineffective shot peening, coating, tolerances are also recognized. In addition, various failures of the leaf spring are shown through diagrams. This procedure can be readily adapted to for the testing of leaf springs from a set of vendors and thus reducing the risks involved.

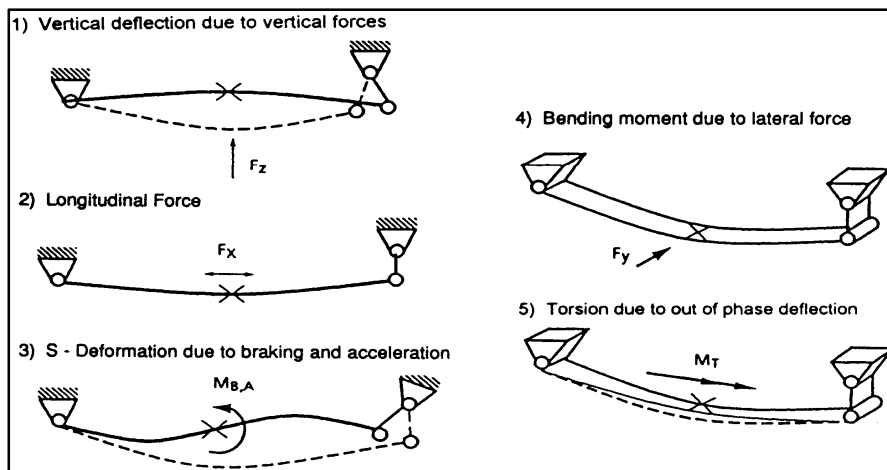

Fig.2: Loads on Leaf Spring

N. S. Mendhe et al.^[3] The literature observes the vehicle suspension system for study of static and fatigue characteristics of leaf spring, leaf spring optimization, leaf spring design for heavy axle loads etc. This paper includes the comparison of leaf spring performed by finite element method. In this several attempts to perform the optimization of the factors of two different grades of steels. According to the literature, the leaf springs are held in tension, compression, bending, torsion and shear; hence they are prone to fatigue failure. The primary load being vertical load, they are also subjected to F_s (side load), F_t (longitudinal load), T_t (twisting torque) and T_w (wind up torque) as shown in Fig.3. Failure at the eye end is evaluated in the paper for which the modeling of the spring is done in PRO-E and analyzed in ANSYS12.0V Workbench. Stiffness, deformation, stress, safety factor, area, moment of inertia, width, thickness, length of leaves and number of leaves are the most crucial factors while carrying out analysis. From all these factors stiffness and developed stress are the most influencing parameters. In this testing of the spring is carried out for optimization of a number of leaves.

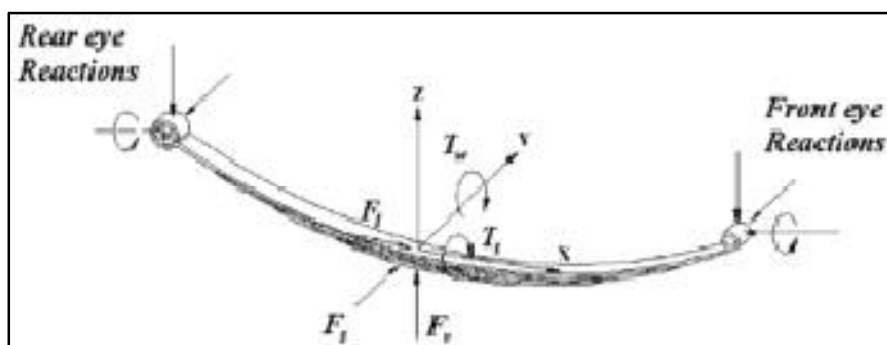

Fig.3: Forces acting at the axle seat of a leaf spring.

F_v : vertical load, F_s side load, F_t : longitudinal load, T_t : twisting torque, T_w : wind up torque.

Medha Santosh Jambhale et. al.^[4] This paper states the procedure to make semi-active suspension control system. The simulation model used is the VDYNA vehicle model duly verified with information used to produce a semi-active suspension with PID controller. In this type of suspension system, MR (Magneto-Rheological) damper is used and the control logic is verified with the use of software in loop (SIL) technique and further with component hardware in loop (cHIL) technique. The research of active/ semi-active suspension has applied needs and helps in achieving an optimum level of ride handling which helps us to infer the safety and comfort riding. In both techniques, there is use of road profile (digitally) which is analyzed in the situations of ride handling characteristics of the suspension. For SIL technique model, MR damper is used. To speed up the vehicle development process various tools are used. This is an

International Journal of Innovative Research in Science, Engineering and Technology

(An ISO 3297: 2007 Certified Organization)

Website: www.ijirset.com

Vol. 6, Issue 1, January 2017

effort to display the application of Component Hardware in Loop technique for the development of semi-active suspension. In a suspension design procedure damper optimization is one of the major tasks. To face the most cases, dampers properties are first taken from a known platform and also the vehicle properties. Based on this selection simulation is carried to derive a set of properties. The final selection of dampers is carefully done from vehicle level experiments. The drawback of the approach is to develop a damper which is highly nonlinear which urges to the development of semi-active suspension system. Further to this, the expected design control logic is necessary. The design, research, and verification of semi-active suspension control logic are explained in the paper.

Y.S. Kong et. al. ^[5] The analysis is of two types; one of which is a static analysis to find stress and strain while other is multi-body dynamics (MBD) analysis to analyze a range of factors that are costly and complicated to test for a leaf spring for a heavy-duty truck. Many times the design is concentrated on thickness and stiffness of leaf spring but the paper presented a more logical approach to spring design. Often leaf spring eyes are revolute joints which encounter bearing stress of high order which is often ignored. The author used various hard-points to make an MBD model and a CAD model for structural analysis. The paper has compared a few types of eyes that are used to design a leaf spring and all the forces that each type encounters. In addition to a linear analysis, the author also conducted a non-linear analysis for the phase of rubber touch to fully compress as rubber exhibits non-linear characteristics. A maximum load of that the spring encounters is when the truck encounters a pothole and can cause the leaf to enter the plastic state. Thus in the paper, the author optimizes the eye design for vertical, longitudinal and shear loads exploring a new failure possibility.

V.R.Baviskar et.al. ^[6] The leaf spring (master leaf) is subjected to static analysis with a provision of support which is provided at the center of the leaf. The paper consists of various ways to reduce stress concentration at the eye section and the other parts of the leaf spring by increasing the cross-section area which ultimately results in increased strength. It deals with the findings of fatigue life from stress approach model, since the main failure to which leaf springs are subjected is fatigue failure. The post literature review shows that the leaf springs are subjected to various forces and they are attached to the axle, which provides reaction forces. In this paper, for analysis purpose the leaf spring is modeled in CATIA VSR5 19 and to validate the safety of design, the analysis is done in ANSYS 14 software. It is concluded from the above-mentioned procedure whether the modeled leaf spring is satisfying the required condition or not.

A. Donoso et. al. ^[7] Buckling is a famous definition in structure mechanics that occurs in long elastic structures on the cost of compressive loads. After the compressive loads post certain critical limit, it is termed as the structure buckling, and after buckling, it becomes a deformed configuration. Such situations are a result of the elasticity in a nonlinear ordinary differential equation which is calculated integrals. There are two clamps instead of the rollers that constrain the horizontal displacement of the leaf springs at their external reams. Based on a previous model of an adjustable stiffness spring, with leaf springs working in bending, developed a new scheme when the leaf springs are working in post-buckling situations. The numerical results are from mathematical calculations also proposed to model the mechanical behaviour of leaf spring in excellent condition with that of obtained in the results. The new device is used where a negative slope in the displacement–force curve is required, like switches, where the system changes its position from two separate forms.

C.K. Clarke and G.E. Borowski ^[8] The paper consist of discussion about the evaluation of failure of rear leaf spring that occurs in sports utility vehicle while in an accident sequence. The presentation of this failure is expressed in the form of residual strength estimates and analysis of fracture surface. There are two possibilities pointed during an accident for failure: first during the initiation of the accident sequence the marks are observed in the roadway and also at the termination of sequence a rock strike is observed. During evaluation of leaf spring fracture, it is observed that half of the spring is cracked before the accident. It is evident due to rust and chemical contamination which is observed to the point where a failure occurs. This also subjected to secondary a crack which is observed at the plane. This shows that there is the presence of segregation and weakness in the leaf spring. The stress calculation gives the yielded residual-strength level which is observed before the cracking in the spring. This condition is expected during the travel over a

International Journal of Innovative Research in Science, Engineering and Technology

(An ISO 3297: 2007 Certified Organization)

Website: www.ijirset.com

Vol. 6, Issue 1, January 2017

rough road. Thus it is evident that the spring rupture takes place prior to the accident because of various reasons which are mentioned above and location of the rupture point placed at accident sequence, because of stresses which occur at that point. Thus, the fracture occurred is placed at the sequence of the accident.

Stylios Karditsas et. al. ^[9] This paper mainly focusses on the parabolic leaf spring. The idea discussed was the comparative trajectory of the steering knuckle for various deflections to the trajectory of leaf spring. As shown in the Fig.4, both trajectories should be as near as possible to avoid effects like bump steer. The validation is by FEM models to verify the stress distribution. It also compares the eye type and the eccentricity on the arm rate at various designed conditions although they do not have a significant effect on the stress encountered. The procedure for carrying out analysis presented a solid background for future FEM prototypes for different vehicles incorporating the same system for different loads. The paper crucially connects two sub-systems like steering and suspension and validates the design by Finite Element Model.

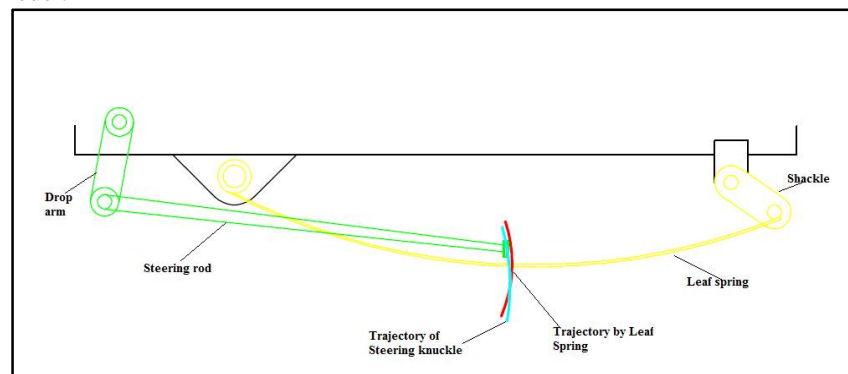

Fig.4: Trajectories of wheel travel for steering and suspension sub-systems.

Bruno Geoffroy Scuracchio et. al. ^[10] The main function of shot peening is to induce stresses at the part's surface, thus encouraging its fatigue life, which is recognized for several years. In automotive springs, the shot peening process of manufacturing is an important part of the production. In depth study of the process of shot peening is required. The study of stresses in fatigue tests on a series of samples that are subject to various peening. Among the studied processes, the use of 0.8 mm diameter steel shot which is followed by a secondary peening with 0.3 mm diameter steel shot that leads to best performance, regarding fatigue life. X-ray diffraction investigation shows that new assessment is comprised of compressive stress served at a depth of 0.02 mm below the surface, indirectly inspires fatigue crack. Stresses by shot peening in bigger depths have no consequences on the sample's fatigue life.

Dipendra Kumar Roy et. al. ^[11] The current situation deals with the mathematical analysis of deflection of cantilever beams for material properties with a vertical load suspended at the free end. In free end displacement, there is a fluctuation of stress, strain and the bending moment of the beam having fluctuating material properties with length obtained by the method of minimization of total potential energy. The numerical formulation is based on a variation principle using assumed mode method. The displacement functions are an arbitrary linear combination of functions, developed through equilibrium equation. The solution of the displacement problem is achieved using MATLAB simulation. It is observed due to displacements and the reductions of beam length are largely affected by variables in elasticity. The current situation is verified and results have been published. The inspiration of materials for various types distribution is shown for different types of loading.

Vinkel Arora et.al. ^[12] The literature had done a comparison of leaf springs made up of two different materials in order to validate the results. This work is done on leaf spring of front end of a commercial vehicle. The paper carries out design by using CAD software and analysis of leaf spring with considering the various design considerations and loading conditions. Since CAE tools are capable of controlling product cost and time, they are used in automobile industry. It results in improved safety, comfort, and durability of the vehicle. The accuracy of the CAE tools is increased

International Journal of Innovative Research in Science, Engineering and Technology

(An ISO 3297: 2007 Certified Organization)

Website: www.ijirset.com

Vol. 6, Issue 1, January 2017

to such a level that most of the correction is done with the help of computer simulation over prototype testing. Though CAE is preferred over conventional method still physical testing is done. Since CAE tools are not distinctive to show accurate variables are complex assemblies. Hence validation of the CAE results is important. The paper consist model of leaf spring is made up of material which is different than the widely used material, for which modeling is done in CATIA and analysis is performed using ANSYS. This is carried out under different load conditions of deflection and stresses. For validation, the results of experiments and CAE are compared.

Anirban C. Mitra et. al. ^[13] This paper describes a special application of mechatronic test systems. A test rig model as shown in [Fig.5](#), was developed to test a quarter of a car for its suspension. Ride and comfort is a big term that incorporates various factors like camber, toe, tire pressure, the stiffness of spring road conditions etc. It's very hard to test out all the conditions, but with the test rig that is developed by the author, many of the dynamics of the car can be evaluated for optimum ride and comfort. As the term ride and comfort is a variation, its range is established where the values should lie. The test rig is interfaced to a data acquisition system and thus all the values are recorded on a processor and the outputs are represented in the paper. The paper represents an independent suspension system, although the same is applied to test out leaf spring suspensions systems. The main thing the paper reflected was that through interfacing time and money can be saved for testing of the models. It's an alternative for FEM models or rather complimentary depending on the design conditions.

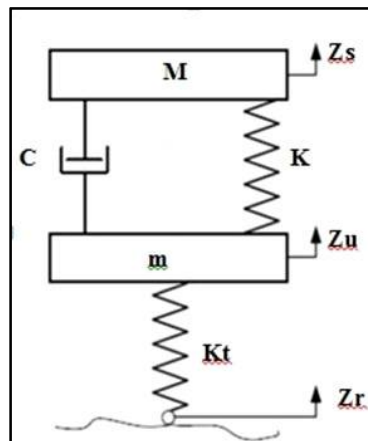

Fig.5: Physical quarter model

Basaran Ozmen et. al. ^[14] The paper aims to find out fatigue life under the increasing amplitude loading. It states that the fluctuating amplitude loading tests are exercised because none of the cumulative damage hypothesis can decide the fatigue life for loadings. Thus, these parameters are necessities to have real damage approximately with Gassner-lines, the rule of the spectrum distortion with the size L_s are added up and calculations are found from this value by using experimental results. The paper presents testing and simulation for longer life of leaf springs based on measured loads. This study displays a complete production process with the help and guidance of testing and simulation works to build a durability assessment analysis of leaf springs based on rapid fatigue life testing with the help of increased amplitude loading.

Priyanka Kothari, Amit Patel ^[15] the paper consists of a general study on design, analysis and fabrication of leaf spring. Leaf springs are used in the suspension system of commercial vehicles and they are the oldest component of the suspension system. The leaf spring type suspension system is used to reduce shocks and support the vertical load. The literature shows a growing interest in replacement of steel leaf spring with another material which is having much higher strength than steel and also it should be light in weight. Such kind of material also possesses very high fatigue resistance. The vehicle is significantly affected by its suspension system which accounts for ride comfort and stability of vehicle etc. The leaf springs are prone to a large number of fluctuating stress cycle which causes its failure by fatigue. A lot of research is done on leaf springs in order to increase its fatigue resistance. For literature, the most effective

International Journal of Innovative Research in Science, Engineering and Technology

(An ISO 3297: 2007 Certified Organization)

Website: www.ijirset.com

Vol. 6, Issue 1, January 2017

solution to this problem is a change of material of spring. The newly developed fiberglass material possesses all required characteristics when it is evaluated against the steel leaf spring. To prove that the author reviews few papers which are consist of the use of alternative materials and effects of this on the performance of leaf spring.

Ishwar Patil et. al. [16] Ride handling and comfort are very important features that inspire the vehicle characteristics. The suspension systems of the vehicle are dependent on these parameters. A semi-active damping system is an element in which the dissipation law can be modelled. The system is cost effective, has light weight and low energy consumption, and is used in passenger vehicles of the future. There is sensible control; the semi-active systems provide complete performance between active systems and passive systems. Various schemes of semi-active dampers are cited in the paper. The initial is the semi-active “on-off” system, in which hard and soft damping coefficients are applied depending on the product of body velocity and damper velocity. Time response analysis is checked out in Simulink and display of results for a better understanding of various semi-active control models for a vehicle is carried out.

IV. CONCLUSION

This study concludes various areas of leaf spring suspension design and analysis. It gives a scope that its design, durability, and fatigue can be studied in more depth. The fatigue life can be increased significantly by the change of materials, which calls for the use of composite leaf spring. The material change gives way to reduced weight which gives lesser stress values in overall consideration. There is a display of the analysis of every literature and all of them share the same view of studying this component in a very different approach. A number of softwares are used nowadays for testing the suspension systems thus reducing costs. Key areas of design were highlighted which ought to be focused upon while designing a suspension system.

V. ACKNOWLEDGEMENT

We respect and thank Mr. S. A. Agrawal for giving us an opportunity to do the project work on “Review on Leaf Spring type Suspension System”. It was his support and guidance which made us complete the paper on time. We are extremely grateful to him for providing his support and guidance in spite of his busy schedule. His extra effort in checking our review on a weekly basis helped to keep me on track and finish my work on time.

REFERENCES

- [1] Michail Malikoutsakis, Georgios Savaidis, Alexander Savaidis, Christoph Ertelt, Franz Schwaiger, “Design, Analysis and Multi-Disciplinary Optimization of High-Performance Front Leaf Springs”, Theoretical and Applied Fracture Mechanics, vol. 83, pp. 42-50, 2016.
- [2] Gerhard Fischer, Manfred Streicher, Vatroslav V. Grubisic, “Durability Approval of Leaf Springs Under Operational Loading”, SAE Paper 982839, 1998.
- [3] N. S. Mendhe, Dr. S. A. Sonawane, Prof. K. C. Raipurkar, ‘Experimental Study and Optimization of Leaf Spring’, International Journal of Engineering Research & Technology, vol. 4 Issue 01, pp.532-536, 2015.
- [4] Medha Santosh Jambhale, J Kale, Mangesh Ramesh Saraf, Arunraj Kumar Govindhasamy, Karl-Eric Köstlin, “Use of Software/ Hardware-in-Loop Technique for Development of Semi-Active Suspension”, SAE Technical Paper 2015-26-0007, 2015.
- [5] Y.S. Kong , S. Abdullah , M.Z. Omara, S.M. Haris, “Failure assessment of a leaf spring eye design under various load cases”, Engineering Failure Analysis, vol. 63, pp. 146–159, 2016.
- [6] V.R.Baviskar, P.L.Sarode, I.N. Wankhede, N.P.Salunke, “Static analysis of master Leaf Spring”, vol. 03 Special Issue: 08, pp. 9-12, 2014.
- [7] A. Donoso, J.M. Chacón, González Rodríguez, F. Ureña, “On an adjustable-stiffness spring composed of two antagonistic pairs of nonlinear leaf springs working in post-buckling”, Mechanism and Machine Theory, vol. 63, pp. 1–7, 2013.
- [8] C.K. Clarke and G.E. Borowski, “Evaluation of a Leaf Spring Failure”, Journal of Failure Analysis and Prevention, vol. 5(6), 2005.
- [9] Stylianos Karditsas, Georgios Savaidis, Michail Malikoutsakis, “Advanced leaf spring design and analysis with respect to vehicle kinematics and durability”, International Journal of Structural Integrity, vol. 6 issue 2, pp. 243-258, 2015
- [10] Bruno Geoffroy Scuracchio, Nelson Batista de Lima, Cláudio Geraldo Schön, “Role of residual stresses induced by double peening on fatigue durability of automotive leaf springs”, Materials and Design, vol. 47, pp. 672–676, 2013.
- [11] Dipendra Kumar Roy, Kashi Nath Sahab, “Nonlinear Analysis of Leaf Springs of Functionally Graded Materials”, Chemical, Civil and Mechanical Engineering Tracks of 3rd Nirma University International Conference (NUiCONE 2012), Procedia Engineering, vol. 51, pp. 538 – 543, 2013.
- [12] Vinkel Arora , Dr. M.L Aggarwal, Dr. Gian Bhushan “A Comparative Study of CAE and Experimental Results of Leaf Springs in Automotive Vehicles”, International Journal of Engineering Science and Technology, vol. 3 no. 9, pp. 6856-6866, 2011.



ISSN(Online) : 2319-8753
ISSN (Print) : 2347-6710

International Journal of Innovative Research in Science, Engineering and Technology

(An ISO 3297: 2007 Certified Organization)

Website: www.ijirset.com

Vol. 6, Issue 1, January 2017

- [13] Anirban C. Mitraa, Tanushri Soni, Kiranchand G. R., Shaizam Khana, Nilotpal Banerjee, "Experimental Design and Optimization of Vehicle Suspension System", 4th International Conference on Materials Processing and Characterization, pp. 2453 – 2462, 2015.
- [14] Basaran Ozmen, Berkuk Altiook, Alper Guzel, Ibrahim Kocyigit, Serter Atamer, "A novel methodology with testing and simulation for the durability of leaf springs based on measured load collectives", 3rd International Conference on Material and Component Performance Under Variable Amplitude Loading, VAL2015, Procedia Engineering, vol. 101, pp. 363 – 371, 2015.
- [15] Priyanka Kothari, Amit Patel, "A Review Paper on Design & Analysis of Leaf Spring", International Journal of Engineering Research & Technology, vol. 3 issue 3, 2014.
- [16] Ishwar Patil, Kiran P Wani, "Design and Analysis of Semi-active Suspension Using Skyhook, Ground Hook and Hybrid Control Models for a Four Wheeler", SAE Technical Paper 2015-26-0084, 2015.