

Study and Analysis of DC – DC Step down Converter

Ubaidulla¹, Satish Kumar J², Malashree G.³Assistant Professor, Department of Electrical & Electronics Engineering, HKBK College of Engineering, Bangalore, Karnataka, India^{1,2,3}

ABSTRACT: The main objective of this paper is to focus on the design and performance of a closed loop DC-DC buck converter system, which can be used to provide robust and high performance power point tracker acting as an intermediate between supply source and load for photovoltaic application. The proposed design includes PI controller for efficient steady state operation. The procedure in terms of selection of components has also been demonstrated. The system was simulated using Power Electronic Simulation (PSIM 9.0). This paper presents the simulation results of constant input voltage of 100V; the buck converter is able to produce 200 W with average 70 percent efficiency.

KEYWORDS: Step Down DC-DC Converter, PI controller, PSIM.

I. INTRODUCTION

In recent decades, research on the use of photovoltaic as an alternative source of energy has become eminent in the field of electrical engineering [1]. A typical photovoltaic energy system compromises DV value at its output side. They are a promising technology and future energy demand in a sustainable and environmentally friendly way. Photovoltaic is made up of cells (solar cell) which are wired together into a module. A number of these cells can be arranged together to produce a much higher voltage. The surface area of a cell and the intensity of the light hitting the panel determine the amount of current produced [2].

A number of modules can be arranged together either in parallel or in series. The amount of DC voltage depends on the arrangement of modules. For instance, four PV modules can reach out 300 Watts when connected in parallel and the value of its output voltage is high. Due to the load specification and the need to provide a lower voltage with high efficiency, a regulator or converter is required in most PV applications in order to step-down the output voltage that they generate. In addition, PV modules require an intermediate power point tracker as their characteristics are nonlinear [3].

The proposed topology in this work is DC-DC buck converter which has the voltage output lower than the input. In order to verify the design methodology, the system was simulated using Power Electronic Simulation (PSIM 9.0) software. The simulation results has shown that the efficiency has been achieved at an average of 70 percent with maximum output power produced of 200W.

II. BUCK CONVERTER

In a buck converter, the average output voltage V_o is less than the input voltage V_i hence the name “Buck”, popularly used as a DC regulator for PV application. The typical circuit diagram of a Buck Converter is as shown in the Fig. 1(a). There are four main components: switching power MOSFET S, freewheeling diode D, inductor L and output filter capacitor C. A switching control circuit monitors the output voltage, and maintains it at the desired level by switching ‘S’ ON and OFF at a fixed rate, but with a varying duty cycle.

A buck converter consists of two operating modes which are continuous conduction mode (CCM) and discontinuous conduction mode (DCM). Usually CCM technique is applied for efficient power conversion while the DCM is for low power and stand-by application [4].

International Journal of Innovative Research in Science, Engineering and Technology

(An ISO 3297: 2007 Certified Organization)

Website: www.ijirset.com

Vol. 6, Issue 6, June 2017

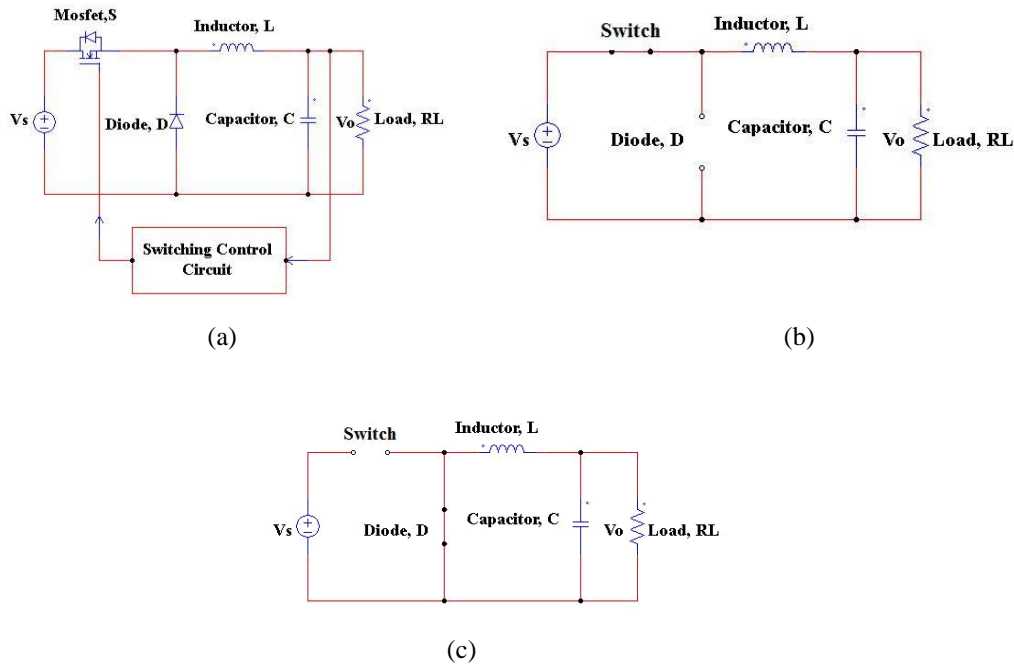

Fig. 1DC-DC step down converter (a) Circuit diagram (b) Circuit Diagram for Charge Phase (c) Inductor Discharge Phase

The principle of operation of buck converter in CCM [5] can be explained in two phases:

1. Inductor charge phase and
2. Inductor discharge phase.

(i) Inductor charge phase: Figure (1b) gives equivalent circuit when switch S is ON. This phase is known as inductor charge phase. During this period, current begins flowing from the input source V_S and inductor 'L', and then into capacitor 'C' and the load (R_L). The magnetic field in inductor L therefore builds up, storing energy in the inductor; with the voltage drop across L opposing or 'bucking' part of the input voltage.

From the above circuit, we can write

$$V_L = V_S - V_0 \dots \dots \dots (1)$$

And

$$L \frac{di}{dt} = V_S - V_0 \dots \dots \dots (2)$$

Integrating equation (1) with respect to dt leads to

$$\Delta I_{Lcharge} = \frac{V_S - V_0}{L} DT \dots \dots \dots (3)$$

Where V_S, V_0, D and $\Delta I_{Lcharge}$ are supply source, output voltage, duty cycle and value of inductor current I_L during charge phase respectively.

(ii) Inductor Discharge Phase: Figure (1c) gives equivalent circuit when switch S is ON. This phase is known as inductor discharge phase. During this period, freewheeling diode gets conducted due to energy stored in the inductor and the inductor current continues to flow through L, C, R and diode D as shown in figure 1d.

International Journal of Innovative Research in Science, Engineering and Technology

(An ISO 3297: 2007 Certified Organization)

Website: www.ijirset.com

Vol. 6, Issue 6, June 2017

From fig. 4,

$$V_L = -V_C = -V_0 \dots \dots \dots (4)$$

And

$$-V_0 = L \frac{dI_L}{dt} \dots \dots \dots (5)$$

Integrating equation (5) with respect to dt leadsto

$$\Delta I_{L\text{discharge}} = \frac{-V_0}{L} (1 - D)T \dots \dots \dots (6)$$

Where V_C is the value of voltage across the capacitor C and is the value of inductor current during discharge state.

(iii) Steady State Operation: Since change in average inductor current is zero [6], from equation (3) and equation (6) we get,

$$\frac{V_s - V_0}{L} DT - \frac{-V_0}{L} (1 - D)T = 0 \dots \dots \dots (7)$$

Therefore,

$$V_0 = DV_s \dots \dots \dots (8)$$

Where, ‘D’ is the duty cycle which can be varied between 0 and 1. So, by varying the switching duty cycle the constant output voltage is obtained for any disturbance in the supply voltage. The current ratio between output and input will be the reciprocal of the voltage ratio; ignoring losses for a moment, and assuming our converter is perfectly efficient.

$$\frac{I_{out}}{I_{in}} = \frac{V_{in}}{V_{out}} \dots \dots \dots (9)$$

(iv) **Condition for CCM:** For the system to operate in continues conduction mode, I_{min} must be greater than zero
Where,

$$I_{max} = V_0 \left[\frac{1}{R} + \frac{1 - D}{2Lf} \right] \dots \dots \dots (10)$$

And

$$I_{min} = V_0 \left[\frac{1}{R} - \frac{1 - D}{2Lf} \right] \dots \dots \dots (11)$$

The minimum value of ‘L’ required for operating the converter in CCM mode is given by,

$$L_{min} = \frac{1 - D}{2f} R \dots \dots \dots (12)$$

The minimum value of ‘C’ required for operating the converter in CCM mode is given by

$$C = \frac{V_0}{\Delta V_0} \times \frac{1 - D}{8Lf^2} \dots \dots \dots (13)$$

International Journal of Innovative Research in Science, Engineering and Technology

(An ISO 3297: 2007 Certified Organization)

Website: www.ijirset.com

Vol. 6, Issue 6, June 2017

III. DESIGN OF PI CONTROLLER

The Figure 2(a) shows block diagram proposed converter system. PI control is a traditional linear control method used in industrial applications. The linear PI controller controllers are usually designed for dc-dc converters using standard frequency response techniques and based on the small signal model of the converter. A Bode plot is used in the design to obtain the desired loop gain, crossover frequency and phase margin. The stability of the system is guaranteed by an adequate phase margin.

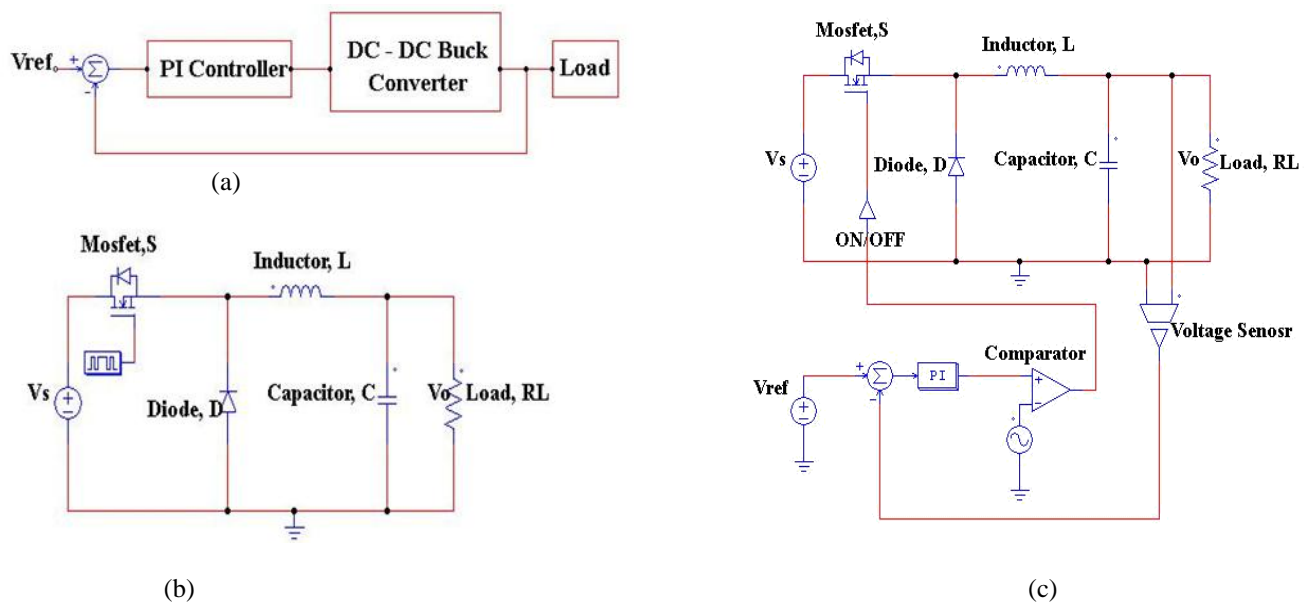

Figure.2. Proposed system(a) block diagram (b) open loop buckconverter (c) Closed loop buck converter.

However, linear PID and PI controllers can only be designed for one nominal operating point. The poles and a right-half plane zero, as well as the magnitude of the frequency response, are all dependent on the duty cycle. Therefore, it is difficult for the PID controller to respond well to changes in operating point. The PI controller is designed for the buck converter for operation during a start-up transient and steady state respectively.

Figure 2(b) and 2(c) shows circuit diagram of open loop the closed loop of the dc-dc buck converter with PI controller. The load voltage of the proposed converter is given to the PI controller. Then the output of the PI controller changes the pulse width of the square wave which changes the firing angle of the MOSFET switch [6], so the output of the converter is controlled for different load disturbances.

IV. SIMULATION RESULTS

For simulation purposes, a buck converter with specifications shown in Table 1 is used. The simulations were performed in order to view the characteristics of the proposed buck converter. The performance of the proposed dc-dc buck converter for open loop and closed loop (PI controller is the feedback controller) were studied and plotted. The simulations were carried out using Power Electronic Simulation (PSIM 9.0) software. Fig. 3(a) and 3(b) shows output voltage waveform of open loop and closed loop buck Converter. For an input voltage of 100 V output voltage is fixed at 50V as shown in figure 3(b) due to feedback system wherein the output voltage is variable as shown in fig (b) for an

International Journal of Innovative Research in Science, Engineering and Technology

(An ISO 3297: 2007 Certified Organization)

Website: www.ijirset.com

Vol. 6, Issue 6, June 2017

open loop system. The input power and output power of buck converter is studied and plotted as shown in the Fig. 3(c). The simulation of the Open Loop Buck Converter is as shown in the Fig. 3(a).

Input Voltage	Output Voltage	Rated Power	Switching Frequency	Load (R_L)
100 V	50 V	200 W	25 kHz	16Ω

Table 1: specifications of proposed converter

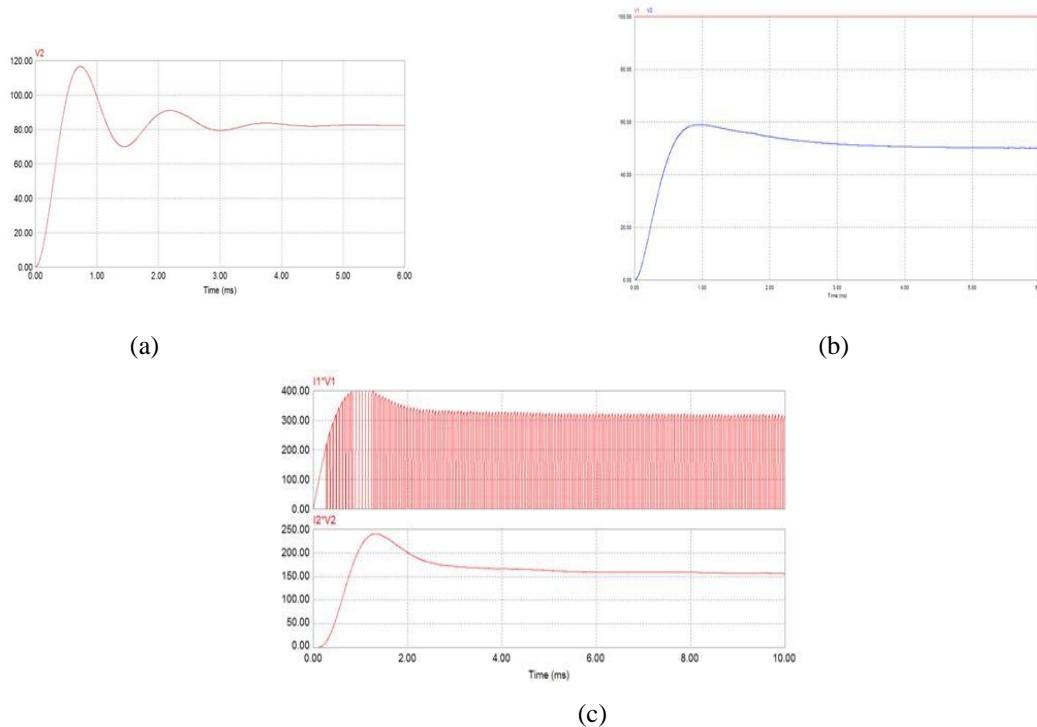

Fig. 3(a) Output voltage waveform of open loop buck converter (b) Output voltage waveform of closed loop buck converter with $V_{OUT} = 50V$ (c) waveforms of input and output power of closed loop buck converter

V. COMPARATIVE EVALUATION

Many researchers explained open loop dc-dc buck converter as shown in the Fig. 2(b) with an average efficiency of 60 percent and with the constant input voltage. The proposed closed loop dc-dc buck converter as shown in the Fig. 2(c) and Fig. 3(b) reduces the steady state error with a regulated output voltage. The proposed design was able to produce 200 Watts with an average efficiency of 70 per cent as shown in the Fig. 3(c)

VI. CONCLUSION AND FUTURE WORK

A robust, efficient and high performance buck converter as an intermediate between the supply source and load can be achieved by carefully choosing a suitable component for the system. A closed loop dc-dc buck converter is designed and

International Journal of Innovative Research in Science, Engineering and Technology

(An ISO 3297: 2007 Certified Organization)

Website: www.ijirset.com

Vol. 6, Issue 6, June 2017

simulated with a feedback control. PI controller is used for feedback control. The output voltage is bucked and it is constant at steady state. It reaches the steady state value within several milliseconds.

In future we can change the load from resistive to Inductive load or motor load. This buck circuit can be implemented to control different special machines like switched reluctance motor, Brushless DC motor etc. We can also change the controller to intelligent controllers like neural network controller, fuzzy logic controller and neuro-Fuzzy logic controller.

REFERENCES

- [1] P. C. M. Bernardo, Z. M. A. Peixoto, L.V. B. Machado Neto, "A high efficient micro-controlled buck converter with maximum power point tracking for photovoltaic systems", International Conference on Renewable Energies and Power Quality Spain, April 2009.
- [2] V. Meksarik, S. Masri, S. Taib, C. M. Hadzer, "Development of high efficiency boost converter for photovoltaic application", National Power & Energy Conference (PECon) 2004 Proceedings, 2004
- [3] M. Veerachary, "Fourth-order buck converter for maximum power point tracking applications," IEEE Trans. On Aerospace and Electronic Systems, vol. 47, Issue No. 2, April 2011 pp 893-911
- [4] S. Khader, "Design and simulation of a chopper circuits energized by photovoltaic modules", 2011 IEEE GCC Conference and Exhibition (GCC) United Arab Emirates, February 2011.
- [5] Syafrudin Masril, Norizah Mohamad, Muhammad Hafeez Mohamed Hariri "Design and development of DC-DC buck converter", IEEE Conference on Power Engineering and Renewable Energy 2012, 3-5 July 2012, Bali, Indonesia
- [6] R. Lakshmi, X. Felix Joseph, Dr. S. Pushakumar, D. Arun Dominic, "Design simulation and analysis of a soft switching scheme for dc-dc boost converter with a closed loop controller" proceedings of ICETECT 2011
- [7] Z. Umanand, S.P. Bhat, "Design of Magnetic Components for Switched Mode Power Converters" New age international (P) Ltd