

OPTIMIZATION OF STEERING GEOMETRY BY DESIGN AND ANALYSIS

Ramesh Kumar. A¹, Jagan. S², Madhu Prakash. K.M³, Jeyabalamurugan. S⁴, Hariharan. M.K⁵

¹Asst.Professor, Department of Mechanical Engineering, Sona College of Technology, Salem, Tamil Nadu, India¹

^{2,3,4,5}Final year UG student, Department of Mechanical Engineering, Sona College of Technology, Salem, Tamil Nadu, India^{2,3,4,5}

ABSTRACT: One of the main causes for the accidents in automobiles is understeering or oversteering at critical turns. These understeer and oversteer effects cause loss of control and makes the vehicle travel beyond the driver's command. The North East London and Essex group of Advanced Automotives have stated that 12.01% accidents are due to miscalculated turning radius. So, the problem is completely in the steering geometry. In this project, an attempt has been made to avoid the aforementioned problems in the steering geometry by modifying its calculations so as to obtain commanded turning radius and complete roll steer in automobiles.

KEYWORDS: Oversteer, Understeer, Turning Radius, Accidents, Roll Steer.

I.INTRODUCTION

According to a survey conducted by the North East London and Essex group of Advanced Automotives, approximately 12% of the road accidents happening per year are due to the miscalculated radius of turn in the vehicles at critical road turns. These miscalculations in steering geometry leads to oversteer or understeer conditions of the vehicle. Thereby the driver's command and control over the vehicle is completely or partially lost resulting in the accidents.

Steering geometry usually followed in all commercial automobiles is understeer geometry which makes the vehicle to travel on a longer radius than the nominal one required for a turn. This is provided in load carriers and passenger cars because of the need for the gradual load distribution in corners to provide passenger comfort, safety and stability. Whereas the steering geometry of sport cars are entirely different from the commercial vehicles. They follow oversteer geometry which makes the car to travel in a shorter radius than the expected radius in order to get an instant response at any moment of turn. So in general, the understeer geometry makes the driver to continuously account for a change in the turning radius to drive through a corner. Oversteer geometry makes a sharp radius that can only be controlled by professional drivers. Due to the inexperience of the drivers, these circumstances causes out of command at some point of time which leads to accidents. These understeer and oversteer are controlled by the Ackermann Angle. It is the angle between the vehicle center and the line joining the bottom pivot to tie rod mount that controls the whole steering geometry.

The North East London and Essex group of advance motorist is a charitable organization devoted to the improvement of road safety by enhancing driver education and is affiliated to the Institute of Advanced Motorists. They have published an article regarding the accidents due to the lack of knowledge on dynamics of automobiles and stated that 12.01% of accidents are due to miscalculated turning radius. These problems are basically discussed in public forum by several automotive enthusiasts whose bottom-line is that the understeer makes the front tires to slip and oversteer makes the rear wheels to slide which makes the vehicle to spin which is actually not true as these kinds of slips and slides have several other factors. However, a better solution to these problems can only be modifications made to the steering geometry. While skimming and reading through various books on vehicle dynamics by renowned authors like Reza N. Jazar [1], Thomas D. Gillespie [2], Mike Blundell and Damien Harty [3], Rajesh Rajamani [4], N. K. Giri [5], William F. Milliken [6], etc., and forums we can draw to a conclusion that there are some trigonometric formulae and relations widespread in many ways to identify the angles and conditions of steering statically but not

dynamically as the radius continuously varies under motion. This makes us clear that these formulae cannot be used. Hence, the work is further extended by determining the Ackermann value and then calculating the rolling percentage that a vehicle is making over a turn. By doing so, the monitoring of the steer of a vehicle through the entire turning angle is possible. Based on the literature survey made and the trial and error analysis performed, it is identified that there is nothing prevailing like more or less Ackermann geometry. Then setting of the Ackermann angle for four wheelers was studied followed by the rolling percent calculations which are actually the two formidable factors affecting the conditions of steer of a vehicle. The steering geometry thus depends only on the track rod length and Ackermann angle both are inversely proportional to each other. Changing any of these will cause a major deflection in rolling percentage graph.

II. MATHEMATICAL STEERING RELATIONS

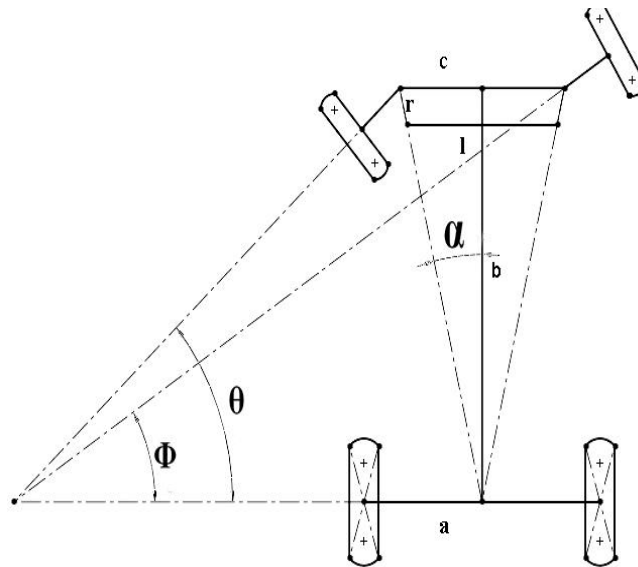

Figure 1: Top View – Left Turn

The various parameters used in the calculations and formulae of the steering geometry are:

- a - track width
- b - wheel base
- c - pivot center
- l - track rod length
- r - length of steering arm
- θ - inner wheel turning angle
- Φ - outer wheel turning angle

Ackermann angle:

Ackermann angle can be calculated from the simple trigonometric calculation,

$$\alpha = \tan^{-1} \frac{c/2}{b}$$

Ackerman condition:

Ackermann condition to determine the relationship between inner and outer wheel.

$$\cot\phi - \cot\theta = \frac{c}{b}$$

Turning radius:

Turning radius is also calculated using a trigonometric relation.

$$R_{of} = \frac{b}{\sin\phi} - \frac{a - c}{2}$$

Rolling percentage:

This calculation is to find the rolling percentage of the vehicle on its turn center. This is the relation that can be applied at any time of a turn and is used to generate graph with inner wheel angle and the roll percent. With the help of the graph we are altering the Ackermann angle to get a 100% rolling performance.

$$ACKERMANN = \tan^{-1} \left\{ \frac{\text{wheelbase}}{\frac{\text{wheelbase}}{\tan\phi} - \text{track width}_{front}} \right\}$$

$$\text{roll percent}\% = \frac{\theta}{\text{ackermann}} \times 100$$

III. ANALYSIS AND SIMULATION

In order to check if the theoretically calculated values meeting 100% rolling performance in the dynamic conditions, a 2D sketch of the axle along with the wheel was drawn in a modelling software. The 2D sketch was drawn for 2 conditions namely:

1. Company provided Steering Geometry
2. Modified Steering Geometry to meet 100% rolling performance

Also, a relation is used to obtain the outer wheel angle with the inner wheel angle over the inner wheel angle in terms of a percentage value which is the percentage of coincidence of all axles.

A real time measurement of the steering geometry in a present car is considered for comparison with the modified calculations steering geometry. The Figure 2 represents the real time geometry provided by an anonymous company in a car. From the geometry, it is clear that the car has an Ackermann angle of 14° for a track width of 47.63” and wheelbase of 72.44”. This is a more common measurement.

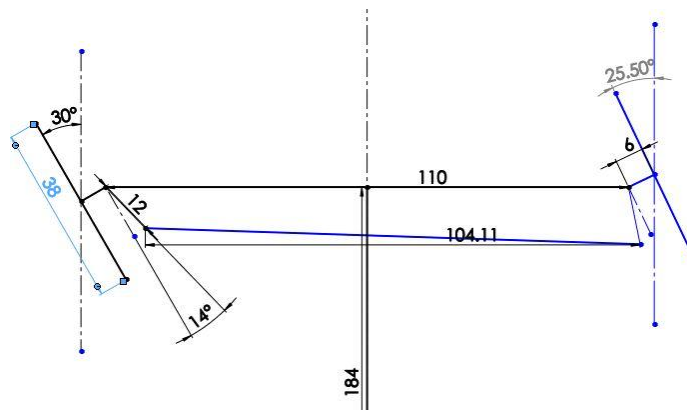

Figure 2: Geometry provided in company

The Ackermann angle was altered in all possible ways and analysed to get a perfect rolling for the vehicle. After several trials on a trial and error basis approach, we finally identified that the angle of 25° provides the maximum rolling percentage. The Figure 3 represents the modified steering geometry.

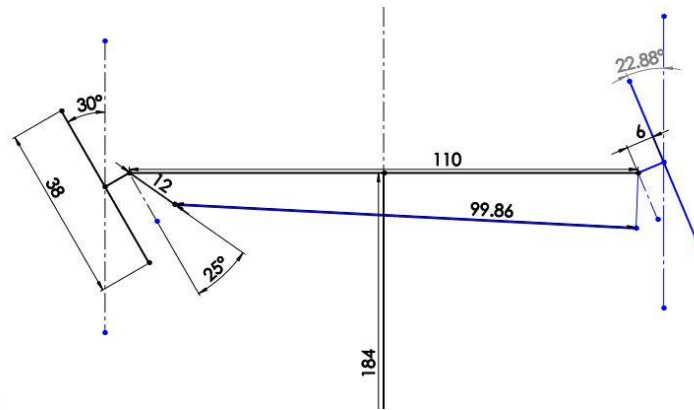

Figure 3: Modified Geometry

The simulation software is used to simulate and take the values of outer wheel angle with respect to inner wheel which includes Ackermann angle and track rod length. With these obtained values the required graphs are generated easily. Figure 4 represents the simulation of the 2D steering geometry using a simulation software.

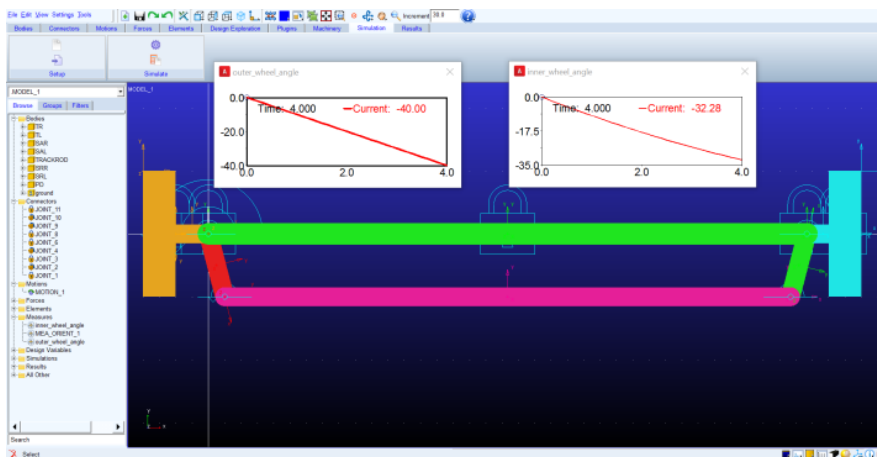

Figure 4: Steering Geometry Simulation

IV. RESULTS AND DISCUSSIONS

From the values obtained in the simulation software, the rolling percentage graphs and the relation between inner wheel and outer wheel are generated.

The Figure 5 shows the graph of rolling percent for Ackermann angle of 14°. The data is clear that the percent of rolling varies from 200 to 96 percent that provides the car to take oversteer which is actually a problem.

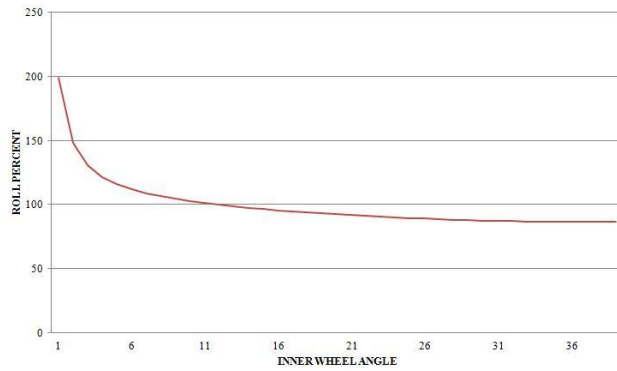

Figure 5: Rolling Percentage graph for company provided geometry

The small change made in Ackermann angle after optimization gives a great change in rolling percentage. The Figure 6 clearly shows the change in rolling percentage of the vehicle to vary from 97 to 105 which is more ideal compared to the company provided steering geometry. This provides the vehicle a good steer with a limited tolerance.

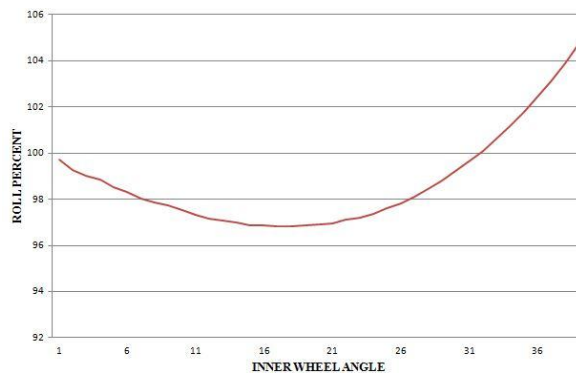

Figure 6: Rolling Percentage graph for modified geometry

The Figure 7 shows the relation between the inner wheel and the outer wheel.

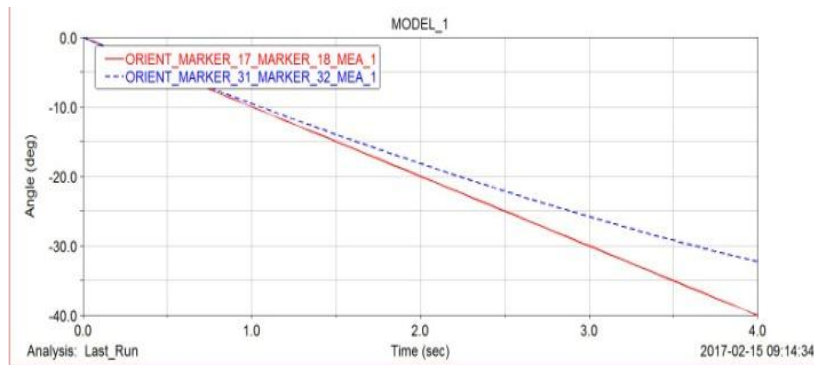

Figure 7: Inner wheel and Outer wheel angle relation

International Journal of Innovative Research in Science, Engineering and Technology

An ISO 3297: 2007 Certified Organization

Volume 6, Special Issue 7, April 2017

5th National Conference on Trends in Automotive Parts Systems and Applications (TAPSA-2017)

30th & 31st March 2017

Organized by

Sri Krishna College of Engineering & Technology, Kuniamuthur, Coimbatore-641008, Tamilnadu, India

V. CONCLUSION

In an attempt to avoid accidents due to oversteer or understeer conditions, calculations of the steering geometry were modified by changing the Ackermann angle from 14° to 25° on a trial and error basis approach as a means to meet the rolling percentage of 100% approximately. A clear graph is generated across the inner wheel angle and rolling percentage. The graph shown in the Figure 5, shows the rolling percentage of stock geometry used in vehicle and the graph shown in the Figure 6, shows the results of new steering geometry.

From the graphs attained, the following conclusions can be drawn:

- New geometry improves 20% - 30% of commanded turning of the vehicle in all conditions.
- The vehicle can take a corner with better speed without slipping or sliding of tires.
- There is a better dynamic activity of the vehicle with good performance roll in the expected radius.

ACKNOWLEDGMENT

I would like to thank Mr. A Ramesh Kumar, Assistant Professor of mechanical engineering department, Sona College of Technology, Salem for his valuable support to develop this project.

REFERENCES

- [1] Reza N. Jazar, "Vehicle Dynamics – Theory and Application", Springer Publications
- [2] Thomas D. Gillespie, "Fundamentals of Vehicle Dynamics", SAE Books Publications
- [3] Mike Blundell and Damien Harty, "Multibody Systems Approach to Vehicle Dynamics", Elsevier Publications
- [4] Rajesh Rajamani, "Vehicle Dynamics and Control", Springer Publications
- [5] Giri N.K., "Automobile Mechanics", Kannan Publication
- [6] William F. Milliken, "Race Car Vehicle Dynamics", SAE Books Publications
- [7] Wong J.Y., "Theory of Ground Vehicles", Wiley Publications
- [8] Carroll Smith, "Tune to Win", SAE Books Publications
- [9] Joseph Edward Shigley, Charles R. Mischke, "Mechanical Engineering Design", Mcgraw Hill, International Edition
- [10] Sharma C.S and Kamlesh Purohit, "Design of Machine Element", Prentice Hall of India Private Limited
- [11] Bansal Dr.R.K. "Theory of Machines" Laxmi Publication (P) Ltd.
- [12] Rajput. R.K "Automobile Engineering" Laxmi Publication (P). Ltd.
- [13] Baja Saeindia forum, Quora, Autocar India forum, FSAE forum