

International Journal of Innovative Research in Science, Engineering and Technology

(A High Impact Factor, Monthly, Peer Reviewed Journal)

Visit: www.ijirset.com

Vol. 8, Issue 8, August 2019

Design and Implementation of a Wind-Solar Distributed Power and Instrumentation System

Ashok Kumar Yadav, Harish Maheshwari

Research Scholar (Power system), RIET, Jaipur, India

Assistant Professor, RIET, Jaipur, India

ABSTRACT: The current paper includes the distribution of electric power control system regarding hybrid production utilizing wind and solar energies in connection. Renewable energy source for instance solar, wind energy etc., provides pure and unlimited energy. When the demand for power rises, the failures of power also increases, hence renewable form of energy might be utilized to provide uniform loads. The primary transformation of electric equation in solar cell form which is developed simply based on fluctuating temperature and solar irradiation. In the present work, PMSG is utilized as wind generator, series of solar, converter dc-dc type, and inverter having grid interface. MPPT (maximum power point tracker) control is required to assure the result outcome from the photovoltaic system of power generation comprised of maximum possible power as output. There are several methods to use MPPT out of which the proposed work comprises of perturbation and observation method (P&O) along with incremental conductance (IncCond) method that are further simulated using the Matlab/Simulink. P&O technique is easy in operation and the need for hardware application is less, nevertheless it comprises of few losses in power.

I. INTRODUCTION

The industry of wind power is among the fastest growing industries due to the outcomes of quick development of the installed capacity. The power of wind from the past two or three decades has become competitive method for pure and green production. In the arriving years it will give much more amount of electricity in several countries. It can be said that in coming years the wind powered energy might become most important source of power generation similar to that of nuclear power system [2]. The question which is raised is by what means the power of wind might impact the complete grid of electricity, to be specific comprising the dispersion of network to which it is linked with. The work of network of distribution is to link up the system of transmission as well as generation on both sides respectively. Such an apparatus of network are termed as passive networks. However, the distribution of sources of renewable energy inside the network distribution transforms the network from passive type to active type. A number of reports have been published on this particular topic [3-11] and they depict that producers engrave in the dispersion of network might importantly effect their operation. The researches have depicted that generators that are embedded are capable of raising the levels of faults to an extent where making reinforcement becomes compulsory, incorporate issues of stability and might cause quality issues of power. The need for exclusive activities for protection so as to give protection to network in regards with non-formal operating situations such as islanding and transient. At the time of formulating new wind based turbines placement of energy attained is not merely the option to get under consideration of planning of phase, effectiveness of cost, influence over the environment on the electric grid are few of the crucial problems.

II. WIND TURBINE SYSTEM DESIGN

Wind energy is utilized from several years as power for sailing ships. Regarding land use, wind mills are utilized by Persia in early 200 B.C. The very first machine powered by wind was the wind wheel of Heron of Alexandria.

International Journal of Innovative Research in Science, Engineering and Technology

(A High Impact Factor, Monthly, Peer Reviewed Journal)

Visit: www.ijirset.com

Vol. 8, Issue 8, August 2019

Moreover, the windmills for practical applications were made in Sistan, a place between Iran and Afghanistan in the 7th century. These were vertical windmills with vertical axles “Panemone”, and comprised of long drive shafts which had rectangular blades. The number of blades was six to twelve which were surrounded by sails of matt fabric. This type of wind mills were utilized to powder up corns or pull out water and were used in industries of sugarcane. Windmills at very starting were illustrated in Europe during the medieval period. The initial record mentioned regarding their application was in 11th century. By the period of 14th century, the windmills from the Dutch were applied in the regions of drain in the delta of Rhine. The initial generating electric power was by the help of a battery in 1887 by James Blyth.

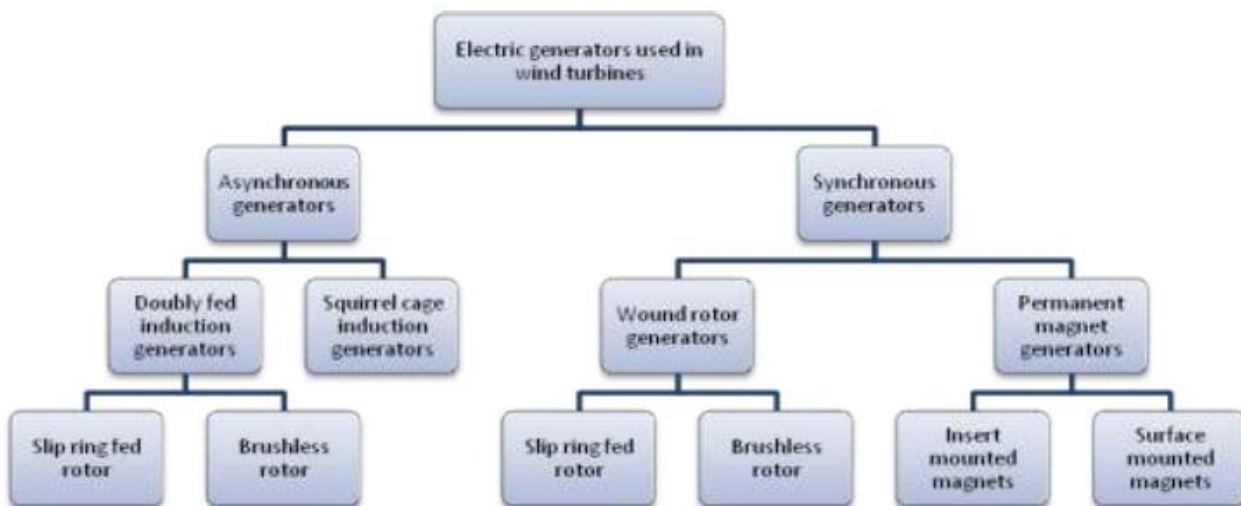

Fig. 1: The classification of electric generator

A solid enthusiasm for utilization of wind turbines as sustainable power sources began amidst 1970's, when worries about the natural impacts of fossil vitality sources use met with the Organization of the Petroleum Exporting Countries (OPEC) oil embargoes. In the course of the most recent four decades the advancement of wind control change innovation has prompted improvement of a few distinct setups of wind turbines, which use a wide assortment of electric generators. The grouping of most regular electric generator types utilized in megawatt go wind

III. PROPOSED METHODOLOGY

MAXIMUM POWER POINT TRACKING (MPPT)

A MPPT is fundamentally a DC to DC converter (electrical). This system is for the most part worked with sun oriented exhibit (PV boards) and few breeze turbines to acquire greatest power transmission and convert it to coordinate with whatever heap it is being associated with utility matrix, battery bank or some other burden. The most well-known trouble of MPPT is that its proficiency shifts with the measure of daylight. At the point when the measure of daylight falling on the board changes, the qualities of the heap changes to a point where the framework can get most extreme power effectiveness. The capacity of MPPT is to find this heap point and keep up the power exchange to ideal and this heap is called greatest power point.

There are a few sorts of MPPT techniques, of them most generally utilized and direct strategies are the Perturb and Observe Method and Incremental Conductance Method. Notwithstanding, there are a few different strategies that are circuitous and are considered very off base on occasion.

International Journal of Innovative Research in Science, Engineering and Technology

(A High Impact Factor, Monthly, Peer Reviewed Journal)

Visit: www.ijirset.com

Vol. 8, Issue 8, August 2019

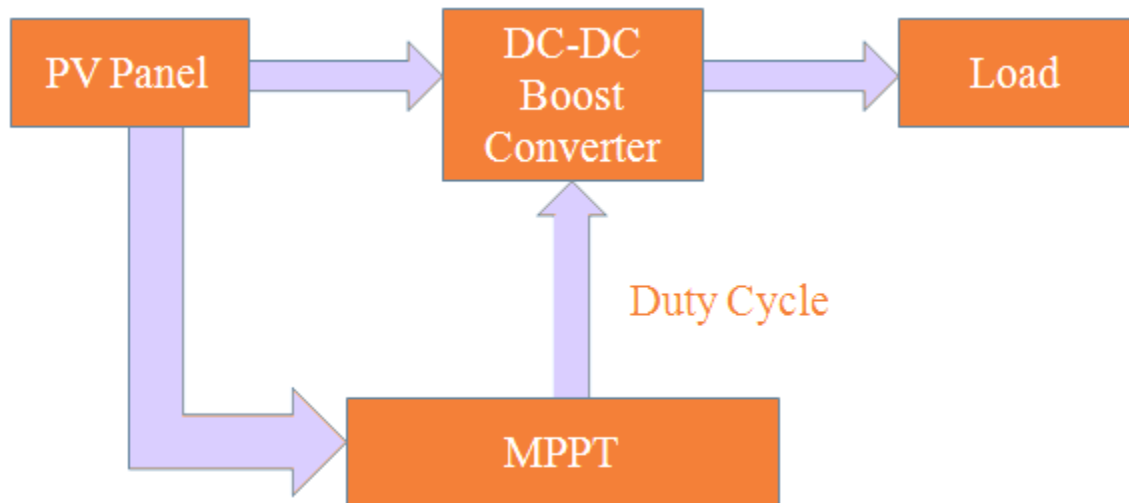

Fig. 2 Circuit Arrangement of MPPT

The profile of the wind and the speed of the wind over any particular area needs to be estimated initially to recognize what kind of turbine is suitable for that region. The wind turbine cover around 70% of the total project it very important that it creates optimum electric power for that area. For lower speeds for wind, regions several changes and modifications are done on the turbine.

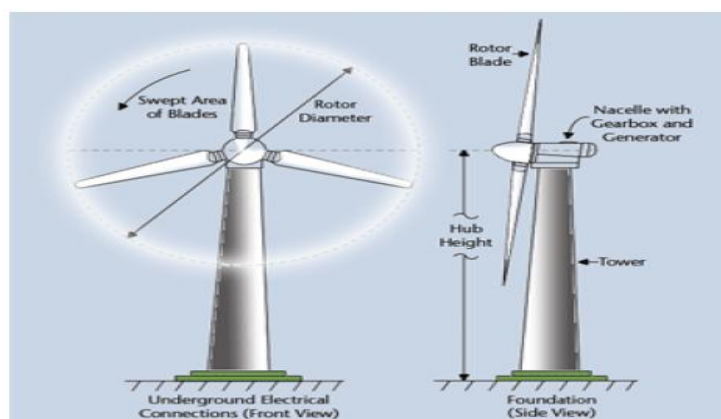

Fig.3 Rotor and Blades of wind turbine

The rule of wind turbines control age is transformation of the air motor vitality into turning mechanical intensity of the turbine cutting edges. As of now in time the most widely recognized utilized breeze turbine is the even pivot propeller type, having a few cutting edges mounted on the highest point of a pinnacle.

International Journal of Innovative Research in Science, Engineering and Technology

(A High Impact Factor, Monthly, Peer Reviewed Journal)

Visit: www.ijirset.com

Vol. 8, Issue 8, August 2019

IV. PROPOSED MODEL

The proposed framework presents control techniques of a lattice associated crossover age framework with adaptable power exchange. This half and half framework permits greatest use of openly accessible sustainable power sources like breeze and photovoltaic energies. For this, a versatile MPPT calculation alongside standard irritates and watches strategy will be utilized for the framework.

Additionally, this setup permits the two sources to transmit the load isolate and mutually at the same time based on the source of energy that is available. The turbine rotor speed is the fundamental determinant of mechanical yield from wind vitality and Solar cell working voltage on account of yield control from sun based vitality. Permanent Magnet Synchronous Generator is combined with wind turbine for accomplishing wind vitality transformation framework.

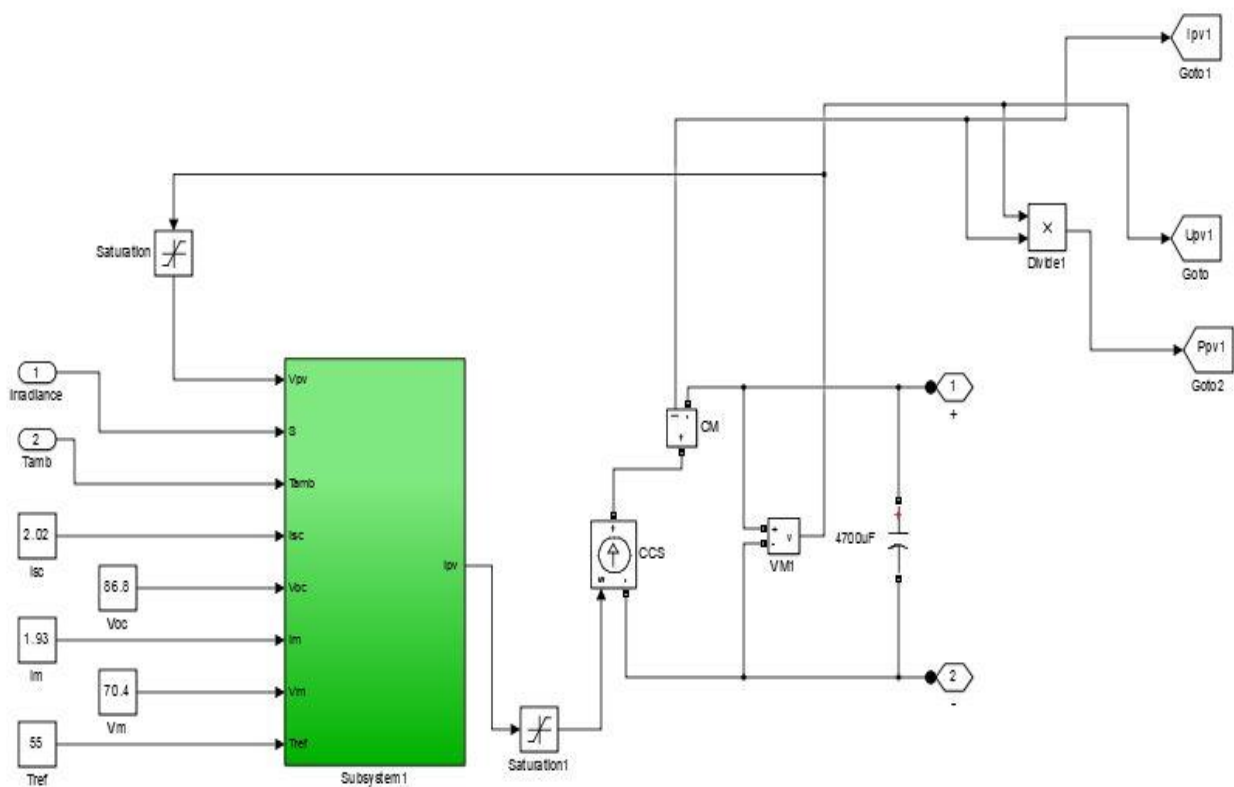

Fig. 4 Model of PV array

International Journal of Innovative Research in Science, Engineering and Technology

(A High Impact Factor, Monthly, Peer Reviewed Journal)

Visit: www.ijirset.com

Vol. 8, Issue 8, August 2019

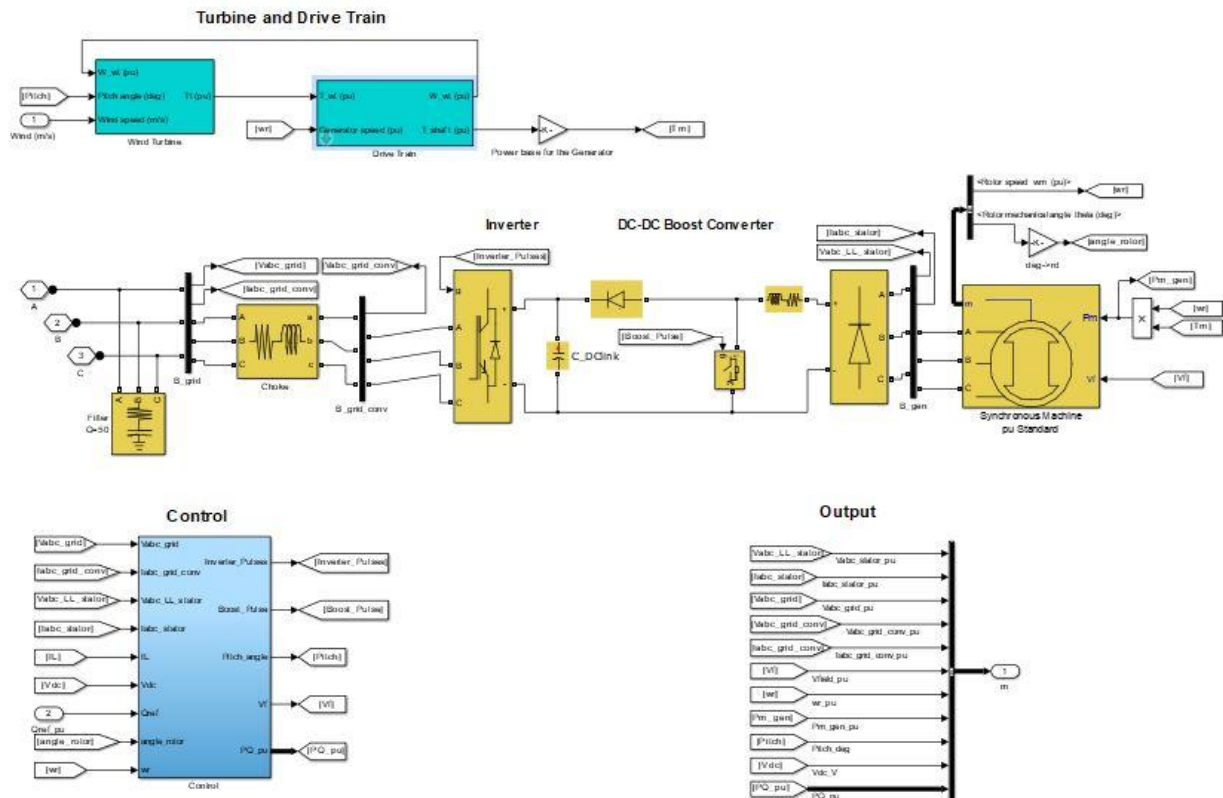

Fig. 5 Model of wind turbine

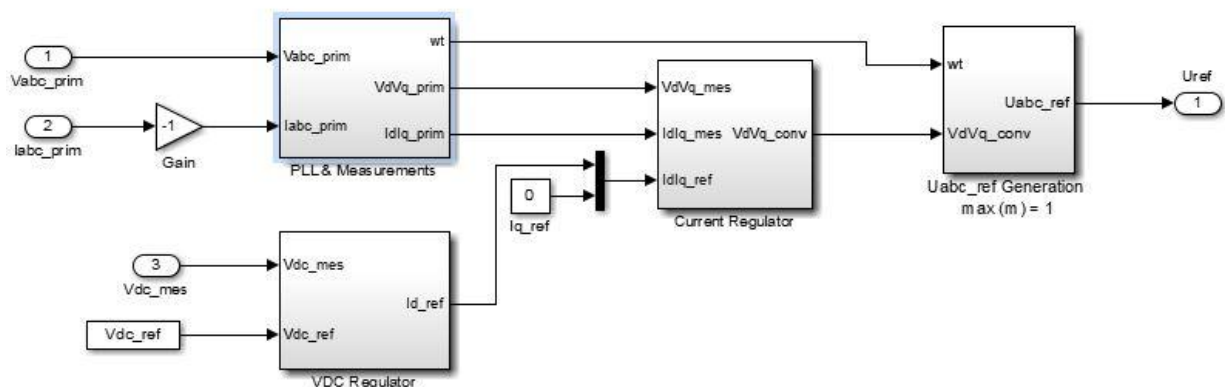

Fig. 6 Model of VSC control

International Journal of Innovative Research in Science, Engineering and Technology

(A High Impact Factor, Monthly, Peer Reviewed Journal)

Visit: www.ijirset.com

Vol. 8, Issue 8, August 2019

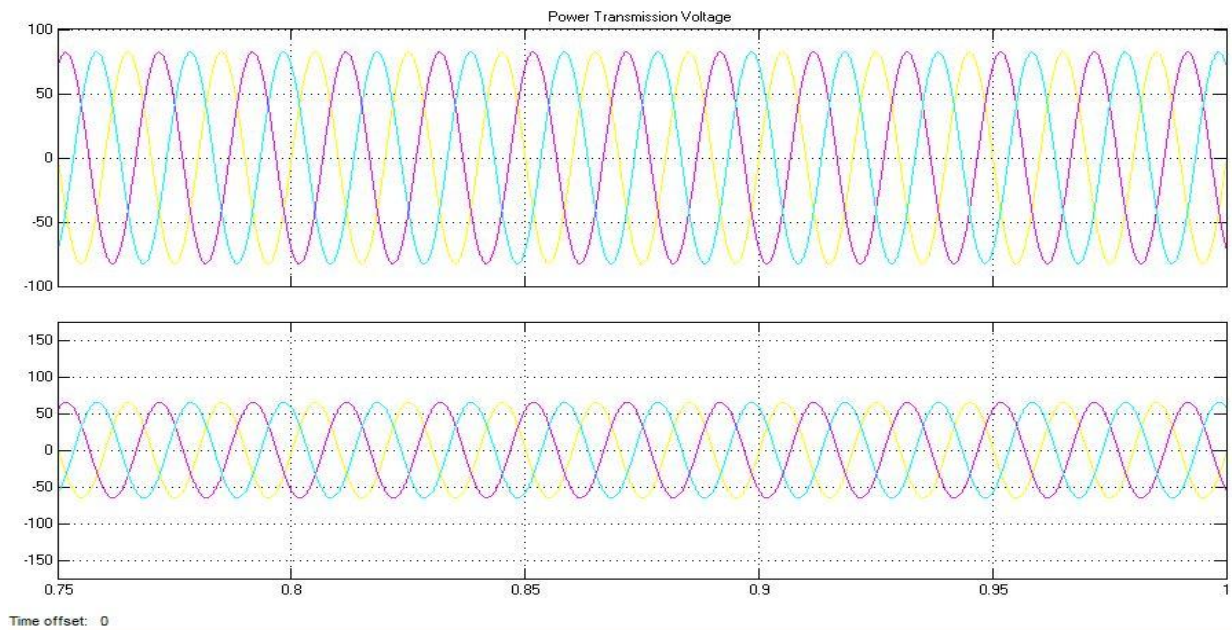

Fig. 7 Power Transmission voltage of transformer

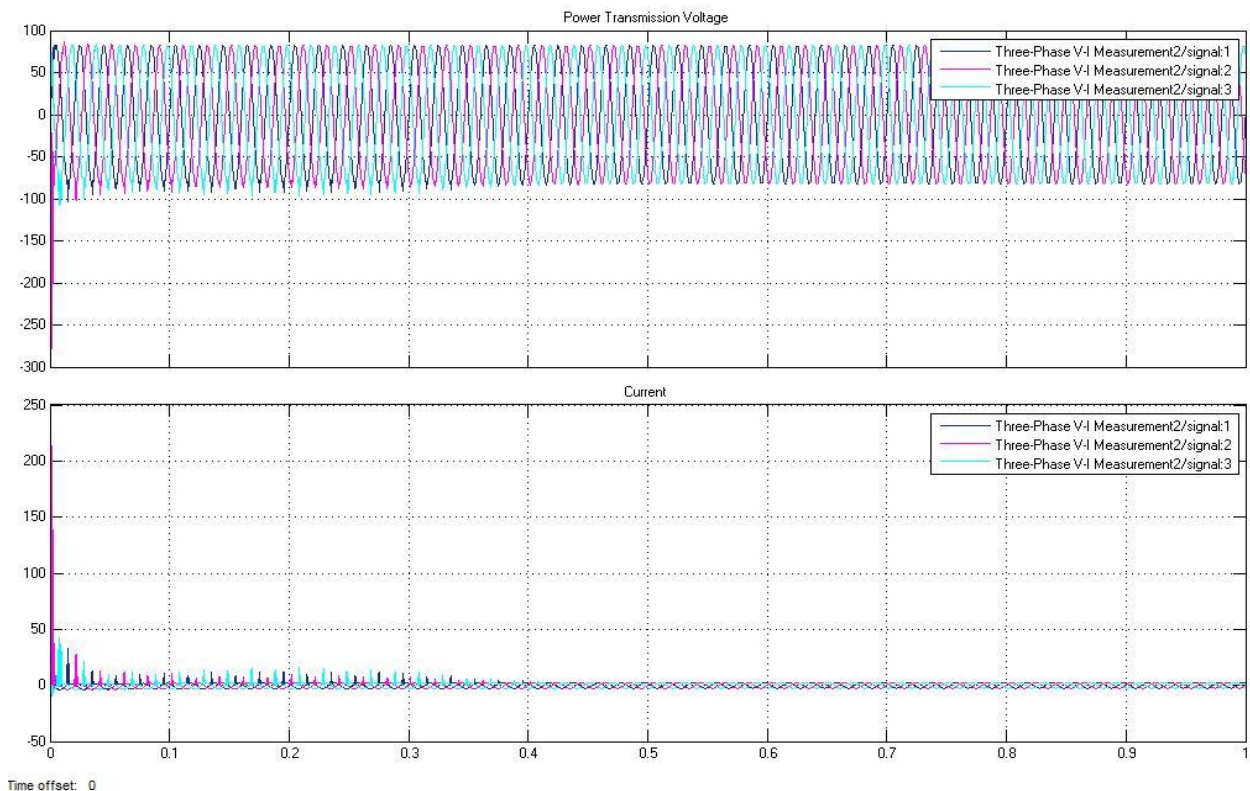

Fig. 8 Power Transmission voltage of system

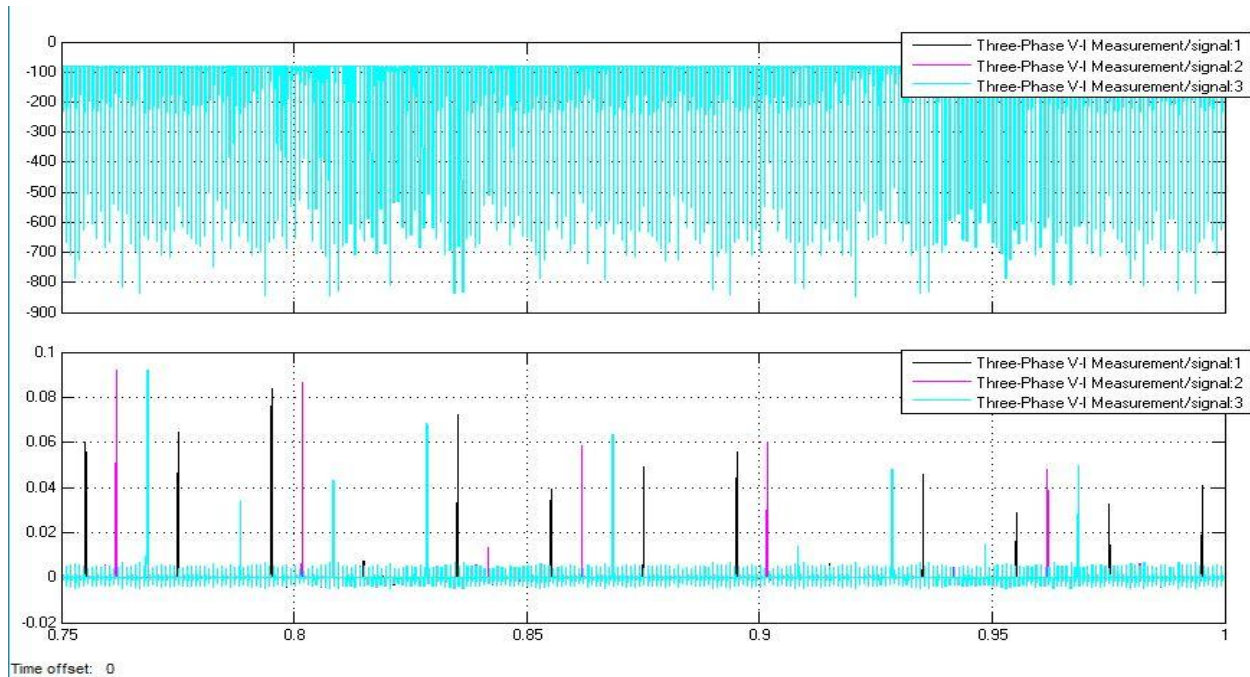

Fig. 9 Power transmission voltage of inverter

V. CONCLUSION

A proficient control strategy that is (P&O) ought to be picked. The interface of source voltage of inverter along with the grid transmits the energy retained from the turbine setup and the range of PV towards the grid by maintaining a mutual voltage of dc uniform. Based on this evaluation, it was found that it is firmly possible to forecast the result from power exactly from the linked up grid range of PV that adds up impact of temperature and radiation of sun. The reproduction results demonstrate the control execution and dynamic conduct of the half and half wind-PV framework. The recreation accomplished the make proficient and viable Hybrid framework which could be utilized for both private and modern reason with the goal that it is financially savvy and advances high utilization of environmentally friendly power vitality.

VI. FUTURE WORK

In future combination of other hybrid system along with this on goingsuch as fuel cell or battery system can be incorporatedand simulations can be performed on MATLAB.

For future research we want to create a more advanced and bigger hybrid system with which we can implement for industrial purpose. We expect after implementing this system in an industry that the cost recovery will be much faster than that of residential use and it will be more cost effective in the long run.

REFERENCES

- [1.] Abderrahim, T. and Said, B. (2017) 'Control and Management of Grid Connected PV-Battery Hybrid System Based on Three- level DCI', pp. 439–444.
- [2.] Al-durra, A., Reznik, A. and Muyeen, S. M. (2014) 'Performance Analysis of a Grid-tied Inverter for Renewable Energy Applications'.
- [3.] Chen, F. (2012) 'Modeling Grid Connection for Solar and Wind Energy', pp. 1–6.
- [4.] Dali, M., Belhadj, J. and Roboam, X. (2010) 'Hybrid solar e wind system with battery storage operating in grid – connected and standalone mode: Control and energy management e Experimental investigation V bat', *Energy*. Elsevier Ltd, 35(6), pp. 2587–2595. doi:

International Journal of Innovative Research in Science, Engineering and Technology

(A High Impact Factor, Monthly, Peer Reviewed Journal)

Visit: www.ijirset.com

Vol. 8, Issue 8, August 2019

- 10.1016/j.energy.2010.03.005.
- [5.] Gupta, P. and Tripathi, S. K. (2014) 'Analysis of Grid-Tied Hybrid Wind PV Generation System', (November), pp. 447–451.
 - [6.] Hassan, S. Z. *et al.* (2015) 'Stand-alone / Grid-tied Wind Power System with Battery / Supercapacitor Hybrid Energy Storage', (DI), pp. 1–6.
 - [7.] Mahmud, N., Zahedi, A. and Mahmud, A. (2016) 'Dynamic voltage regulation of grid-tied renewable energy system with ANFIS'.
 - [8.] P, L. R. S. *et al.* (2014) 'Design and Simulation of Grid Connected Hybrid Solar-WECS Using SIMULINK / MATLAB', pp. 241–247.
 - [9.] Patel, S., Prajapati, N. and Patel, T. (2016) 'Grid Connected Solar and Wind Hybrid System', 2(12), pp. 300–307.
 - [10.] Phap, V. M., Yamamura, N. and Ishida, M. (2016) 'Design of Novel Grid-Tied Solar - Wind Hybrid Power Plant Using Photovoltaic Cell Emulating System', (1), pp. 186–189.
 - [11.] Soetedjo, A. *et al.* (2017) 'A Hardware Testbed of Grid-Connected Wind-Solar Power System', 1(2), pp. 52–56.
 - [12.] Soysal, O. A. (2014) 'Case Study : Performance of a Small Grid-Tie Wind-Solar Generation System', (2007), pp. 2007–2008.