

Analysis and Developments of SUV Vehicle Chassis using Finite Element Method

Selvamanikandan.M¹, Venkatesan.S²

P.G. Scholar, Department of Mechanical Engineering, VMKV Engineering College, Salem, Tamil Nadu, India¹

Professor, Department of Mechanical Engineering, VMKV Engineering College, Salem, Tami Nadu, India²

ABSTRACT: The chassis is one of the vehicle's main assemblies and all subassemblies are connected to the chassis. Upper body and pay loads are transferred to the wheels through the chassis. This chassis development is used for M1 category SUV vehicles. At the vehicle level, the engine, radiator, fuel tank, power transmission and suspension are connected to the chassis. Therefore, this various assembly must be represented in sub-assembly level developments. This assembly is represented by a lumped mass element with COG and connected to the corresponding mounting position by an RBE3 element. This assembly has been tested with the FEA solver for various load cases, including 1 or 3 gravity fields, natural frequencies, bending, torsion, uphill combinations, acceleration and cornering, pothole and cornering case inertial relaxation. This chassis should meet the requirements with minimal deflection and no failure in all load cases. In this study, the performance of the chassis is improved by adjusting the section modulus of the ladder frame without greatly changing the mass value. The main challenge is also that the chassis front member deforms and absorbs the collision energy during vehicle collisions, to reduce the G-force and intrusion in the passenger compartment, so that the strength of the chassis should increase without affecting the flexibility.

KEYWORDS: Chassis, M1-Vehicle, FEA Simulation, Chassis development, Chassis Performance, 1G, 3G, Natural Frequency, Modal Analysis, Bending Analysis, Twisting Analysis, Combination of uphill, acceleration and cornering Analysis, Inertia relief Analysis, pot hole Analysis, cornering Analysis.

I. INTRODUCTION

The chassis is the important structural of a Vehicle, which is used to connect the entire subassembly to the vehicle. As the vehicle travels, the chassis is subjected to dynamic forces from road surface roughness, and vibration of engine and transmission system. Due to the Static forces and dynamic excitation, the chassis tends to vibrate, leading to ride comfort, ride comfort and structural stability issues. These mechanical problems involve complex nonlinear boundary conditions that are difficult to solve mathematically by analytical techniques. This difficulty is overcome by seeking some form of numerical solution. Finite element method (FEM) is the most appropriate and accurate numerical method for solving complex problems.

Cicek Karaoglu [3] performed stress analysis of chassis with actual loading condition and revert holes to optimize the chassis. Due to the revert holes the chassis flexibility increased and prevented from high stress area in the frames. H.J. Beermann [4] made a combination study of analytical and finite element studies of chassis in static and dynamic condition. Analysis has shown that increasing the thickness of the side members can reduce the stress at the joints, but it is important to recognize that the overall weight of the chassis frame increases. Using local plates only in the joint area will also increase the thickness of the side members. Therefore, additional weight of the chassis frame is controlled. Kallappa Khannukar [5] conducted Vibration and frequency response analysis to find the vibrational dynamic behaviour of the chassis. And from the analysis, chassis modes and mode shapes were extracted, also obtained the value of the natural frequency for chassis. The present research study is validate the base line design with static, vibrational analysis with Inertia relief analysis. Along with this improve the design to improve the performance with considerable mass variation.

International Journal of Innovative Research in Science, Engineering and Technology

(A High Impact Factor, Monthly, Peer Reviewed Journal)

Visit: www.ijirset.com

Vol. 8, Issue 8, August 2019

II. FINITE ELEMENT METHOD - MODEL INFORMATION

FEA is a powerful mathematical method to solve the complex nonlinear mathematical problems with computers. Chassis design model is converted from design model to the FEA model by using appropriate elements and joints.

2.1 Elements parameters

The sheet parts of the chassis are model with shell elements (Quad and Tria). The meshing are made in the mid plane of the components and thickness assigned to that elements, These elements will extrude both side equally to represent the thickness. Bolts are model with 1D-beam elements with corresponding diameters. Welds are represented by using rigid RBE2 elements. Elements average size is 5mm. and the quality parameters are shown in the fig2.1

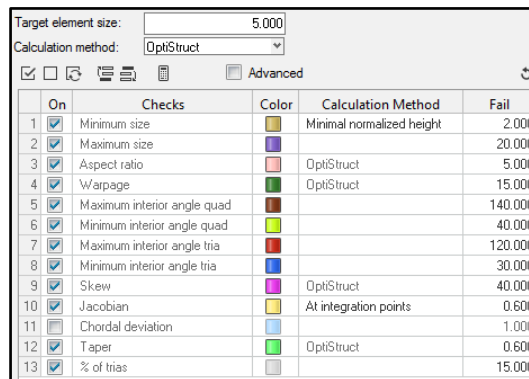

| On | Checks | Color | Calculation Method | Fail |
|-------------------------------------|-------------------------------|--------|---------------------------|---------|
| <input checked="" type="checkbox"/> | 1 Minimum size | Orange | Minimal normalized height | 2.000 |
| <input checked="" type="checkbox"/> | 2 Maximum size | Purple | | 20.000 |
| <input checked="" type="checkbox"/> | 3 Aspect ratio | Red | OptiStruct | 5.000 |
| <input checked="" type="checkbox"/> | 4 Warpage | Green | OptiStruct | 15.000 |
| <input checked="" type="checkbox"/> | 5 Maximum interior angle quad | Brown | | 140.000 |
| <input checked="" type="checkbox"/> | 6 Minimum interior angle quad | Yellow | | 40.000 |
| <input checked="" type="checkbox"/> | 7 Maximum interior angle tria | Red | | 120.000 |
| <input checked="" type="checkbox"/> | 8 Minimum interior angle tria | Blue | | 30.000 |
| <input checked="" type="checkbox"/> | 9 Skew | Purple | OptiStruct | 40.000 |
| <input checked="" type="checkbox"/> | 10 Jacobian | Yellow | At integration points | 0.600 |
| <input type="checkbox"/> | 11 Chordal deviation | Blue | | 1.000 |
| <input checked="" type="checkbox"/> | 12 Taper | Green | OptiStruct | 0.600 |
| <input checked="" type="checkbox"/> | 13 % of trias | Grey | | 15.000 |

Figure 2.1 Element Quality Parameters of Chassis Mesh

2.2 Assembly mass and COG information

The assembly of vehicle is represented by mass elements with their COG point location. Since, modeling of full assembly will increase the run time with much change in the results. The mass and center of gravity details are shown in the table 2.1

Table 2.1 Mass and COG information of Vehicle

| S.No | Assembly | Mass (Kg) | COG | | |
|------|-----------------------|----------------|-------------|------------|------------|
| 1 | Chassis | 317 | X=-2543.16 | Y=-8.4368 | Z=415.307 |
| 2 | All-Upper Body | 954.2 | X= -2522.26 | Y=9.6351 | Z=868.38 |
| 3 | Engine & Transmission | 363.3 | X= -1090 | Y= -7.6504 | Z=630.188 |
| 4 | Radiator | 30.56 | X= -360.53 | Y= 4.3557 | Z=675.66 |
| 5 | Fuel Tank | 49.05 | X= -2590.53 | Y= 279.75 | Z=333.221 |
| 6 | Front Power Train | 50.22 | X=-965.25 | Y= 88.53 | Z=345.53 |
| 7 | Rear Power Train | 107.4 | X= -3597.62 | Y= 6.304 | Z=378.72 |
| 8 | Front-Wheel assembly | 155.7 | X= -828.955 | Y= 3.57 | Z=388.9117 |
| 9 | Rear-Wheel assembly | 184.5 | X= -3700.92 | Y=-1.4466 | Z=364.149 |
| 10 | Exhaust System | 32.23 | X=-2349.22 | Y=222.468 | Z=357.5 |
| | TOTAL MASS | 2244.16 | | | |

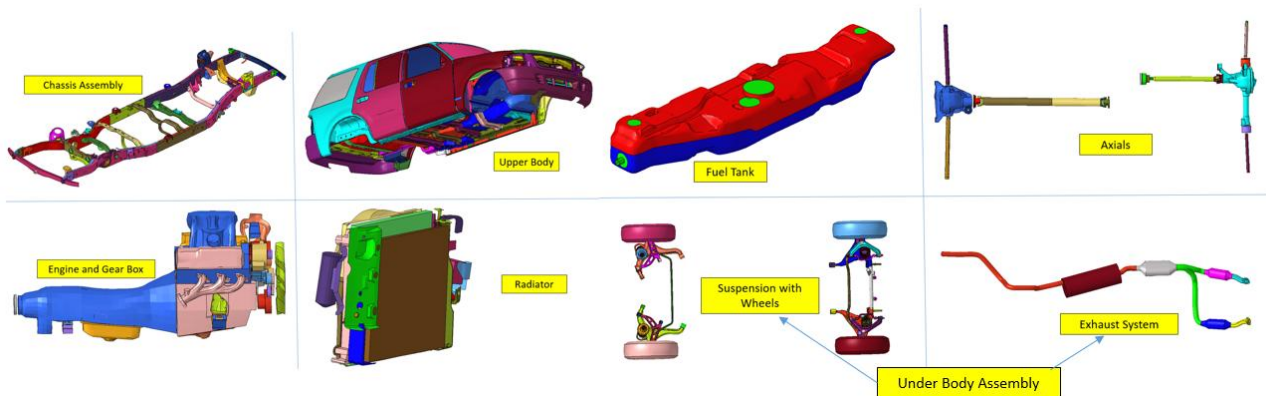

Figure 2.2.1 vehicle subassembly

III. DESIGN AND DEVELOPMENTS OF CHASSIS PARAMETERS

The Chassis Design and dimensions are shown in the fig 3.1, the overall dimension is 4922mmX 1030mm. In the Study Flat ladder chassis consider for the SUV vehicle and the mounting coordinates are fixed based on the sub assembly design, so the chassis developments should perform without changing the mounting locations.

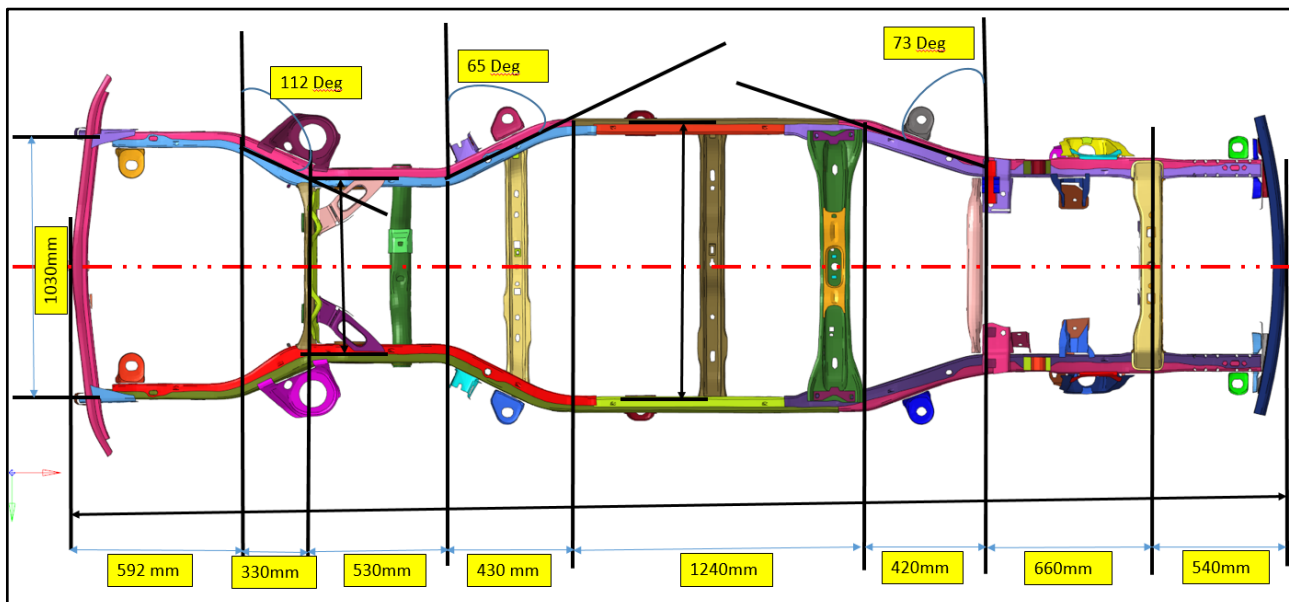

Figure 3.1 Chassis Dimension

3.1 Various Design of Chassis Frames:

The chassis development process has four different design shown in the fig. 3.2

DV1 is 3mm thickness single C section frames.

DV2 is 5mm thickness single C section frames.

DV3 is 5mm thickness Single C Section with Reinforcement frames added.

DV4 (Final) different thickness (2.6mm~3.7) Double C Section frames.

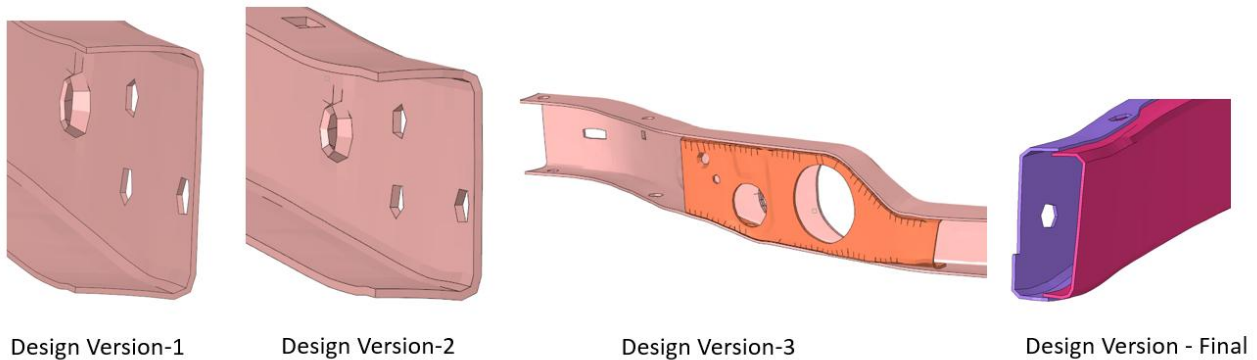

Figure 3.2 Chassis various Design Improvements

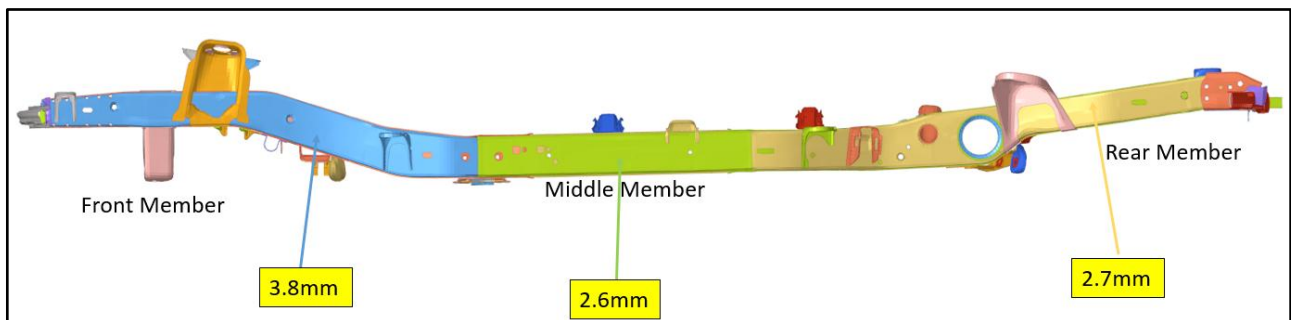

Figure 3.3 Different thickness of Ladder frames

3.2 Material Details

In the chassis assembly has different material and different thickness for parts. Mainly three type of DOCOL material used in the chassis assembly, Front members are 800CP, Middle members are 1200M and rear members are 700LA. The material linear and nonlinear properties are shown in the table 3.1

Table 3.1 Material information for Chassis

| Material Name | Linear Properties | Non Linear Properties | Application |
|---------------|--|--|--|
| DOCOL 1200M | Density= 7.8e-9 Tonne/mm ³ Young's Modulus=2.1e5 Mpa Poisson's Ratio= 0.3 | Yield Strength=950 Ultimate Strength=1200 Fracture Strain=5% | Helps improve crashworthiness and ensures a lightweight design |
| DOCOL 800CP | Density= 7.8e-9 Tonne/mm ³ Young's Modulus=2.1e5 Mpa Poisson's Ratio= 0.3 | Yield Strength=570 Ultimate Strength=780 Fracture Strain=10% | Helps improve crashworthiness and ensures a lightweight design |
| DOCOL 700LA | Density= 7.8e-9 Tonne/mm ³ Young's Modulus=2.1e5 Mpa Poisson's Ratio= 0.3 | Yield Strength=700 Ultimate Strength=820 Fracture Strain=10% | Consistent properties for modern, rapid production methods |

IV. CHASSIS FEA LOAD CASES

The Chassis assembly has model in the FEA, and all sounding parts represented in the FEA. Optistruct solver is used to perform the chassis load cases, this chassis validated in the following list of load cases.

1. Modal Analysis
2. 1Gravity
3. 3Gravity
4. Bending stiffness analysis
5. Twisting stiffness analysis
6. Combination of uphill 7 degree, acceleration and cornering
7. Inertia Relief – Pot hole Analysis
8. Inertia Relief – Cornering Analysis

4.1. Modal Analysis

The FEA model of chassis shown in the fig 4.1 for modal analysis setup. Modal Analysis is performed to find the natural frequency of the chassis assembly to avoid the resonance with other sub-assemblies.

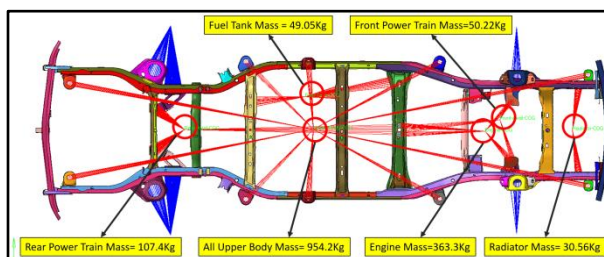

Figure 4.1 FEA Model for Modal analysis

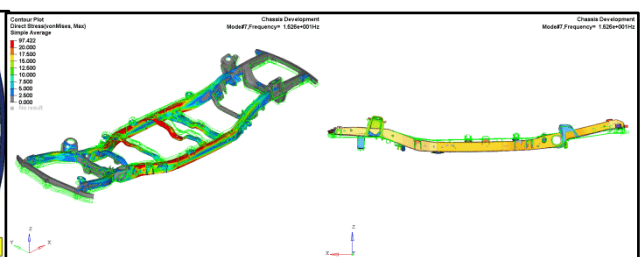

Figure 4.2 Modal analysis Result- Bending mode (15.26Hz)

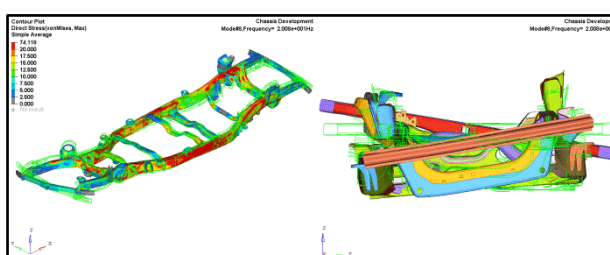

Figure 4.3 Modal analysis Result- Twisting mode (20 Hz)

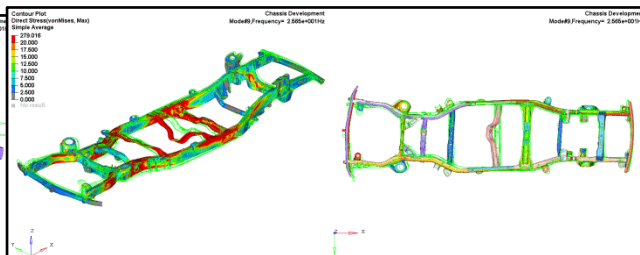

Figure 4.4 Modal analysis Result- Lateral mode (25.6 Hz)

4.2 1G/3G Static Analysis

In the chassis 1 gravity ($1 \times 9.81 \text{ m/sec}^2$) load and 3 Gravity ($3 \times 9.81 \text{ m/sec}^2$) load applied and study the structural behaviour of the members with stress and displacements values. This load case will represent the vehicle at static condition.

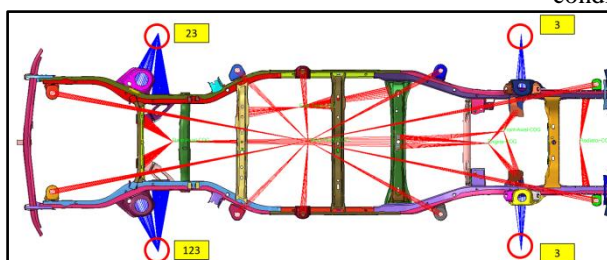

Figure 4.2.1 1g/3g load case - Finite Element Model

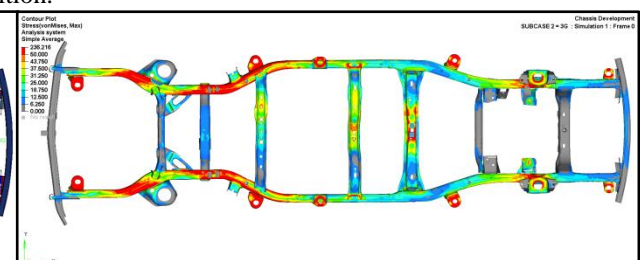

Figure 4.2.2 3g load case – Stress contour

4.3 Bending Stiffness Analysis

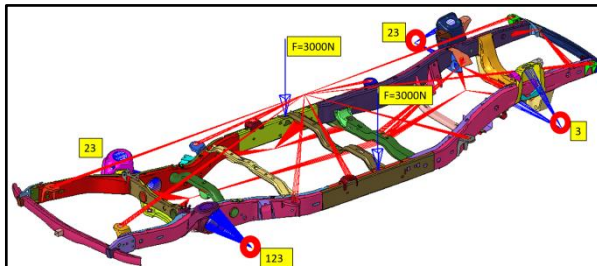

Figure 4.3.1 Bending Analysis- FEA Model

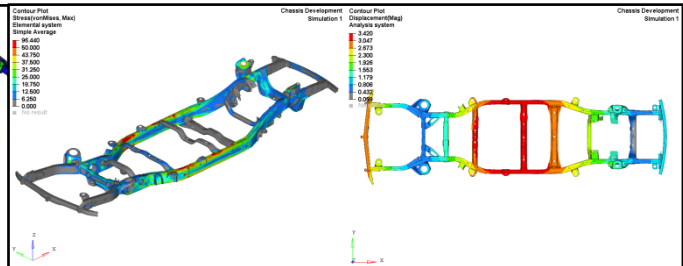

Figure 4.3.2 Bending Analysis- Stress-Displacement Contours

$$\text{Bending Stiffness} = \text{Load} / \text{Displacement}$$

$$= 6000\text{N} / 3.420 = 1754.38 \text{ N/mm}$$

4.4 Torsional Stiffness Analysis

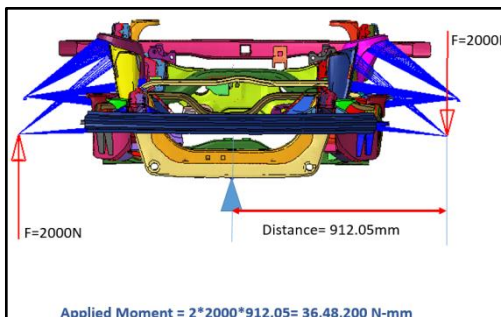

Figure 4.4.1 Twisting Analysis- FEA Model

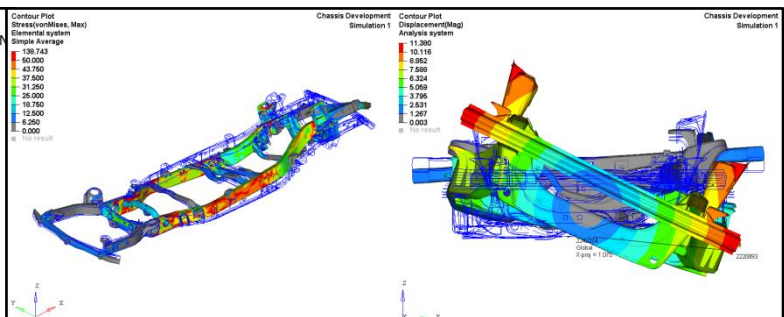

Figure 4.4.2 Twisting Analysis- Stress-Displacement Contours

$$\text{Stiffness} = \text{Moment} / \text{Angle of Rotation}$$

$$= 3000\text{N} / 3.420 = 877.19\text{N/degree}$$

4.5 Combination Load case Analysis

Combination of 7 deg uphill, Acceleration and cornering load case on the chassis shown in the fig 4.5.1.

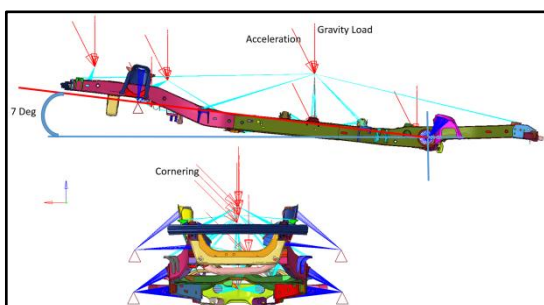

Figure 4.5.1 Combination Analysis- FEA Model

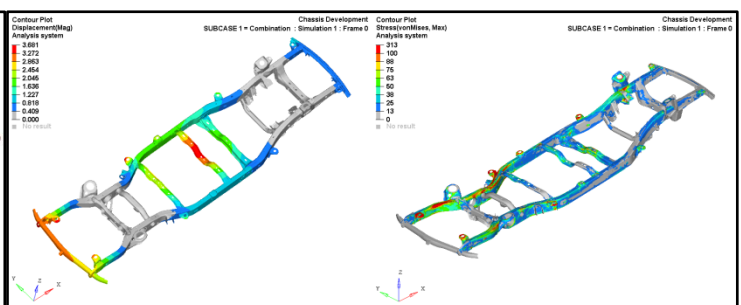

Figure 4.5.2 Combination Analysis- Stress-Displacement Contours

4.6 Inertia Relief Analysis

4.6.1 Pot Hole Inertia Relief Analysis

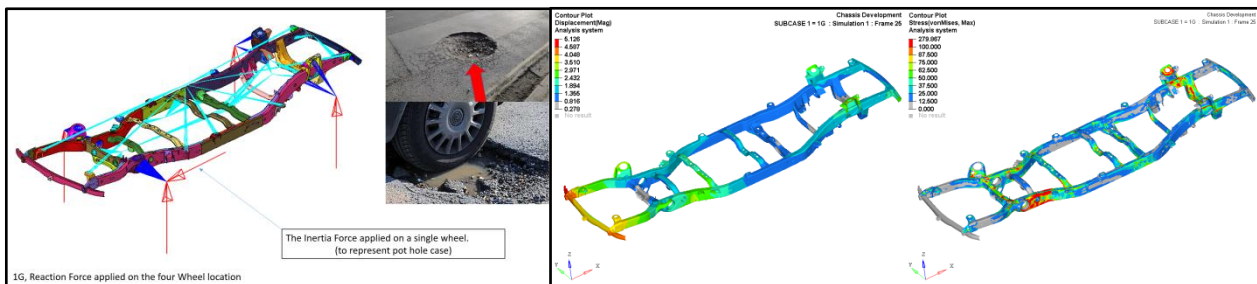

Figure 4.6.1.1 Pot Hole Inertia Relief Analysis- FEA Model

Figure 4.6.1.2 Pot Hole Inertia Relief Analysis- Displacement Stress Contours

4.6.2 Cornering Inertia Relief Analysis

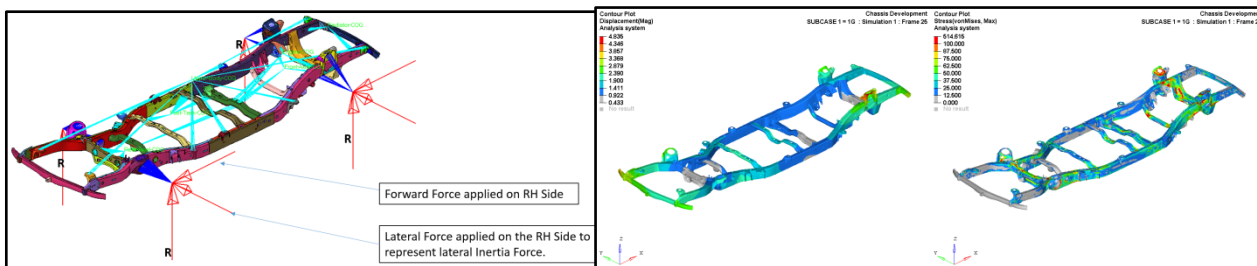

Figure 4.6.2.1 Cornering Inertia Relief Analysis- Finite Element Model

Figure 4.6.2.2 Cornering Inertia Relief Analysis- Displacement Stress Contours

V. RESULTS AND SUMMARY OF ITERATIONS

| S.No | Load Case | DV-1 | | DV-2 | | DV-3 | | DV-4(Final) | |
|------|-----------|---|-----------|--|-----------|---|-----------|---|-----------|
| | | Stress (Mpa) | Disp (mm) | Stress (Mpa) | Disp (mm) | Stress (Mpa) | Disp (mm) | Stress (Mpa) | Disp (mm) |
| 1 | Modal | Bending = 9.1Hz Twisting = 9.8Hz Lateral = 18HZ | | Bending = 11 Hz Twisting = 12 Hz Lateral = 22 HZ | | Bending = 12 Hz Twisting = 14Hz Lateral = 22 HZ | | Bending = 15 Hz Twisting = 20 Hz Lateral = 25HZ | |
| 2 | 1G | 405 | 5.9 | 213 | 3.7 | 213 | 3.7 | 80 | 1.26 |
| 3 | 3G | 1218 | 17.8 | 640 | 11.2 | 639 | 11.2 | 243 | 3.79 |
| 4 | Bending | 254 | 16.4 | 164 | 5.7 | 121 | 4.36 | 103 | 3.4 |
| 5 | Twisting | 591 | 52.1 | 480 | 33.5 | 455 | 30.8 | 173 | 14.79 |

International Journal of Innovative Research in Science, Engineering and Technology

(A High Impact Factor, Monthly, Peer Reviewed Journal)

Visit: www.ijirset.com

Vol. 8, Issue 8, August 2019

| | | | | | | | | | |
|----|-------------|------------|------|------------|-------|------------|------|-------------|------|
| 6 | Combination | 1667 | 33 | 934 | 20.11 | 933 | 20 | 313 | 3.68 |
| 7 | Pot Hole | 736 | 17.7 | 438 | 10.11 | 438 | 9.6 | 279 | 5.12 |
| 8 | Cornering | 731 | 23.1 | 452 | 13.46 | 450 | 12.6 | 514 | 8.32 |
| 10 | Mass | 1.83 Tonne | | 1.88 Tonne | | 1.89 Tonne | | 1.857 Tonne | |

VI. CONCLUSION FUTURE SCOPE OF WORK

In the current research on chassis development has concluded with following information,

- The performance of the design version 1 (3mm) single C section frame chassis is very low in all load cases, and the twisted load case is the worst case of DV1.
- The design version 2 (5mm) single C section frame chassis load case performed better than the DV1, but this performance is not enough for this SUV.
- Design version 3 (5mm) single C section with reinforced frame, chassis load case performance is almost the same as DV2, so performance will not improve much.
- Design version 4 (various thickness 2.6-3.8mm) double C section frame chassis load case performance is very good, stress and displacement values are greatly reduced.

Therefore, this DV4 chassis works well in all chassis load cases, Also this chassis need to perform well in crash load cases. It must deform and absorb more crash energy in order to increase the occupant safety.

The future scope of this research is Fatigue, durability, Vibration analysis and crash Analysis for DV4 Chassis.

REFERENCES

- [1] Nitin S. Gokhale. (2008). "Practical Finite Element Analysis". Finite To Infinite. ISBN: 8190619500
- [2] Julian Happian-Smith (2001). "An Introduction to Modern Vehicle Design" Elsevier ISBN: 0750650443
- [3] Cicek Karaoglu, N. Sefa Kuralay (2001) 'Stress analysis of a truck chassis with riveted joints'. Elsevier: Finite Elements in Analysis and Design V.38 (2002) 1115-1130
- [4] H.J. Beermann, (1989) "The Analysis of Commercial Vehicle Structures", Mechanical Engineering Publication Limited, Vol.5 PP. 28-46.
- [5] Kallappa Khannukar (2015) 'Dynamic Analysis of Automotive Chassis using FEA' IRJET. Vol: 02 Issue: 09.
- [6] Monika S.Agrawal (2015) 'Finite Element Analysis of Truck Chassis Frame' IRJET. Vol: 02 Issue: 03
- [7] Rajappan.R (2013) 'Static and Modal Analysis of Chassis by Using FEA' Ijes. Vol: 02. Issue: 02 PP: 63-73.
- [8] Pritam R. Kanade (2017) 'Finite Element Analysis of Automobile Chassis' GRD Journals. Vol: 02 Issue: 07 PP: 130-133.
- [9] Avinash V. Gaikwad (2014) 'Finite Element Analysis of a Ladder Chassis Frame' IJETMAS, Vol: 02. Issue: 06. PP: 19-26.
- [10] Santa Rao.K (2016) 'Finite Element Analysis of a Four Wheeler Automobile Car Chassis' IJST, Vol: 09(2)