

International Journal of Innovative Research in Science, Engineering and Technology

(A High Impact Factor, Monthly, Peer Reviewed Journal)

Visit: www.ijirset.com

Vol. 8, Issue 11, November 2019

Adaptive Neuro Fuzzy Inference System Based Solar Energy Planning

Mayank Singh Parihar¹, Manoj Kumar Jha²

Research Scholar, Dr C.V. Raman University, Kota, Bilaspur, India¹

Professor, Department of Mathematics, K.T.C. College, Salni, Janjgir-Champa, India²

ABSTRACT: For centuries humans have designed buildings and settlements to take advantage of light and heat from the sun. While many of these design techniques fell out of favor with the advent of fossil-fuel-produced heat and electricity, in recent years communities across the India and throughout the world have taken a renewed interest in both passive and active solar energy use. In many industrialized nations, rising fuel prices and concerns over energy security during the 1970s planted the first seeds of the modern market for solar energy production. However, these initial investments in solar technology remained quite modest until the first decade of the twenty-first century. Solar energy is a community resource and should, therefore, be treated as such. The planners, public officials, and other community stakeholders can use to foster opportunities for solar energy use and evaluate solar development opportunities. A long term prediction of future load is helpful in better operation of solar power systems and its economical utilization. A number of algorithms have been suggested for solving this problem. In this paper ANFIS, for long term load forecasting is proposed. In this paper the relationship between the humidity, temperature and load is identified with a case study for a particular region in India. The output load obtained is corrected which depends on the previous set of loads, number of customers etc. The data is taken for the three years and the results are obtained for the fourth year. It is further validated using the actual data from an electrical company.

KEYWORDS: ANFIS, Load Forecasting, Neuro-Fuzzy Modelling, Energy consumption, Solar energy Planning.

1. INTRODUCTION

1.1 Solar Energy as a Local Resource

The concept of conventional energy reserves (such as our nation's oil, gas, or coal reserves) is readily understood by most planners. Similarly, at the local level, planners routinely assess their communities' economic, natural, and social (or human) resources in order to set priorities and make planning and development decisions but what about our communities' solar resources, the solar energy "reserves" available for development? While every community has solar resources, very few consider how planning and development decisions affect the future availability of local solar resources or opportunities for private-sector solar development.

International Journal of Innovative Research in Science, Engineering and Technology

(A High Impact Factor, Monthly, Peer Reviewed Journal)

Visit: www.ijirset.com

Vol. 8, Issue 11, November 2019

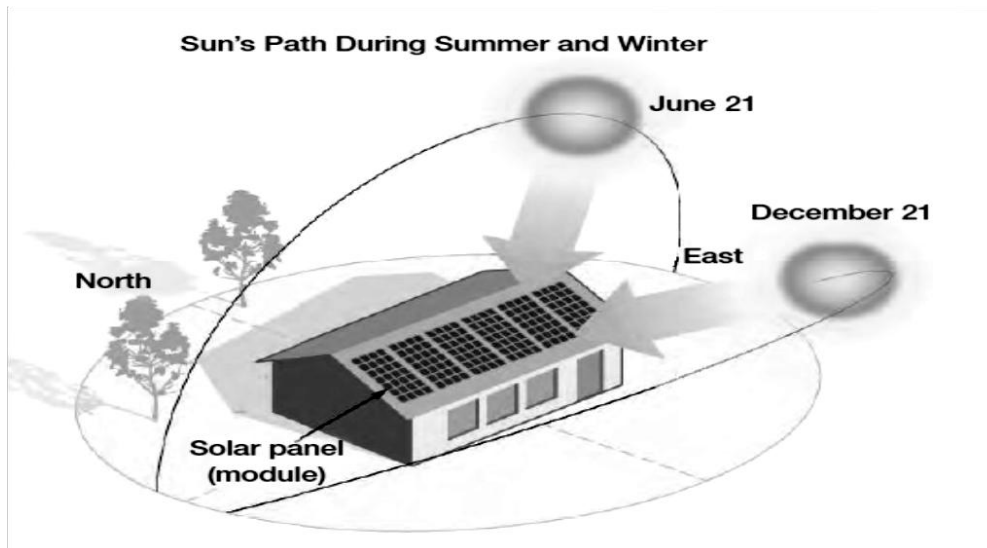

Fig.1 South-facing roof maximizes solar access

1.2 The Solar Resource

Solar irradiance, or solar radiation, refers to the electromagnetic energy that emanates from the sun. Because solar radiation can be harnessed to produce heat and electricity, it makes sense to look at it through the lens of resource management. While every location on earth receives some amount of solar radiation, a number of temporal, atmospheric, and geographic variables affect the quantity and quality of the solar resource available at a particular location.

The effects of time of day and season

The rotation of the earth means that the local solar resource varies throughout the day, with peak potential at midday when the sun is at its highest point in the sky. However, the local solar resource also varies by season. Because the earth's axis is tilted approximately 23.4 degrees to its orbital plane, the southern hemisphere is closer to the sun during the period between the summer and fall equinoxes.

The effects of atmospheric conditions

Air molecules, clouds, water, and particulate matter (including pollution and dust) all limit the amount of solar radiation that reaches the surface of the earth at any given time and location. Sunlight that passes through these obstructions has less energy than unobstructed solar irradiance. A number of factors influence local atmospheric conditions, including altitude, weather patterns, and the prevalence of human activities that produce pollution (e.g., driving and heavy industry).

The effects of latitude and the local landscape

Because the earth is spherical, solar radiation hits the surface of the earth at different angles throughout the year based on latitude. As the angle of entry increases, the amount of atmosphere the sunlight must pass through increases. In other words, lower latitudes receive more solar radiation throughout the year than higher latitudes. At the site level, though, the local landscape has a much greater effect on the solar resource available to a particular location. Structures, vegetation, and topography can limit the amount of solar radiation that reaches a specific site. Based on the factors discussed above, in the northern hemisphere the shading effects of these local landscape features are most profound when they are located on the adjacent south side of the site (Fig.1).

International Journal of Innovative Research in Science, Engineering and Technology

(A High Impact Factor, Monthly, Peer Reviewed Journal)

Visit: www.ijirset.com

Vol. 8, Issue 11, November 2019

Measuring the solar resource

The term *insolation* refers to the amount of radiant energy from the sun that strikes a given surface area over a period of time. When discussing solar energy use, the two most common insolation metrics are kilowatt-hours per square meter (kWh/m²), which relates to electricity production, and British thermal units per square foot (Btu/ft²), which relates to heat production.

1. Solar Photovoltaic Systems

Solar photovoltaic (PV) systems use photovoltaic cell technology to harness radiant energy from the sun and create electricity. These cells are often packaged into panels that can be placed on rooftops or mounted on the ground. The cells can also be incorporated into other building materials such as roofing materials, facades, and even glass in an arrangement that is commonly known as “building-integrated PV.” Since most PV cells produce direct current, or DC, electricity, an inverter is often added to the system to convert the output to alternating current, or AC, electricity, the form of electricity that most appliances and the electricity grid are designed to use.

One of the foremost benefits of PV technology is its flexibility to accommodate a range of uses. PV has been successfully implemented on homes, businesses, manufacturing facilities, and even utility-scale projects comparable in size with large fossil-fuel generation facilities.

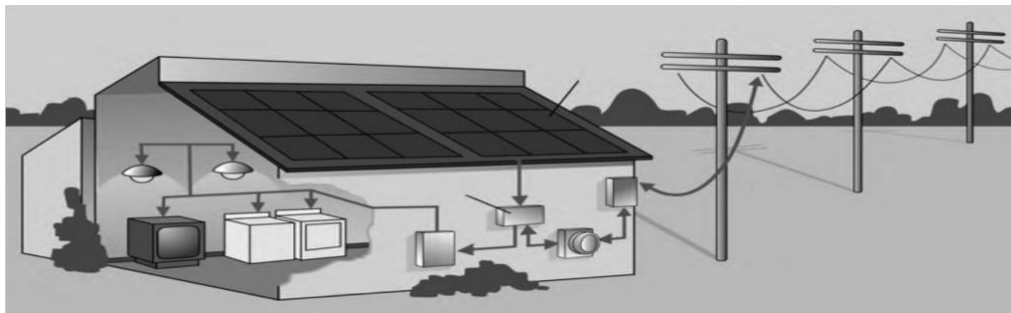

Fig.2 This diagram shows components of a typical residential grid-connected PV system

1.1 Interconnection

Interconnection refers to the technical and procedural requirements necessary to safely, reliably, and efficiently connect an electricity-generating system (e.g., a PV system) to the electricity grid. In order for a PV system to net meter, rather than rely on batteries to store the electricity, the system must be interconnected. The interconnection process sets forth guidelines and criteria in order to allow electricity to flow from the PV system out into the grid.

1.2 Solar in the comprehensive plan

The comprehensive plan, sometimes referred to as the general plan or the master plan, is the foundational policy document for local governments. In many ways it functions like a community constitution, establishing a framework for future growth and change within the jurisdiction to be implemented through local laws and public investments over the next 20–25 years. Given the importance of the comprehensive plan in the local planning system, it represents a logical point to introduce goals and objectives related to solar energy use in the context of the wider local policy framework. This gives plan authors a chance to highlight synergies and potential conflicts between solar development and other community resources and to summarize any previous, ongoing, and planned policies and actions to support the implementation of goals related to promoting solar energy use.

1.3 Solar in subarea plans

Subarea plans are plans that include goals and objectives for a discrete geographic area within a jurisdiction. Some common types of subarea plans include plans for specific sectors, neighborhoods, corridors, or special districts, such as transit station areas, redevelopment areas, or areas designated for historic preservation. These plans may cover a wide

International Journal of Innovative Research in Science, Engineering and Technology

(A High Impact Factor, Monthly, Peer Reviewed Journal)

Visit: www.ijirset.com

Vol. 8, Issue 11, November 2019

range of topics relevant to the plan area, essentially functioning as smaller-scale comprehensive plans, or they may be strategic in nature, focusing on a subset of topics with special urgency.

II. NEED OF SOLAR POWER

Here are some more reasons you might want a solar power system, despite the inefficiencies and costs involved. Two or more reasons might be related, such as green energy and independent living. No problems choose the relevant ones and decide if they give you the value you want. Perhaps you live in an area where commercial electrical power is frequently interrupted by storms or other events. A solar power system can act like a large uninterruptable power supply (UPS) for your house. You might not even know when the grid power fails unless you're using a high-power appliance at the time. Your computer and TV will stay on, and the lights might not even flicker. Any solar power system will lower your electric bill, but a grid-tied system will lower it more than a non-grid-tied system.

2.1. Solar panels

Let's start at the beginning. Photovoltaic panels convert sunlight into electricity. These PV (or solar) panels often are mounted on the roof of a house, but they also may be mounted on a framework installed on the ground. The panels must be tilted to face the sun. The tilt angle is always a compromise, because the sun moves across the sky from east to west during the day, and changes maximum elevation during the year. Some people install their solar panels on tracking mounts which use motors to follow the sun's movements. These "trackers" add considerable cost to a system.

2.2 Batteries

Many, but not all, solar power systems include batteries to store energy from the PV array for use when the sun is not shining. If you don't have batteries, your system can provide power only during sunny periods. Usually batteries are lead-acid types similar to the one in your car. A solar power system places high demands on batteries, so special "deep-cycle" batteries are used instead of regular automotive batteries.

2.3 Inverter

The inverter's job is to convert DC power supplied by the batteries into 120 or 240 volts AC at 50Hz., and to synchronize its frequency to the electric grid, if the system is connected to the grid. The batteries are wired to inverter's input through a high-current circuit breaker, and the inverter's output is wired to a breaker box in the house, so it can supply power to designated household appliances. If the system is grid-tied and is approved to sell power to the utility, the inverter performs that function as well. To sell power, the power must originate with a "green" energy source such as PV panels or a wind or water turbine. In other words, to be sold, the energy must come through the charge controller and not be needed for charging the batteries or powering household loads.

2.4 Grid-tie considerations

Grid-tied means being connected to the grid and capable of selling excess solar energy to the electric utility. A grid-tied inverter sends AC power produced from a renewable source (e.g., solar, wind, hydro) to the grid via the *input* cable. Normally we think of an inverter putting AC power on its *output* cable to run appliances, but in this case it puts it on its input cable.

III. POWER SYSTEM OPERATION PLANNING

Under a set of operational conditions such as composition of generators, generator characteristics, automatic generation control and economic load dispatch, an operator plans a generation schedule typically for the next day. In the schedule, start and stop timing and generation level of each generator are decided to fit the predicted demand of various levels during the day. The operation plan of a power system, called as unit commitment, is a result of large-scale optimization planning considering economy, stability and security of the power system operation. The economy is mainly dependent on the operational cost of each power plant including fuel cost and generation efficiency of a thermal unit. The operational stability is mainly related to the total capability of all generators to change its output. The security is

International Journal of Innovative Research in Science, Engineering and Technology

(A High Impact Factor, Monthly, Peer Reviewed Journal)

Visit: www.ijirset.com

Vol. 8, Issue 11, November 2019

ensured through the reserved generation units which may work in a sudden increase of demand or in a sudden loss of generation due to a generation failure. If there is not enough balancing capability in a power system, it may be necessary to curtail the variable PV generation to secure the stability of the system operation, even if it reduces the economy of the system. In the context of operation planning, the natural variation of PV generation increases the requirement demand-and-supply balancing capability of a power system which results in partial operation of some power plants. The uncertainty of PV generation requires additional operation of generation units with lower economy in preparation for the event of reduced PV generation. In the unit commitment including the power market operation, PV forecast plays a crucial role to decide the performance of a power system operation. In the power system operation planning, in order to keep the viability of the analysis, we need to include the parameters such as maintenance schedule of power system elements are as following:

IV. POWER SYSTEM AUGMENTATION PLANNING

In years, demand and generation mix changes in a power system. In order to reduce CO₂ emission in the energy sector, it is widely recognized that energy demand will increase as economy grows in general, the existing power demand will reduce through energy efficiency, much of energy demand will be electrified, and more energy will be supplied by variable renewable generation, which leads to a larger power demand and supply structure with a higher share of variable renewable generation including PV.

In the current practices of power system augmentation planning, a planner, following criteria such as economy, reliability, environmental, stability and security, optimize the future power system. When a power system augmentation is planned including RE such as PV, it is usually aimed to find the optimum path to integrate RE into a power system. In order to develop such a future power system, the power system augmentation planning must have the new functionalities so as to accommodate substantial variable renewable generation, while satisfying the existing planning criteria and constraints. The impacts of PV penetration on the power system come with the variation and limited predictability of PV generation, and the reduction of the operational amount of dispatchable generators. Possible countermeasures include improvement of load following capability and reduction of minimum operation of existing and new thermal and hydro generators, improvement of PV forecast, demand activation and utilization of energy storage including a pumped storage power plant and batteries.

In the power system augmentation planning, the parameters which are used in the operation planning are necessary to estimate the operational performance of each augmentation scenarios. In the augmentation planning, the time horizon is the most important parameter. A major thermal generation needs several years of legal procedures and construction period. The distributed generators also need long time for being properly disseminated. The augmentation planning usually has 10 to 20 years of study period.

V. FORECASTING

Forecasting can reduce the uncertainty associated with variable renewable energy generation technologies. This allows generators or grid operators to plan generation service or balancing services ahead of variations in the output of solar and wind generators and reduce the level of operating reserves needed, thus lowering the cost of balancing the system. Short-term forecasts assist in the dispatch of quick-start generators, demand response mechanisms, or other methods to quickly balance demand and supply. Forecasts are more widely used to predict wind power generation variability, but solar forecasting is emerging. Cloud movements are the primary cause for solar variability, besides diurnal cycles. Sky imagers can be used to produce short-term forecasts, whereas satellite images can be used to predict changes in solar power production over a span of a few hours.

VI. PLANNING

a. Comprehensive Approaches

Comprehensive planning approaches that integrate transmission, distribution, generation and system performance goals, from distribution to bulk power system across an entire network, greatly facilitate and reduce the

International Journal of Innovative Research in Science, Engineering and Technology

(A High Impact Factor, Monthly, Peer Reviewed Journal)

Visit: www.ijirset.com

Vol. 8, Issue 11, November 2019

implementation costs of variable renewable energy integration. The coordination and integration of planning processes helps regulators prepare for the potential impacts that variable generation may have on the system and evaluate the available options to optimize generation and transmission costs. Planning processes that integrate multiple jurisdictions facilitate transmission expansions and the geographic distribution of renewable energy sources. Integrating local and regional planning efforts helps promote the cooperation or enlargement of balancing authorities, diversifies demand and supply and eases the integration of higher levels of variable renewable energy generation. Resource planning takes many different forms around the world. However, the experience in different countries shows that there are a few practices that can be applied in many different regulatory contexts. Three key principles that have been identified include:

1. Integrating the planning of generation, transmission, and system performance
2. Ensuring institutions and markets are designed to enable access to physical capacity
3. Building from local and regional planning to better integrate and coordinate information across jurisdictions.

Planning processes that optimize generation, transmission and other resources across an entire network greatly reduce the need and cost of variability mitigation mechanisms.

b. Operation Planning

Under the increased variability and uncertainty due to PV and wind generation penetration, in order to preserve reliability in an economic way, it is crucial to improve the predictability and flexibility in the operation of a power system. Given the unit-commitment and dispatching of the conventional generators assessed in the sale/purchase session of the energy market and given the forecast of load and renewable PV and WIND, the steps of the assessment of the balancing reserve are:

- The uncertainty evaluation based on the load demand, the wind and solar power generation and the forced outage risk of thermal units;
- The probabilistic combination of the above mentioned uncertainties and the consequential evaluation on the needed balancing reserve to match the demand for a given confidence level.

c. Augmentation Planning

In the last few decades, the increasing penetration of variable generation technologies most notably wind and solar has required changes in the way the electricity grid is operated. The daily and seasonal variability patterns observed in wind and solar technologies present a challenge to their efficient integration into existing electrical grids. Given the complexity of modern grids, it is necessary to employ computational simulation models to fully understand the effects of introducing increasing variable generation levels, devise effective mechanisms that facilitate their integration, and optimize costs.

The design and complexity of the optimal variable generation integration model will depend on the goals of each study, as well as the levels of added solar PV capacity. Some of the study components presented in this section may be omitted for studies looking at shorter time horizons, or relatively low levels of increased solar PV penetration, for example. Before designing a solar PV integration study it's important to consider its main goals. Examples include:

- Evaluating the costs of integrating variable renewable energy source into the system
- Identifying variable renewable energy integration impacts on grid operation

Measuring the amount of variable renewable energy the existing system can absorb before changes in operation or physical configuration are needed.

VII. RESEARCH THE LOCAL LOAD SITUATION

The Singrauli power grid is divided into four areas. According to the statistical data in 2017, summer peak load reached 16,500 kW, and winter peak load reached 18,000 kW. The power supply ability is 13,000 kW in summer, and 10,200 kW in winter; shortage of electricity is a very serious issue. The hydro/PV hybrid power system structure is shown in

International Journal of Innovative Research in Science, Engineering and Technology

(A High Impact Factor, Monthly, Peer Reviewed Journal)

Visit: www.ijirset.com

Vol. 8, Issue 11, November 2019

Figure 3. The PV station is composed of 40 branches of 50 kWp PV systems. The total capacity of the PV module is 2 MWp. In each branch, there is a 760 kWh battery bank integrated into a DC bus, and the total capacity of the battery is 15.2 MWh. The PV station consists of three PV units, including a power controllable unit, two dual-mode PV units, and a self-synchronous PV unit. In normal operation, hydropower plants support the power grid, and the PV power system outputs active power and reactive power in accordance with the requirement of the scheduling institute. When the grid is down, the two dual-mode PV units support the grid alone.

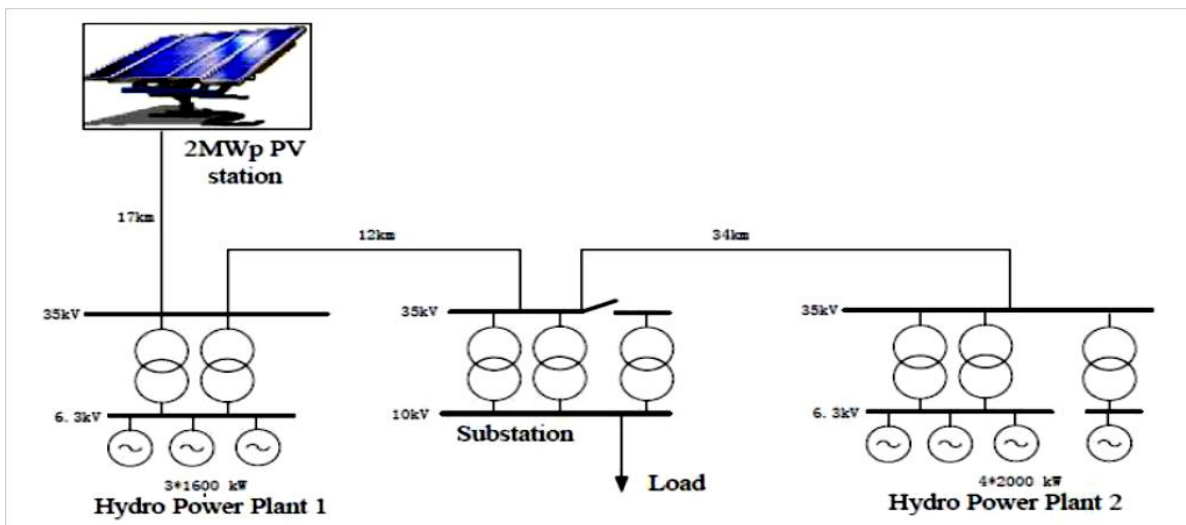

Fig.3 Hydro/photovoltaic hybrid power system

VIII. ISSUES AND SOLUTION FOR PV PENETRATION

The PV penetration of the hydro/PV hybrid power system is about 17%. The control strategy of the hybrid power system as follows: In daytime, the hydropower plants support the power grid operation; the electricity generated by the PV power station will be stored in the battery. In the peak load time in the evening, both the hydropower plants and the PV power station supply power to the grid as instructed. When power is insufficient, the load is reduced. Thus, through energy storage, the impact of PV fluctuation is decreased. For this purpose, the central management system given the forecasts for load and RES availability and the state of charge of the battery system should be able to make a prediction of short term RES production and system demand, providing appropriate signals for the management of power production and of the controllable loads.

IX. LOAD FORECASTING FOR POWER SYSTEM PLANNING USING ANFIS

Load forecasting has been an integral part in the efficient planning, operation and maintenance of a power system. Short term load forecasting is necessary for the control and scheduling operations of a power system and also acts as inputs to the power analysis functions such as load flow and contingency analysis. Owing to this importance, various methods have been reported, that includes linear regression, exponential smoothing, stochastic process, ARMA models, and data mining models. Of late, artificial neural networks have been widely employed for load forecasting. However, there exist large forecast errors using ANN when there are rapid fluctuations in load and temperatures. In such cases, forecasting methods using fuzzy logic approach have been employed. In this paper, an approach for long term load forecasting problem, using ANFIS approach is proposed. The fuzzy logic technique has been used to classify the data's. The neural network is used to calculate the increment factor of load due to other parameters like growth in industries, increase in number of customers etc.

International Journal of Innovative Research in Science, Engineering and Technology

(A High Impact Factor, Monthly, Peer Reviewed Journal)

Visit: www.ijirset.com

Vol. 8, Issue 11, November 2019

9.1 Adaptive Neuro-Fuzzy Method

Adaptive neuro-fuzzy method (or Adaptive neuro-fuzzy inference system, ANFIS) has become a popular method in control area. In this section, we give a brief description of the principles of Adaptive neuro-fuzzy inference system (ANFIS). The basic structure of the type of fuzzy inference system could be seen as a model that maps input characteristics to input membership functions. Then it maps input membership function to rules and rules to a set of output characteristics. Finally it maps output characteristics to output membership functions, and the output membership function to a single valued output or a decision associated with the output. It has been considered only fixed membership functions that were chosen arbitrarily. Fuzzy inference is only applied to only modeling systems whose rule structure is essentially predetermined by the user's interpretation of the characteristics of the variables in the model. However, in some modeling situations, it cannot distinguish what the membership functions should look like simply from looking at data. Rather than choosing the parameters associated with a given membership function arbitrarily, these parameters could be chosen so as to tailor the membership functions to the input/output data in order to account for these types of variations in the data values. In such case the necessity of the adaptive neuro fuzzy inference system becomes obvious. The parameters associated with the membership functions changes through the learning process. The computation of these parameters (or their adjustment) is facilitated by a gradient vector. This gradient vector provides a measure of how well the fuzzy inference system is modeling the input/output data for a given set of parameters. When the gradient vector is obtained, any of several optimization routines can be applied in order to adjust the parameters to reduce some error measure (performance index). This error measure is usually defined by the sum of the squared difference between actual and desired outputs. ANFIS uses a combination of least squares estimation and back propagation for membership function parameter estimation. Fig.4 shows Sugeno's fuzzy logic model. Fig.5 shows the architecture of the ANFIS, comprising by input, fuzzification, inference and defuzzification layers. The network can be visualized as consisting of inputs, with N neurons in the input layer and F input membership functions for each input, with F*N neurons in the fuzzification layer. There are FN rules with FN neurons in the inference and defuzzification layers and one neuron in the output layer. For simplicity, it is assumed that the fuzzy inference system under consideration has two inputs x and y and one output z as shown in Fig.5. For a zero-order Sugeno fuzzy model, a common rule set with two fuzzy if-then rules is the following:

Rule 1: If x is A_1 and y is B_1 , Then $f_1 = r_1$

Rule 2: If x is A_2 and y is B_2 , Then $f_2 = r_2$

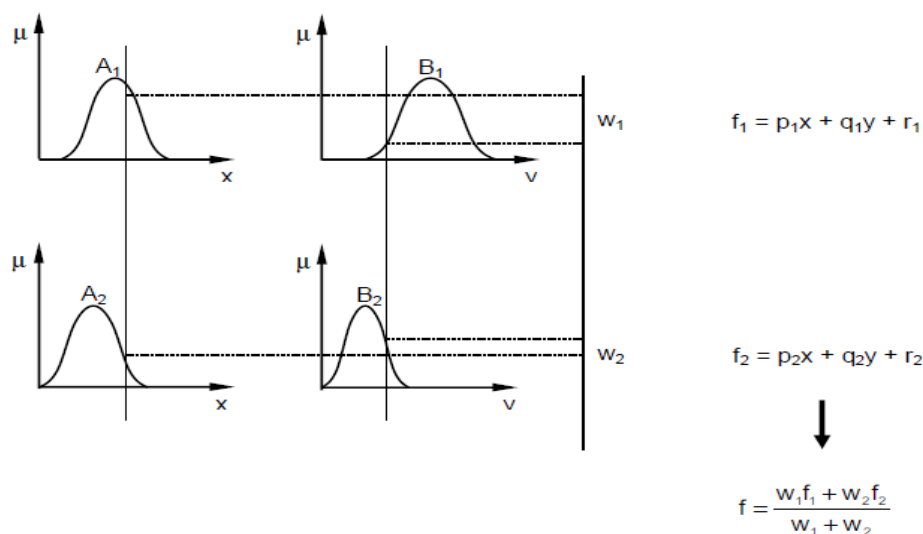

Fig.4 Sugeno's fuzzy logic model

International Journal of Innovative Research in Science, Engineering and Technology

(A High Impact Factor, Monthly, Peer Reviewed Journal)

Visit: www.ijirset.com

Vol. 8, Issue 11, November 2019

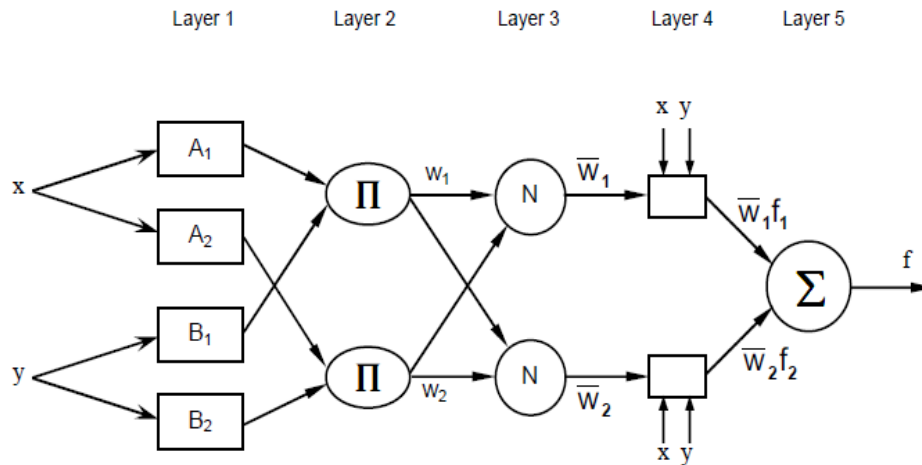

Fig.5 The architecture of the ANFIS

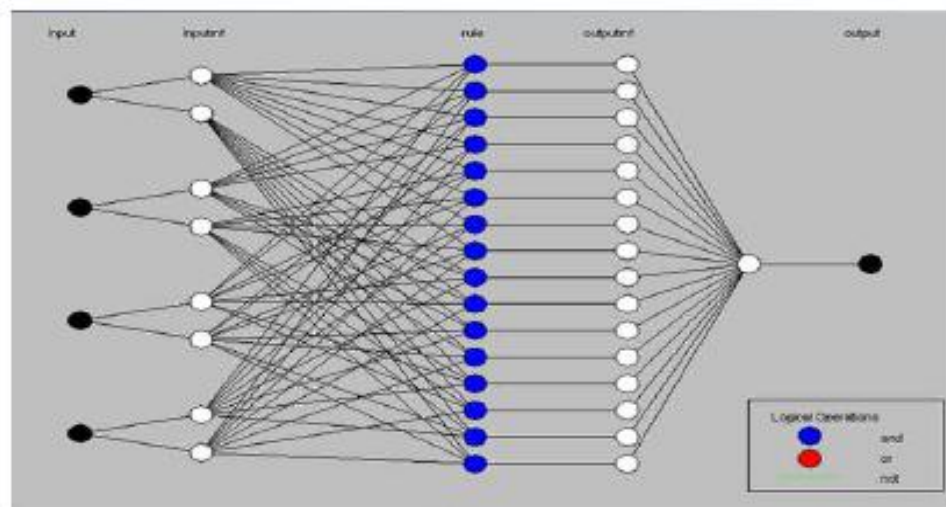

Fig.6 Structure of Sugeno type ANFIS

Here the output of the i^{th} node in layer n is denoted as $O_{n,i}$:

Layer 1. Every node i in this layer is a square node with a node function:

$$O_i^1 = \mu_{A_i}(x), \quad \text{for } i = 1,2$$

$$O_i^1 = \mu_{B_{i-2}}(y), \quad \text{for } i = 3,4$$

where x is the input to node- i , and A_i is the linguistic label (*small*, *large*, etc.) associated with this node function. In other words, O_i^1 is the membership function of A_i and it specifies the degree to which the given x satisfies the quantifier A_i . Usually $\mu_{A_i}(x)$ is chosen to be bell-shaped with maximum equal to 1 and minimum equal to 0, such as the generalized bell function

$$\mu_A(x) = \frac{1}{1 + \left[\frac{x - c_i}{a_i} \right]^{2b_i}}$$

International Journal of Innovative Research in Science, Engineering and Technology

(A High Impact Factor, Monthly, Peer Reviewed Journal)

Visit: www.ijirset.com

Vol. 8, Issue 11, November 2019

Parameters in this layer are referred to as *premise parameters*.

Layer 2. Every node in this layer is a circle node labeled Π which multiplies the incoming signals and sends the product out. For instance,

$$O_i^2 = w_i = \mu_{A_i}(x) \cdot \mu_{B_i}(y), \quad i = 1,2$$

Each node output represents the firing strength of a rule. (In fact, other *T-norm* operators that performs generalized AND can be used as the node function in this layer.)

Layer 3. Every node in this layer is a circle node labeled N . The i^{th} node calculates the ratio of the i^{th} rule's firing strength to the sum of all rules firing strengths:

$$O_i^3 = \bar{w} = \frac{w_i}{w_1 + w_2}, \quad i = 1,2$$

For convenience, outputs of this layer will be called *normalized firing strengths*.

Layer 4. Every node i in this layer is a square node with a node function:

$$O_i^4 = \bar{w}_i f_i = \bar{w}_i (p_i x + q_i y + r_i)$$

where \bar{w}_i is the output of layer 3, and $\{p_i, q_i, r_i\}$ is the parameter set. Parameters in this layer will be referred to as *consequent parameters*.

Layer 5. The single node in this layer is a circle node labeled Σ that computes the overall output as the summation of all incoming signals, i.e.,

$$O_i^5 = \sum \bar{w}_i f_i$$

X. SIMULATION

The simulation environment based on MATLAB software package is selected. It is used as the main engineering tool for performing modeling and simulation of hybrid power systems, as well as for interfacing the user and appropriate simulation programs. The figure 7 shows the variation of load for the year 2014, 2015 and 2016 for a particular region. It also gives the variation of temperature and humidity at the bottom.

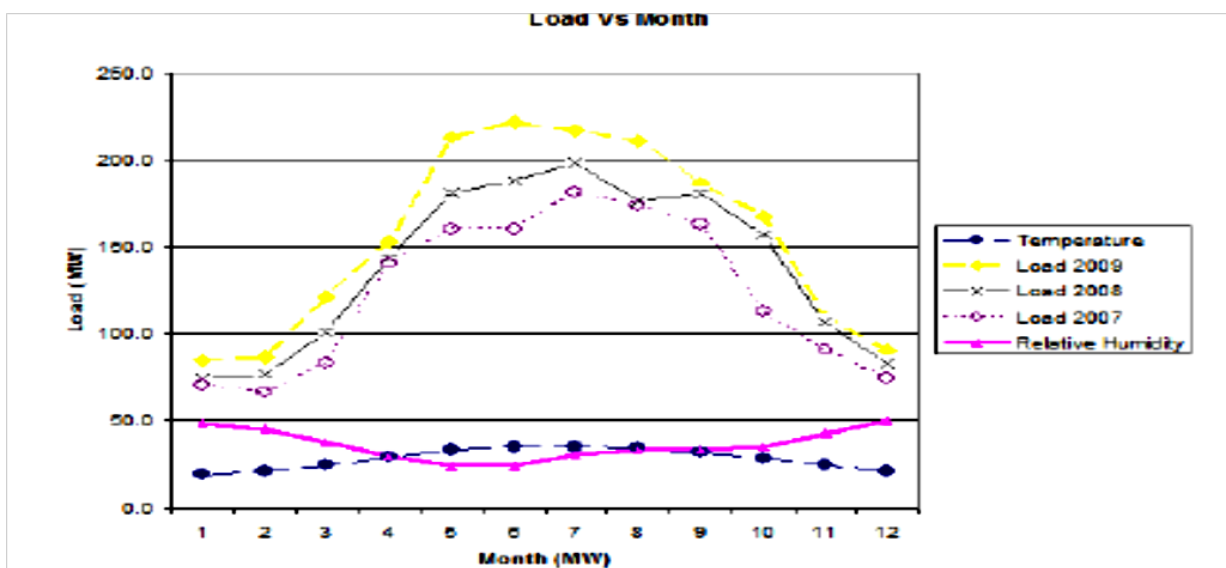

Fig.7. Load Vs Temperature, Humidity and Load Curve

International Journal of Innovative Research in Science, Engineering and Technology

(A High Impact Factor, Monthly, Peer Reviewed Journal)

Visit: www.ijirset.com

Vol. 8, Issue 11, November 2019

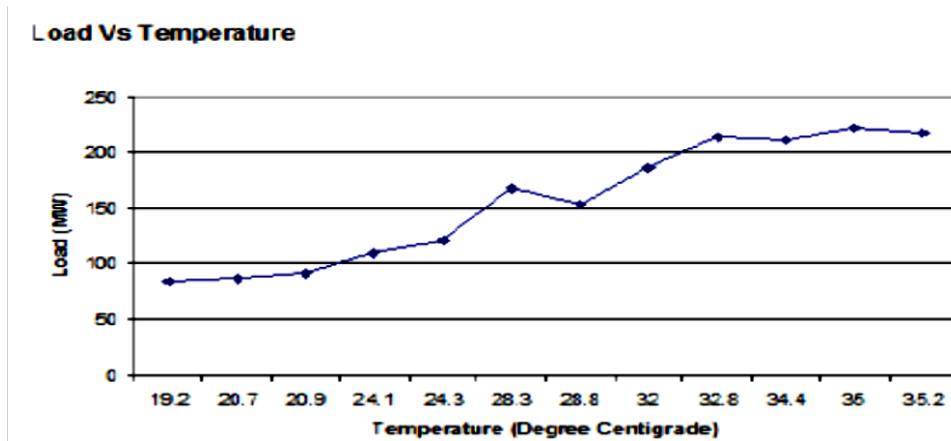

Fig.8.Load Vs Temperature

To make a detailed analysis figure 8 shows that the load increase linearly with the increase in temperature and the figure 9 shows that the load decreases with increase in humidity. Hence it is clear that the maximum temperature has low humidity and hence the load is maximum. It has also been observed that the minimum temperature has maximum humidity and the load is minimum. There is an intersection point as where the load is medium. These data's are fed to the Fuzzy system for classifying the data and to get the output

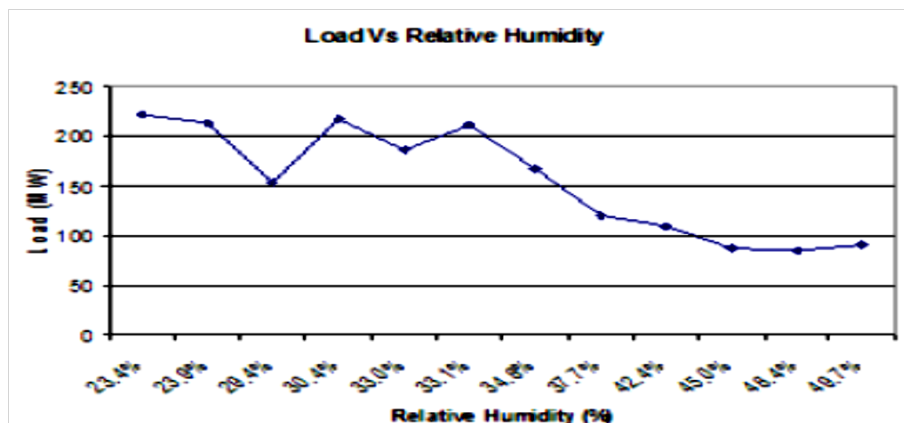

Fig.9 Load Vs Humidity

International Journal of Innovative Research in Science, Engineering and Technology

(A High Impact Factor, Monthly, Peer Reviewed Journal)

Visit: www.ijirset.com

Vol. 8, Issue 11, November 2019

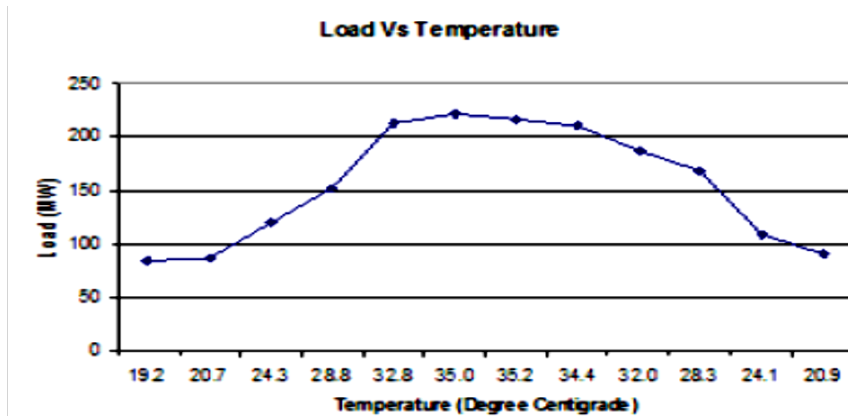

Fig.10 Load Vs Temperature

A. Fuzzification of Input and the Outputs

In this paper the load is classified as very Low, Low, Medium and High Load. It is seen from the figure 9 and 10 that the load falls between 50 and 250 MW. From the graph it is clearly seen that the data can be classified as (50-100), (100-150), (150-200) and (200-250). The corresponding

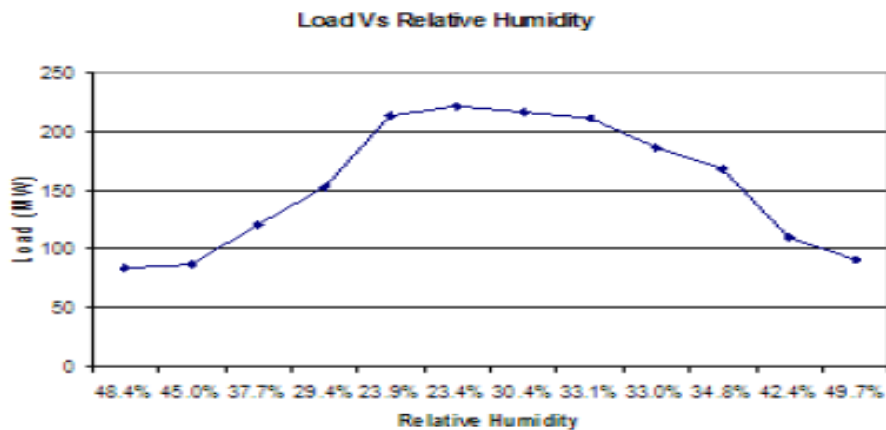

Fig.11 Load Vs Humidity

TABLE I
CLASSIFICATION OF TEMPERATURE, HUMIDITY WITH RESPECT TO THE LOAD FOR FUZZIFICATION AND DEFUZZIFICATION

Load	50-100	100-150	150-200	200-250
Temperature	18.2, 19.7, 19.9	23.3, 23.1	27.7, 31, 27.3	31.8, 34, 34.2, 33.3
Humidity	47.4, 44, 48.6	36.7, 28.3, 41.4	33.8, 32, 28.4	22.9, 22.3, 29.4, 32.3
Range for Fuzzification				
Classification	Very Low	Low	Medium	High
Temperature	18-20	23-26	27-31	31-35
Humidity	44-49	29-41		22-32

International Journal of Innovative Research in Science, Engineering and Technology

(A High Impact Factor, Monthly, Peer Reviewed Journal)

Visit: www.ijirset.com

Vol. 8, Issue 11, November 2019

temperature and humidity can be seen from the x-axis, which are used to classify the humidity and temperature ranges for fuzzification. The Table I shows how the temperature and humidity can be classified according to the load. As mentioned for the various classification of load the corresponding temperature and humidity are taken. Then the ranges of fuzzification are obtained as shown in the second part of the table. The figure 12 and 13 shows how the inputs are classified for fuzzification. It is observed that the temperatures are classified with the ranges (20-24), (23-27), (26-32), (31-40) as Very Low, Low, Medium and high respectively. The humidity is classified as (20-33), (30-42), (40-50) as Low, Medium and High respectively.

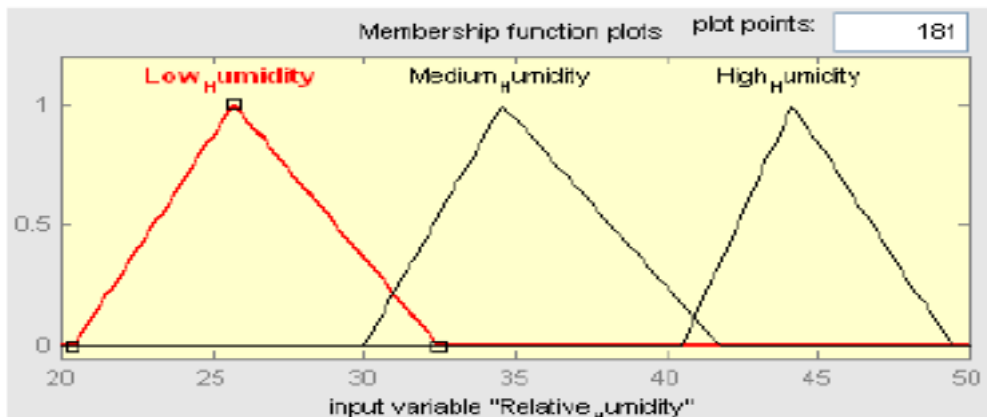

Fig.12 Membership function for Relative Humidity

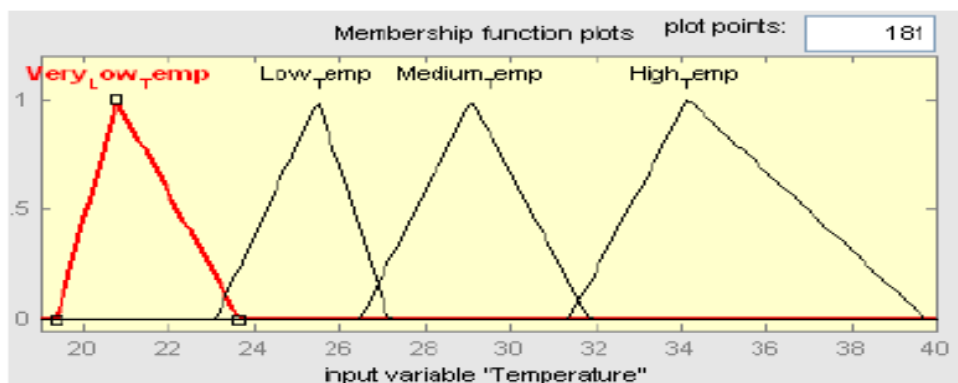

Fig.13 Membership function for Temperature

For example it is seen that the high temperature and low humidity gives an output of high load, similarly for low temperature and high humidity the output is Very Low Load. This can be cross checked with the actual load in table II which shows that the load is 210MW which is very close to the actual value.

International Journal of Innovative Research in Science, Engineering and Technology

(A High Impact Factor, Monthly, Peer Reviewed Journal)

Visit: www.ijirset.com

Vol. 8, Issue 11, November 2019

TABLE II
TEMPERATURE, HUMIDITY VS ACTUAL/PREDICTED LOAD

Temperature	Relative Humidity	Predicted Load	Actual Load	Error	Future Load
18.2	47.4	77	83.34	6.50	127.5
19.7	44	74	85.5	12.5	130.1
23.1	36.4	121	119.4	1.0	164.2
27.6	28.4	171	151.3	11.43	106.1
31.2	22.3	221	212.1	3.56	256.6
34	22.4	222	221.4	0.34	264.3
34.2	29.4	223	215.5	3.37	260
33.3	32.1	220	219.6	3.87	254.1
31	32	171	165.3	2.10	210.2

Table-1 shows the relationship between the temperatures, relative humidity with the future load. It can be seen that the increase in temperature values will lead to the increase of load values. It is noticeable that the increase in relative humidity will result in the decrease of load values. Also, it can also be seen that the combination of minimum temperature with maximum humidity will obtain minimum load value.

XI. MODELLING AND DEVELOPMENT OF ANFIS BASED SHORT-TERM LOAD FORECASTING SYSTEM

The first and most important task for designing a system for one day ahead load forecasting is the identification of input parameters. Six unique inputs are used in this research work: (1) Hour number (2) Month number (3) Day of the week (4) Maximum temperature (5) Minimum temperature (6) Previous day load of same hour One year load-demand data along with the maximum and minimum temperature data of each day has been employed for the training of the ANFIS to predict the 24-hour load. The structure of the proposed ANFIS based forecasting system is shown in Figure 14. Figure 15 shows the ANFIS editor after loading input and target data.

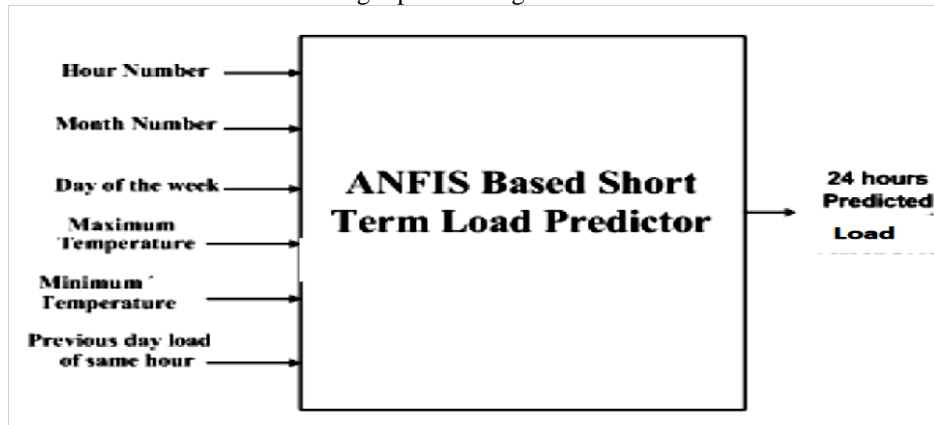

Fig.14 Structure of ANFIS based short term load forecasting system

International Journal of Innovative Research in Science, Engineering and Technology

(A High Impact Factor, Monthly, Peer Reviewed Journal)

Visit: www.ijirset.com

Vol. 8, Issue 11, November 2019

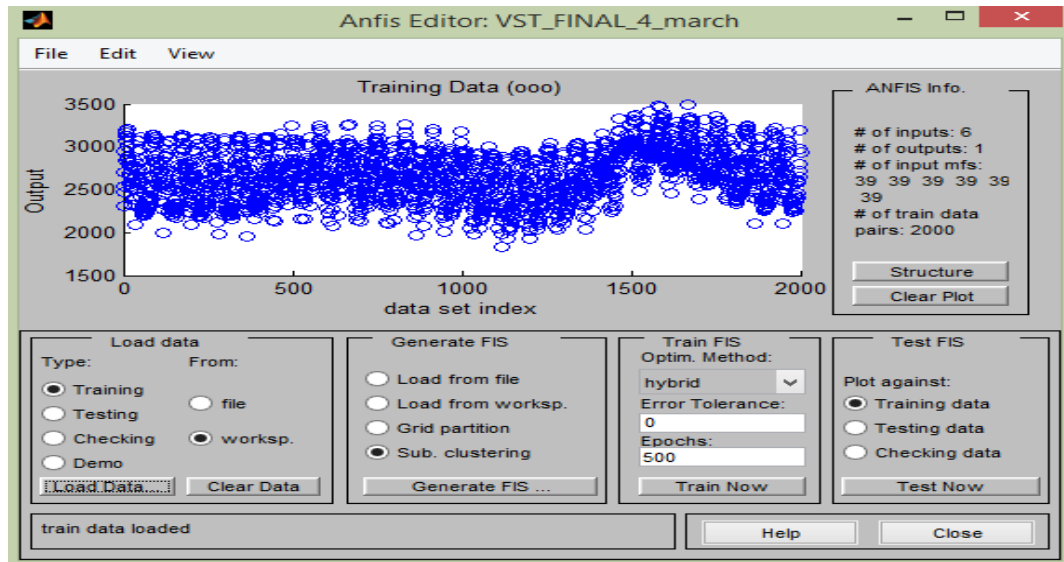

Fig.15 ANFIS editor after loading input and target data

Figure 16 shows the training process of proposed ANFIS predictor. The training error achieved is 33.1305

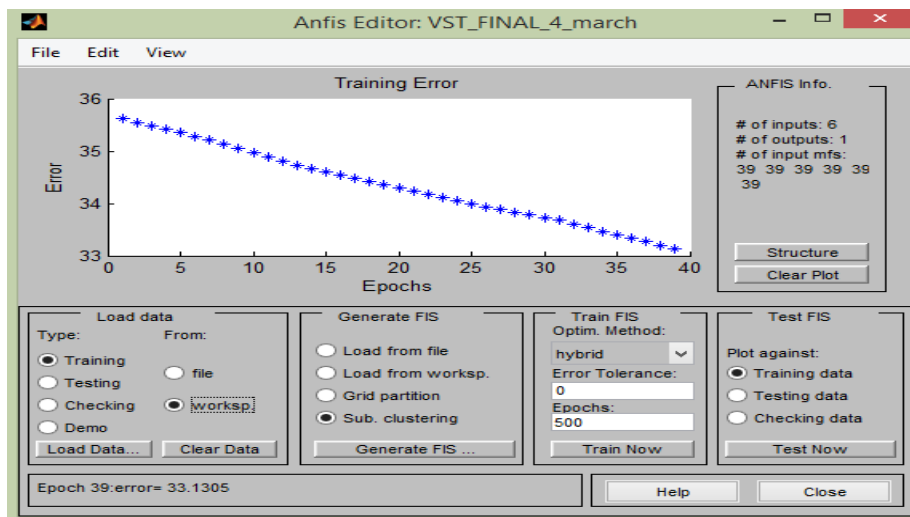

Fig.16 Training process for proposed ANFIS predictor

International Journal of Innovative Research in Science, Engineering and Technology

(A High Impact Factor, Monthly, Peer Reviewed Journal)

Visit: www.ijirset.com

Vol. 8, Issue 11, November 2019

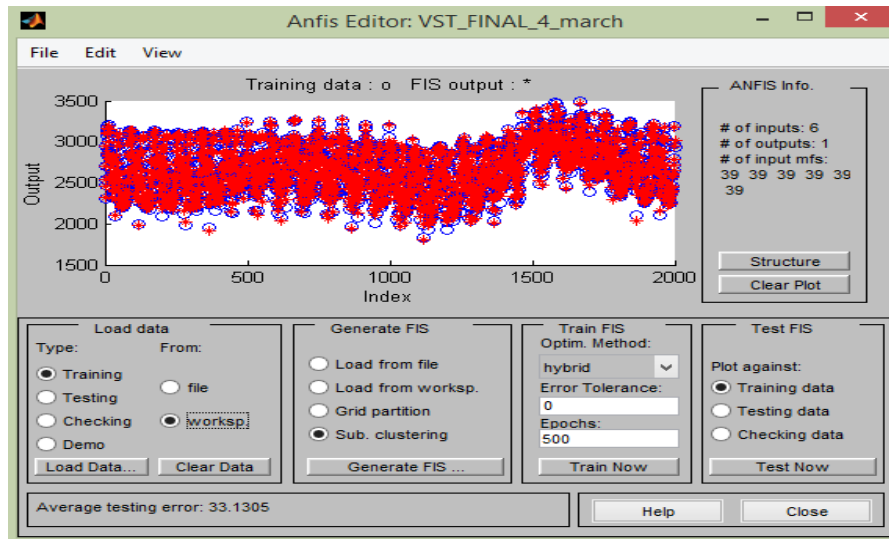

Fig.17 Testing process for proposed ANFIS predictor

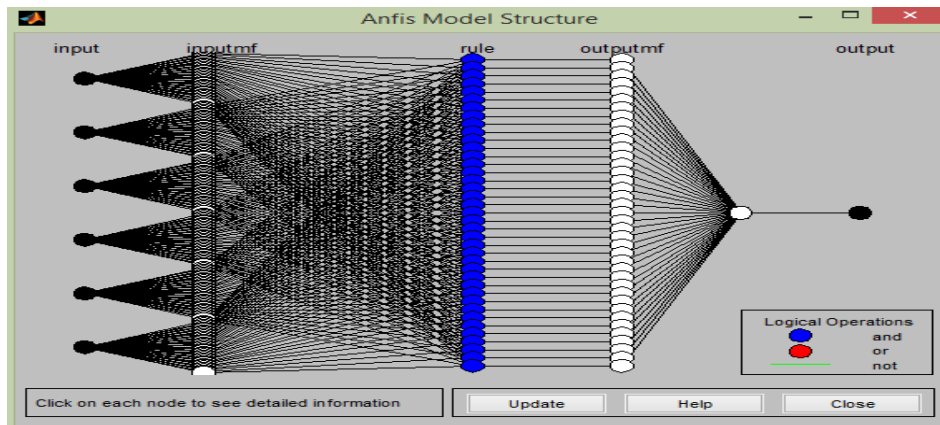

Fig.18 Structure of developed ANFIS predictor

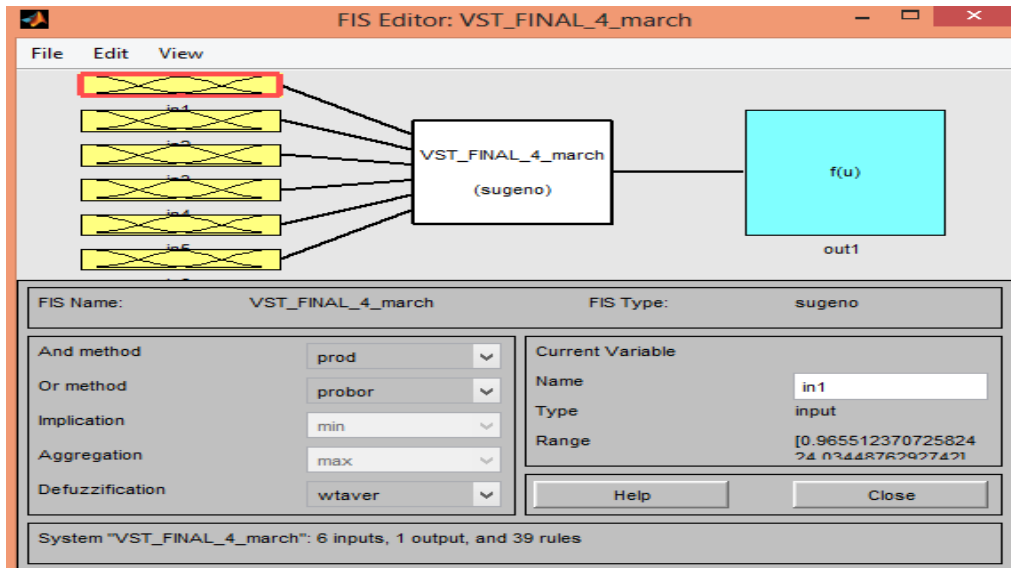

Fig.19 Layout of developed ANFIS predictor

XII. RESULT DISCUSSION

The graphical representation of the comparison between the desired weekly load values and the ANFIS predicted values is presented in Fig.20. Results clearly show the excellent training as well as prediction performance. The training error; checking error and the step-size progress are illustrated in Fig.21 and 22. The initial step size is defined to 0.01. The step size decrease rate is 1.5 and the step size increase rate is 2.5. The training error goal is set to 0.

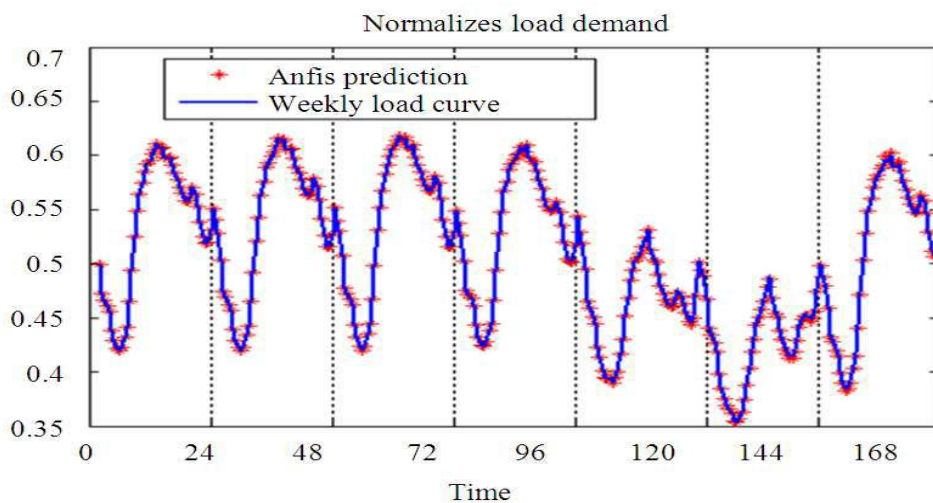

Fig. 20: Comparison of load series within a week

International Journal of Innovative Research in Science, Engineering and Technology

(A High Impact Factor, Monthly, Peer Reviewed Journal)

Visit: www.ijirset.com

Vol. 8, Issue 11, November 2019

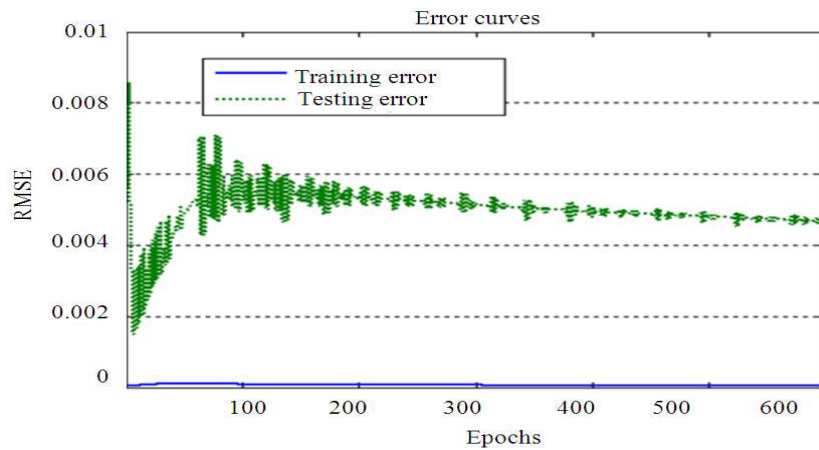

Fig. 21: Comparing the training and checking error realized and predicted

The model developed was tested several times using different number of rules and membership functions. Finally the best results are obtained by four bell shaped membership functions and sixteen rules. The performance of the forecast model was evaluated and the results are as shown in Fig.22 and 23 for 1 day and 3 day respectively.

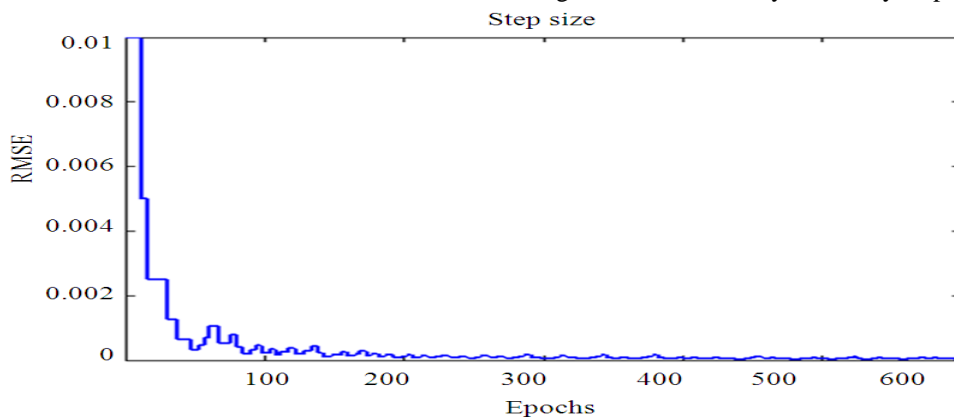

Fig.22: Step sizes

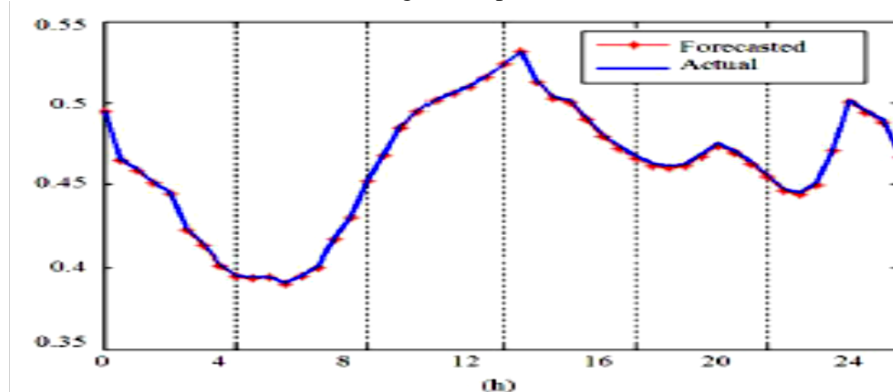

Fig.23: Load forecasted for 1 day (48 points)

International Journal of Innovative Research in Science, Engineering and Technology

(A High Impact Factor, Monthly, Peer Reviewed Journal)

Visit: www.ijirset.com

Vol. 8, Issue 11, November 2019

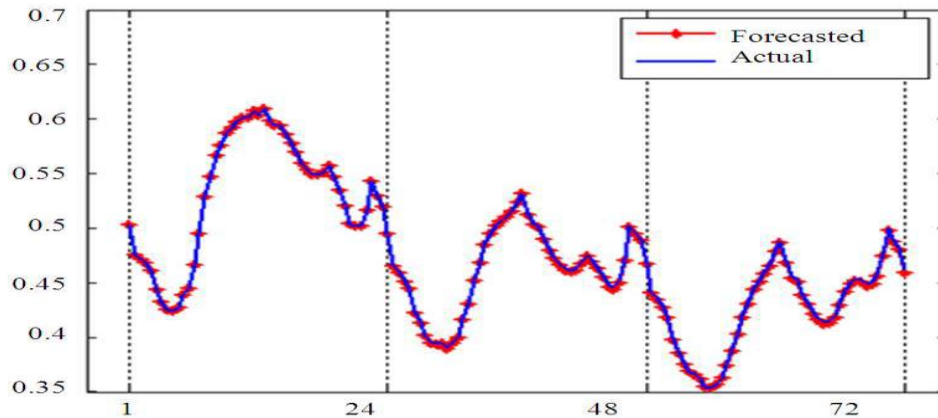

Fig.24 Load forecasted for 3 day (144 points)

The parameters of the system for next half hour load forecasting are as mentioned in Table 2. Short-Term Load Forecasting of PV Grid is performed successfully by using the data obtained from State Load Dispatch Centre of Power Transmission Company Limited. ANFIS is used in MATLAB 2013 (a) to train and test the data obtained from power company. The hourly load forecast of is obtained by using the load-demand data of PV grid and the temperature data of same time period. Table 1 shows the actual load obtained from power company and the forecasted load using ANFIS based prediction system along with the prediction error.

Table 1: ANFIS Load forecasting results

Hour No.	Actual Load in MW	Forecasted Load By ANFIS in MW	Difference in MW	Percent Prediction Error
1	2487	2453.253	33.747	1.357
2	2472	2429.380	42.620	1.724
3	2491	2511.385	20.385	0.818
4	2518	2533.705	15.705	0.624
5	2523	2585.605	62.605	2.481
6	2637	2674.409	37.409	1.419
7	2761	2736.153	24.847	0.900
8	2791	2802.240	11.240	0.403
9	2727	2692.690	34.310	1.258
10	2642	2601.173	40.827	1.545
11	2702	2725.986	23.986	0.888
12	2638	2610.278	27.722	1.051
13	2454	2433.480	20.520	0.836
14	2458	2503.381	45.381	1.846
15	2453	2496.118	43.118	1.758
16	2581	2527.571	53.429	2.070
17	2693	2662.112	30.888	1.147
18	2936	2904.499	31.501	1.073
19	3355	3338.972	16.028	0.478
20	3166	3193.731	27.731	0.876
21	3145	3166.986	21.986	0.699
22	2935	2971.010	36.010	1.227
23	2857	2932.375	75.375	2.638
24	2869	2884.263	15.263	0.532
Average Percentage Prediction Error for 24 Hours in MW				1.235

International Journal of Innovative Research in Science, Engineering and Technology

(A High Impact Factor, Monthly, Peer Reviewed Journal)

Visit: www.ijirset.com

Vol. 8, Issue 11, November 2019

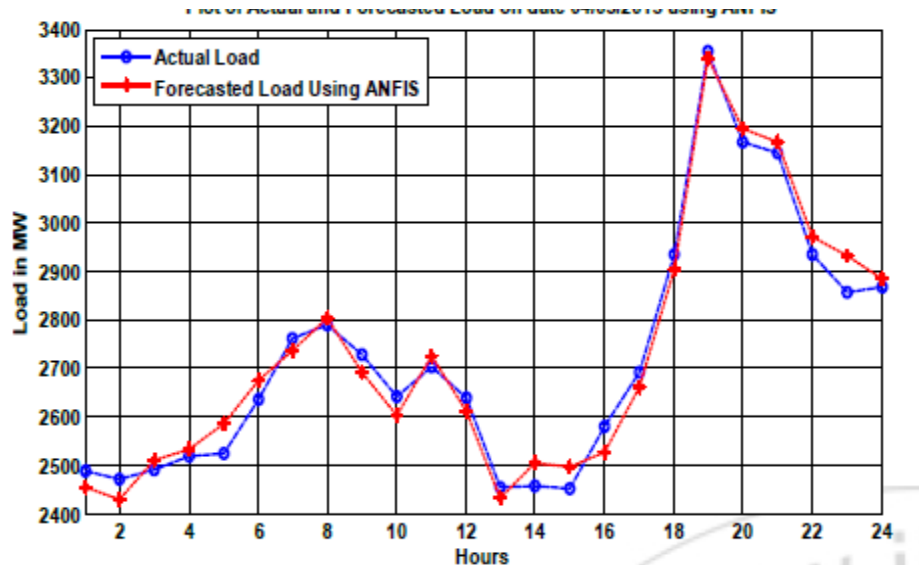

Fig. 25 Plot of Actual load and Forecasted load obtained by using ANFIS in MATLAB

The load forecast obtained from ANFIS method is compared with the actual load of the same day obtained as shown in Figure 25. The Average Prediction Error of 1.235 % is obtained which is very low and it shows the high prediction accuracy of ANFIS used for short-term load forecasting.

XIII. CONCLUSIONS

The system analysis, simulation and comparison with historic electricity production data show that the implementation of a RES based power system for the community is cost effective, with a total electricity cost over a system lifetime of 25 years, of less than half of the conventional diesel fuel powered system. The design of the new system has to take into account the reliability issues of the most important components in order to avoid lengthy disruption in the main mode of RES operation of the microgrid and avoid the use of diesel fuel. The backbone for the operation of the microgrid is the Central Supervisory Control and Data Acquisition system for the overall automatic and uninterruptible switch between modes operation of the microgrid. It should be reliable in order to have an effective microgrid operation. In this paper a methodology for long term PV system load forecasting using ANFIS approach is presented. A new temperature and humidity relationship with load is obtained. The ANFIS is used to obtain the variation of load and a correction factor is derived from an artificial neural network back propagation algorithm to predict the future load. It has been observed that the variation of predicted load from actual load has an average percentage error of 7.8%. The load forecast obtained from ANFIS method is compared with the actual load of the same day obtained. The Average Prediction Error of 1.235 % is obtained which is very low and it shows the high prediction accuracy of ANFIS used for short-term load forecasting.

REFERENCES

1. S. Surender Reddy and James A. Momoh, "Short Term Electrical Load Forecasting Using Back Propagation Neural Networks", *IEEE Transactions on Power Systems*, 2014, pp. 1-6.
2. R.C. Bansal, R.K. Saket and A.K. Srivastav, "Electric Power Demand Forecasting of Kaval Cities", *International Journal of Electric and Power Engineering*, 2010, Vol. 4, Issue 2, pp. 85-89.
3. Mohan B. Tasre, Vilas N. Ghate, Prashant P. Bedekar, "Comparative Analysis of Hourly Load Forecast for a Small Load Area", *IEEE and International Conference on Computing, Electronics and Electrical Technologies*, 2012, pp. 1-6.
4. K. Metaxiotis, A. Kagiannas, D. Askounis, J. Psarras, "Artificial intelligence in short term electric load forecasting: a state-of-the-art survey for the research", *Energy Conversion and Management* 44, 2003, pp.1525-1534.

International Journal of Innovative Research in Science, Engineering and Technology

(A High Impact Factor, Monthly, Peer Reviewed Journal)

Visit: www.ijirset.com

Vol. 8, Issue 11, November 2019

5. Tomonoobu senjyu, hitoshi takara, katsumi ueezato, toshihisa funabashi, "One-hour ahead load forecasting using neural network", *IEEE Trans. power syst.*, vol.17, no.1, February 2002, pp.113-118.
6. Mohsen Hayati, Yazdan Shirvany, "Artificial neural network approach for short term load forecasting for Illam region", *International journal of electrical, computer, and system engineering*, vol.1, no.2, pp.121-125.
7. Mohanty, S., Patra, P.K., Sahoo, S.S. and Mohanty, A., 2017. Forecasting of solar energy with application for a growing economy like India: Survey and implication. *Renewable and Sustainable Energy Reviews*, 78, pp.539-553.
8. Mellit, A., Arab, A.H. and Shaari, S., 2007. An ANFIS - based prediction for monthly clearness index and daily solar radiation: application for sizing of a stand-alone Photovoltaic system. *Journal of Physical Science*, 18(2), pp.15-35.
9. Mohanty, S., 2014. ANFIS based prediction of monthly average global solar radiation over Bhubaneswar (State of Odisha). *Int J Ethics Eng Manage Educ ISSN*, 1(5), pp.2348-4748.
10. Yadav, A.K. and Chandel, S.S., 2014. Solar radiation prediction using Artificial Neural Network techniques: A review. *Renewable and Sustainable Energy Reviews*, 33, pp.772-781.
11. Mohanty, S., Patra, P.K. and Sahoo, S.S., 2015, December. Prediction of global solar radiation using nonlinear auto regressive network with exogenous inputs (narx). In *Systems Conference (NSC), 2015 39th National* (pp. 1-6). IEEE.
12. Varzandeh, M.H.M., Rahbari, O., Vafaeipour, M., Raahemifar, K. and Heidarzade, F., 2014. Performance of Wavelet Neural Network and ANFIS Algorithms for Short-Term Prediction of Solar Radiation and Wind Velocities. In *The 4th World Sustainability Forum*.
13. Ramedani, Z., Omid, M. and Keyhani, A., 2013. Modeling solar energy potential in a Tehran Province using artificial neural networks. *International Journal of Green Energy*, 10(4), pp.427-441.
14. Rahoma, W.A., Rahoma, U.A. and Hassan, A.H., 2011. Application of neuro-fuzzy techniques for solar radiation.
15. Iqdour, R. and Zeroual, A., 2006. A rule based fuzzy model for the prediction of solar radiation. *Revue des energies renouvelables*, 9(2), pp.113-120.
16. Sumithira, T.R., Kumar, A.N. and Kumar, R.R., 2012. An adaptive neuro-fuzzy inference system () based Prediction of Solar Radiation: A Case study. *Journal of Applied Sciences Research*, 8(1), pp.346-351. ANFIS
17. Yadav, A.K. and Chandel, S.S., 2015. Solar energy potential assessment of western Himalayan Indian state of Himachal Pradesh using J48 algorithm of WEKA in based prediction model. *Renewable Energy*, 75, pp.675- 693. ANN
18. Bhardwaj, S., Sharma, V., Srivastava, S., Sastry, O.S., Bandyopadhyay, B., Chandel, S.S. and Gupta, J.R.P., 2013. Estimation of solar radiation using a combination of Hidden Markov Model and generalized Fuzzy model. *Solar Energy*, 93, pp.43-54.
19. Mohammadi, K., Shamsirband, S., Petković, D. and Khorasanizadeh, H., 2016. Determining the most important variables for diffuse solar radiation prediction using adaptive neuro-fuzzy methodology; case study: City of Kerman, Iran. *Renewable and Sustainable Energy Reviews*, 53, pp.1570-1579.
20. Mohanty, S., Patra, P.K. and Sahoo, S.S., 2015. Comparison and prediction of monthly average solar radiation data using soft computing approach for Eastern India. In *Computational Intelligence in Data Mining- Volume 3* (pp. 317-326). Springer, New Delhi.
21. Jafarkazemi, F., Moadel, M., Khademi, M. and Razeghi, A., 2013. Performance prediction of flat-plate solar collectors using MLP and ANFIS . *Journal of Basic and Applied Scientific Research*, 3(2), pp.196-200.