

# **Spectrum Efficiency and BER Analysis of Massive MIMO Systems with QR-RLS and QAM Modulation Technique**

Nivesh Dwivedi<sup>1</sup>, Prof. Balram Yadav<sup>2</sup>

M. Tech. Scholar, Department of Electronics and Communication, Scope College of Engineering, Bhopal, India<sup>1</sup>

Professor, Department of Electronics and Communication, Scope College of Engineering, Bhopal, India<sup>2</sup>

**ABSTRACT:** The fifth generation of mobile communication systems (5G) promises unprecedented levels of connectivity and quality of service (QoS) to satisfy the incessant growth in the number of mobile smart devices and the huge increase in data demand. One of the primary ways 5G network technology will be accomplished is through network densification, namely increasing the number of antennas per site and deploying smaller and smaller cells. Massive MIMO, where MIMO stands for multiple-input multiple-output, is widely expected to be a key enabler of 5G. This technology leverages an aggressive spatial multiplexing, from using a large number of transmitting/receiving antennas, to multiply the capacity of a wireless channel. The access points (Aps) are connected, through a fronthaul network, to a central processing unit (CPU) which is responsible for coordinating the coherent joint transmission. Such a distributed architecture provides additional macro-diversity, and the co-processing at multiple APs entirely suppresses the inter-cell interference. Depending on slow/fast channel fading conditions, several authors suggested adaptive LMS, RLS and NLMS based channel estimators, which either require statistical information of the channel or are not efficient enough in terms of performance or computations. In order to overcome the above effects, the work focuses on the QR-RLS based channel estimation method for Massive MIMO systems with different modulation scheme.

**KEYWORDS:** Massive MIMO, Channel State Information, Square Root-Recursive Least Square (QR-RLS), QAM Modulation

## **I. INTRODUCTION**

MIMO technology has been a topic of interest for the past two decades and MU-MIMO has made its way into standards such as 4G LTE and IEEE 802.11 (WiFi). Massive MIMO is a variant of MU-MIMO with the potential to offer significantly higher spectral and energy efficiencies at low computational complexities, making it one of the enabling technologies for 5G communication systems. Nowadays, wireless communication plays a central role in the industrial production process. Ubiquitous coverage, low latency, ultra-reliable communication, and resilience are key for wireless communications in a factory environment. In this respect, “cell-free” Massive MIMO, with its flexible distributed architecture, with its macro-diversity gain and inherent ability to suppress interference, is suitable to cope with the challenging industrial indoor scenario [2]. Also, a radio stripe deployment may integrate additional sensors/actuators such as temperature sensors, microphones, miniature speakers, vibration sensors, etc., and provide additional important features, e.g., fire alarm, burglar alarm, earthquake warning, indoor positioning, climate monitoring and control.

## **II. CHANNEL ESTIMATION**

In order to achieve the benefits of a large antenna array, accurate and timely acquisition of Channel State Information (CSI) is needed at the BS. The need for CSI is to process the received signal at BS as well as to design a precoder for optimal selection of a group of users who are served on the same time-frequency resources. The acquisition of CSI at the BS can be done either through feedback or channel reciprocity schemes based on Time Division Duplex (TDD) or

# International Journal of Innovative Research in Science, Engineering and Technology

(A High Impact Factor, Monthly, Peer Reviewed Journal)

Visit: [www.ijirset.com](http://www.ijirset.com)

Vol. 8, Issue 9, September 2019

Frequency Division Duplex (FDD) system. The procedure for acquiring CSI and data transmission for both systems is explained in the subsequent sections.

## Channel Estimation and Data Transmission in FDD System

In FDD system, the signals are transmitted at different frequency band for uplink and downlink transmission. Therefore, CSI for the uplink and downlink channels are not reciprocal. Hence, to generate precoding/beamforming vector for each user, BS transmits a pilot signal to all users in the cell and then all users' feedback estimated CSI of the downlink channels to the BS as shown in Fig. 1. During uplink transmission, BS needs CSI to decode the signal transmitted by the users. To detect the signal transmitted by the user, CSI is acquired by sending pilot signal in the uplink transmission.

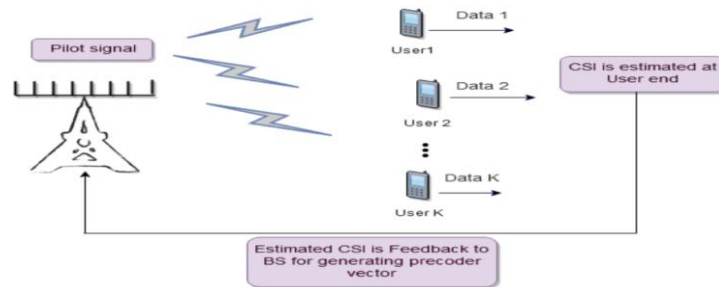

Figure 1: Downlink transmission in an FDD Massive MIMO system

## III. PROPOSED METHODOLOGY

The MIMO-OFDM device modified into applied with the useful resource of MATLAB/SIMULINK. The execution device is binary facts this is modulated the use of QAM and mapped into the constellation elements.

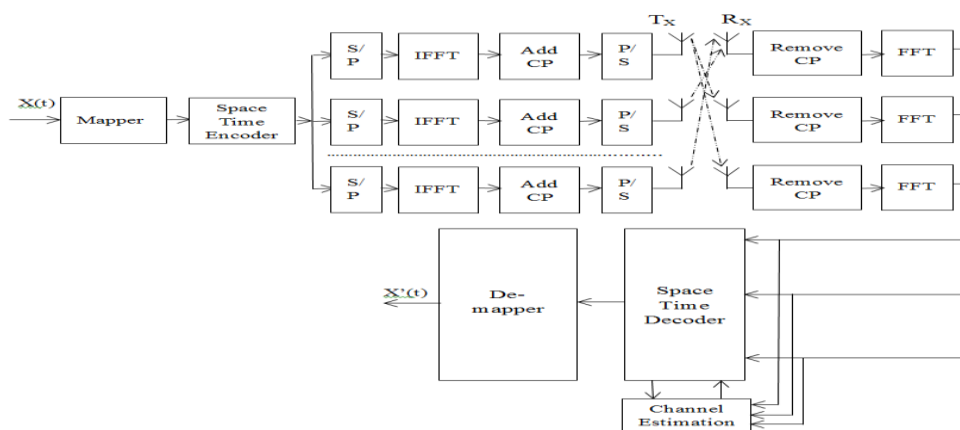

Figure 2: Massive MIMO System Models with Channel Estimation Technique

The virtual modulation scheme will transmit the records in parallel by means of manner of assigning symbols to every sub channel and the modulation scheme will determine the phase mapping of sub-channels thru a complex I-Q mapping vector show in figure 2. The complicated parallel facts stream must be converted into an analogue signal this is suitable to the transmission channel.

## International Journal of Innovative Research in Science, Engineering and Technology

(A High Impact Factor, Monthly, Peer Reviewed Journal)

Visit: [www.ijirset.com](http://www.ijirset.com)

Vol. 8, Issue 9, September 2019

The complicated parallel facts stream has to be transformed into an analogue sign that is suitable to the transmission channel. It is performed to the cyclic prefix add to the baseband modulation signal because the baseband signal is not overlap. After than the signal is splitter the two or more part according to the requirement.

### Square Root Recursive Least Square (QR-RLS) Algorithm

A QR-RLS based MIMO-OFDM channel estimation is proposed. Which uses gives rotation based QR factorization for estimator updating. Channel estimation is a center issue for recipient plan in remote correspondences frameworks. Since it is unimaginable to expect to quantify each remote direct in the field, it is critical to utilize preparing arrangements to appraise channel parameters, for example, constrictions and deferrals of the proliferation way. Since in most UWB recipients associate the got flag with corresponded a predefined format flag, an earlier learning of the remote channel parameters is important to foresee the state of the layout flag that matches the got flag.

### Mathematical Equation

Be that as it may, because of the wide data transfer capacity and diminished flag vitality, UWB beats experience extreme heartbeat twisting.

Consider the received signal at  $q^{\text{th}}$  receive antenna represented in matrix form as

$$Y(n) = (U(n).H(n)) + V(n) \tag{1}$$

The posteriori error is given by the difference between the received preamble symbol and its corresponding estimate at time n on  $q^{\text{th}}$  receiving antenna

$$e(q, n) = y(q, n) - \tilde{y}(q, n) \tag{2}$$

$$e(q, n) = y(q, n) - X_{pre}(n)\tilde{H}_q \tag{3}$$

Where  $\tilde{H}$  has the same dimensionality as H. The weighted Square-root error at time n is given by

$$e(q, n) = \sum_{i=0}^n \lambda^{n-i} (|e(q, i)|)^2 \tag{4}$$

Where  $\lambda$  is weigh factor, whose value lies between (0, 1) depending on channel fading conditions is present. Solution of the above equation gives the optimum value for the estimated channel coefficients H at time n. The optimum solution

$$H_q(n) = R^{-1}_X(n) \times R_{YqX}(n) \tag{5}$$

Where  $R_{YqX}(n)$  is the autocorrelation matrix of the preamble signal,  $R^{-1}_X(n)$  is the cross correlation matrix between received signal and the preamble signal at time n.

### Different Modulation Technique:-

**Binary Phase Shift Keying (BPSK)** is a two phase modulation scheme, where the 0's and 1's in a binary message are represented by two different phase states in the carrier signal:  $\theta=0^\circ$  for binary 1 and  $\theta=180^\circ$  for binary 0.

### Quadrature Amplitude Modulation (QAM)

Many data transmission systems migrate between the different orders of QAM, 16-QAM, 32-QAM and 64-QAM, dependent upon the link conditions. If there is a good margin, higher orders of QAM can be used to gain a faster data

## International Journal of Innovative Research in Science, Engineering and Technology

(A High Impact Factor, Monthly, Peer Reviewed Journal)

Visit: [www.ijirset.com](http://www.ijirset.com)

Vol. 8, Issue 9, September 2019

rate, but if the link deteriorates, lower orders are used to preserve the noise margin and ensure that a low bit error rate is preserved.

As the QAM order increases, so the distance between the different points on the constellation diagram decreases and there is a higher possibility of data errors being introduced. To utilize the high order QAM formats, the link must have a very good  $E_b/N_0$  otherwise data errors will be present. When the  $E_b/N_0$  deteriorate, then other the power level must be increased, or the QAM order reduced if the bit error rate is to be preserved.

MODULATION	BITS PER SYMBOL	SYMBOL RATE
BPSK	1	1 x bit rate
16QAM	4	1/4 bit rate
32QAM	5	1/5 bit rate
64QAM	6	1/6 bit rate

### IV. SIMULATION RESULT

MATLAB simulations are performed for various combinations of transmitted and received antenna in massive MIMO system. Simulation experiments are conducted to evaluate the SNR verse bit error rate (BER) performance of the proposed QR-RLS based channel estimation with different modulation technique i.e. QAM-16, QAM-32 and QAM-64 for  $8 \times 8$  system is shown in figure 3. For different value of SNR, the implemented QR-RLS based channel estimation for  $8 \times 8$  system shows BER reduction performance.

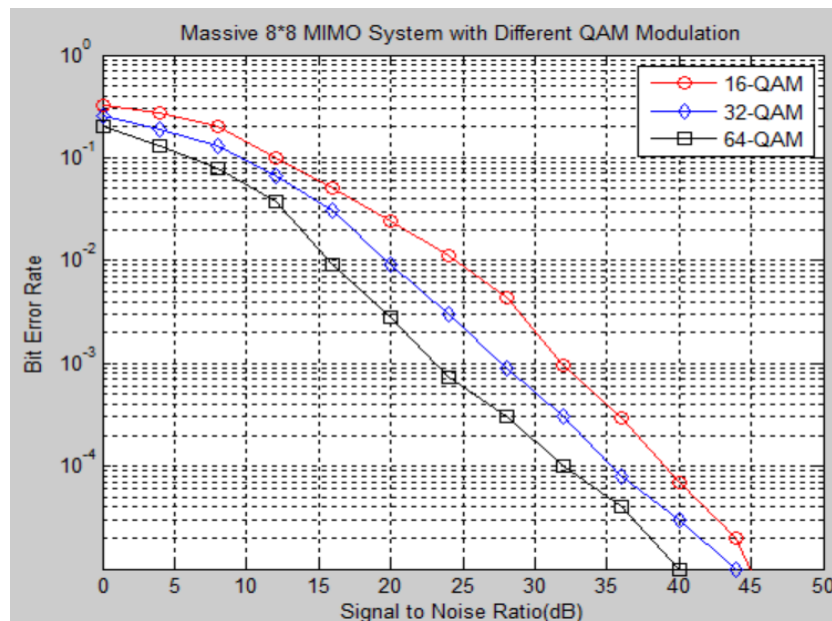

Figure 3: BER vs SNR for Massive  $8 \times 8$  System with QR-RLS based Channel Estimation Technique

Simulation experiments are conducted to evaluate the SNR VS BER performance of the proposed algorithm  $16 \times 16$  system is shown in figure 4.

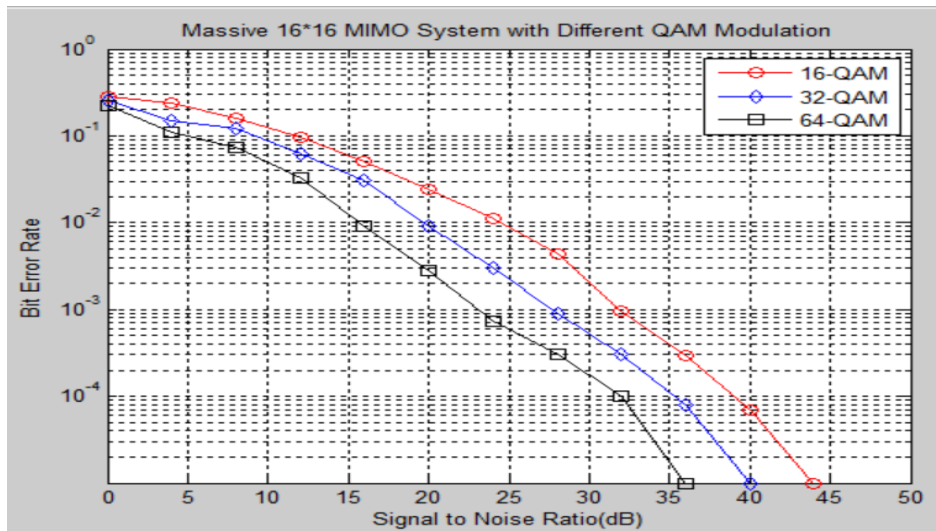

Figure 4: BER vs SNR for Massive 16×16 System with QR-RLS based Channel Estimation Technique

Simulation experiments are conducted to evaluate the SNR VS BER performance of the proposed algorithm 32×32 system is shown in figure 5.

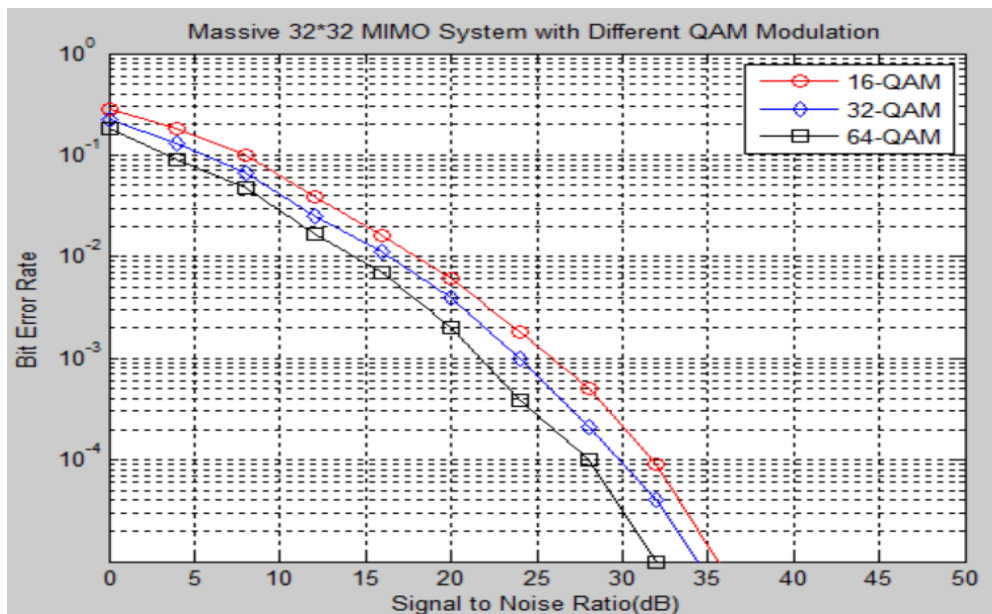

Figure 5: BER vs SNR for Massive 32×32 System with QR-RLS based Channel Estimation Technique

Simulation experiments are conducted to evaluate the SNR verse spectrum efficiency performance of the proposed QR-RLS based channel estimation with different modulation technique i.e. QAM-16, QAM-32 and QAM-64 for 8×8 system is shown in figure 6.

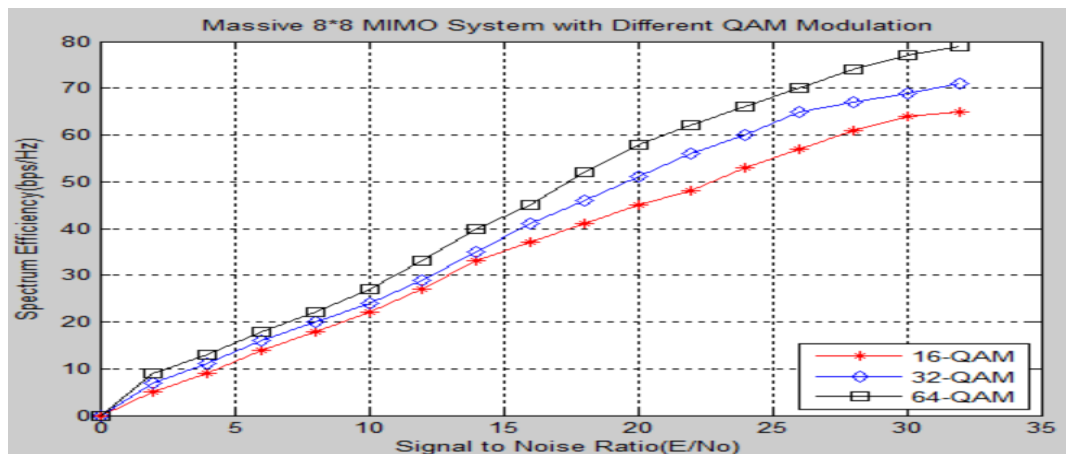

Figure 6: Spectrum Efficiency vs SNR for Massive 8x8 System with QR-RLS based Channel Estimation Technique

## V. CONCLUSION

We have developed a method for tracking the error for receiver side with knowing the transmit pre-coder or data. The proposed method is particularly useful in minimize the error in receiver side. The proposed QR-RLS based channel estimation technique with different QAM modulation technique is applied for different transmitter and receiver antenna and calculated bit error rate (BER) and spectrum efficiency with respect to signal to noise ratio (SNR). Simulation result is clear that the 32x32 transmitter and receiver antenna is best performance compared to 16x16, 8x8 transmitter and receiver antenna.

## REFERENCES

- [1] Supraja Eduru and Nakkeeran Rangaswamy, "BER Analysis of Massive MIMO Systems under Correlated Rayleigh Fading Channel", 9th ICCNT IEEE 2018, IISC, Bengaluru, India.
- [2] H. Q. Ngo A. Ashikhmin H. Yang E. G. Larsson T. L. Marzetta "Cell-free massive MIMO versus small cells" IEEE Trans. Wireless Commun. vol. 16 no. 3 pp. 1834-1850 Mar. 2017.
- [3] Huang A. Burr "Compute-and-forward in cell-free massive MIMO: Great performance with low backhaul load" Proc. IEEE Int. Conf. Commun. (ICC) pp. 601-606 May 2017.
- [4] H. Al-Hraishawi, G. Amarasuriya, and R. F. Schaefer, "Secure communication in underlay cognitive massive MIMO systems with pilot contamination," in In Proc. IEEE Global Commun. Conf. (Globecom), pp. 1-7, Dec. 2017.
- [5] V. D. Nguyen et al., "Enhancing PHY security of cooperative cognitive radio multicast communications," IEEE Trans. Cognitive Communication And Networking, vol. 3, no. 4, pp. 599-613, Dec. 2017.
- [6] R. Zhao, Y. Yuan, L. Fan, and Y. C. He, "Secrecy performance analysis of cognitive decode-and-forward relay networks in Nakagami-m fading channels," IEEE Trans. Communication, vol. 65, no. 2, pp. 549-563, Feb. 2017.
- [7] W. Zhu, J. and Xu and N. Wang, "Secure massive MIMO systems with limited RF chains," IEEE Trans. Veh. Technol., vol. 66, no. 6, pp. 5455-5460, Jun. 2017.
- [8] R. Zhang, X. Cheng, and L. Yang, "Cooperation via spectrum sharing for physical layer security in device-to-device communications under laying cellular networks," IEEE Trans. Wireless Communication, vol. 15, no. 8, pp. 5651-5663, Aug. 2016.
- [9] K. Tourki and M. O. Hasna, "A collaboration incentive exploiting the primary-secondary systems cross interference for PHY security enhancement," IEEE J. Sel. Topics Signal Process., vol. 10, no. 8, pp. 1346-1358, Dec 2016.
- [10] T. Zhang et al., "Secure transmission in cognitive MIMO relaying networks with outdated channel state information," IEEE Access, vol. 4, pp. 8212-8224, Sep. 2016.
- [11] Y. Huang et al., "Secure transmission in spectrum sharing MIMO channels with generalized antenna selection over Nakagami-m channels," IEEE Access, vol. 4, pp. 4058-4065, Jul. 2016.