

PV Panel Based Active Harmonic Filtering by Current Controlled Method in Grid Connected System

M.C Subashini, Dr. R.Raja, Dr.S.Saravanan

Department of EEE, Muthayammal Engineering College, Rasipuram, Namakkal, India

Assistant Professor, Department of EEE, Muthayammal Engineering College, Rasipuram, Namakkal, India

Assistant Professor, Department of EEE, Muthayammal Engineering College, Rasipuram, Namakkal, India

ABSTRACT: Increasing application of nonlinear loads may cause distribution system power quality issues. In order to utilize distributed generation (DG) unit interfacing converters to actively compensate harmonics, this paper proposes a current controlled method. Installing additional filters is not very favorable due to cost concern. Alternatively, distribution system power quality enhancement using flexible control of grid connected DG units becoming an interesting topic. Basically this paper rigged up for fundamental current control. As the proposed current controller have two well decoupled control branches to independently control fundamental and harmonic DG currents. If the specification for the active power and reactive power is given, fundamental current reference can be generated. The fundamental current is separated from the harmonic rich load current by tuned second order filter. These filters are sharply tuned filters. The sum of the harmonic voltage is the contribution to the distortion in the voltage at the point of contact. The distortion can be minimized by the feedback procedure. The feedback gain of the system has been described as $[1/R]$. As $[1/R]$ increases the THD decreases. If the capacitor c is reduced, the line current distortion reduces. If the capacitor c is increased harmonic current would increase and cause worsening of THD.

KEYWORDS: Distributed generation, Power quality, Harmonics, Active harmonic filtering, PWM, Resonant controller, Harmonic extraction.

I. INTRODUCTION

At increasing rates, various influences within the energy market are posing new challenges to traditional methods of delivering electrical energy. It is far more economically sound for many homeowners, business-owners, and even grid operators to produce their own energy with small generators than it has previously been. The reasons for this are numerous and debatable but include such motivations as environmental concerns, increases in cost to traditional energy sources, reductions in cost to new technologies, political incentives, and many other factors. While there have been utility customers producing their own energy for a very long time, the increasing quantity and changes in methodologies of this production pose many new challenges. From the customer's point of view, the electric power has to be received without interference or interruption. On the other hand, from the grid's point of view the power quality deals with the waveforms of current and voltage in an ac system, harmonic components in bus voltages and load currents, spikes and momentary low voltages, and other types of distortion [7]. Over the past few years, the growth in employment nonlinear loads (such as adjustable speed drives, power converters, arc furnaces and transformers) has caused many power quality problems like high harmonic content [11], sometimes resulting in overheated transformers, overheated neutrals, blown fuses and tripped circuit breakers (or breakers failing to trip in some cases). Nonlinear loads appear to be current sources injecting harmonic currents into the supply network through the utility's Point of Common Coupling (PCC). This results in distorted voltage drop across the source impedance, which causes voltage distortion at the PCC.

To compensate distribution system harmonic distortions, a number of active and passive filtering methods have been developed [3]. However, installing additional filters is not very favorable due to cost concerns. Alternatively, distribution system power quality enhancement using flexible control of grid connected DG units is becoming an interesting topic [5]–[12], where the ancillary harmonic compensation capability is integrated with the DG primary power generation function through modifying control references. This idea is especially attractive considering that the available power from backstage renewable energy resources is often lower than the power rating of DG interfacing converters.

There are two general categories of harmonic sources: saturable devices and power electronic devices. Saturable devices produce harmonics mainly due to iron saturation, as is the case for transformers, machines, and fluorescent lamps (with magnetic ballasts). The resulting magnetizing [13], [15] currents are peaked and rich in the third harmonic. Their current distortion is due to the arc and ballast. Power electronic loads draw power only during portions of the applied voltage waveform. These loads include switch-mode power supplies, fluorescent lights (with electronic ballasts), voltage source converters, pulse-width modulated converters, to mention just a few desktop computers, video monitors, and televisions have similar waveforms.

II. MODELING OF ACTIVE FILTER AND DISTRIBUTED GENERATOR

Generally, the term Distributed or Distributed Generation refers to any electric power production technology that is integrated within distribution systems, close to the point of use. Distributed generators are connected to the medium or low voltage grid. They are not centrally planned and they are typically smaller than 30 MW. The concept of DG contrasts with the traditional centralized power generation concept, where the electricity is generated in large power stations and is transmitted to the end users through transmission and distribution lines. While central power systems remain critical to the global energy supply, their flexibility to adjust to changing energy needs is limited. Central power is composed of large capital-intensive plants and a transmission and distribution (T&D) grid to disperse electricity.

A distributed electricity system is one in which small and micro generators are connected directly to factories, offices, and households and to low-voltage distribution networks. Electricity not demanded by the directly connected customers is fed into the active distribution network to meet demand elsewhere. Electricity storage systems may be utilized to store any excess generation. Large power stations and large-scale renewable, e.g. offshore wind remain connected to the high voltage transmission network providing national back up and ensure quality of supply. Again, storage may be utilized to accommodate the variable output of some forms of generation.

The non-traditional operating model of DG has drawn strong interest because of its potential to cost effectively increase system capacity while meeting the industry restructuring objective of market driven, customer-oriented solutions. These distributed generation systems, capable of operating on a broad range of gas fuels, offer clean, efficient, reliable, and flexible on-site power alternatives. This emerging portfolio of distributed generation options being offered by energy service companies and independent power producers is changing the way customers view energy. Both options require significant investments of time and money to increase capacity. Distributed generation complements central power providing in many cases a relatively low capital cost response to incremental increases in power demand, avoiding T&D capacity upgrades by locating power where it is most needed, and having the flexibility to put power back into the grid at user sites. Significant technological advances through decades of intensive research have yielded major improvements in the economic, operational, and environmental performance of small, modular gas-fuelled power generation options.

With the rapid development in semiconductor industry, power electronics devices have gained popularity in industries and also in household electrical appliances. Although these power electronics devices have benefited the electrical and electronics industry, these non-linear devices are the main source of harmonics in the power system. Harmonic is a sinusoidal component of a periodic wave and its frequency is an integral multiple of the fundamental frequency. These power harmonics are called electrical pollution which will degrade the quality of the power supply. They also cause disturbance to other consumers and interference in nearby communication networks, low system efficiency and poor power factor.

The Active Power Filter (APF) based on power electronics technology is a viable solution for power conditioning to suppress the harmonics in the power system. To compensate distribution system harmonic distortions, a number of active and passive filtering methods have been developed [3].

This idea is especially attractive considering that the available power from backstage renewable energy resources is often lower than the power rating of DG interfacing converters. For the local load harmonic current compensation methods as discussed in [5]–[12], an accurate detection of local load harmonic current is important. Various types of harmonic detection methods [4] have been presented, such as the Fourier transformation-based detection method in [13], the detection scheme using instantaneous real and reactive power theory in [14], second-order generalized integrator (SOGI) in [15], and the delayed-signal-cancellation-based detection in [32]. Nevertheless, harmonic extraction process substantially increases the computing load of DG unit controllers. For a cost-effective DG unit with limited computing ability, complex harmonic extraction methods might not be acceptable.

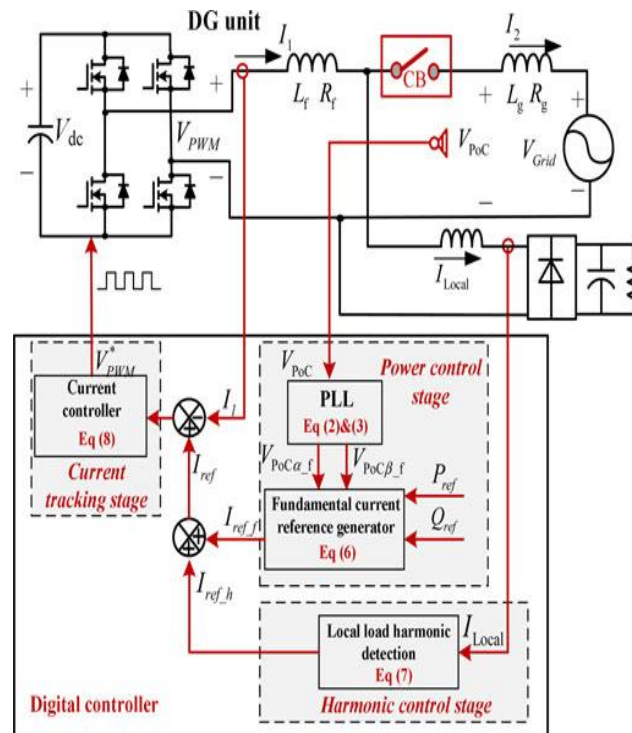

Fig. 1. DG unit with local load harmonic current compensation capability.

Alternatively, an interesting harmonic detection method was proposed in [16] and [17]. It shows that the main grid current can be directly controlled to be sinusoidal, instead of regulating DG output current to absorb local load harmonics. In this scenario, local load current is essentially treated as a disturbance in the grid current regulation loop. It should be noted that DG system normally has smaller stability margin when the direct control of grid current is employed.

Power system normally operates at 50 Hz frequency. Most of the loads installed in present-day power systems are harmonic current generators. Combined with the impedance of the electrical system, the loads also produce harmonic voltages. The nonlinear loads may therefore be viewed as both harmonic current generators and harmonic voltage generators. If the content of non-linear loads becomes too large, it produces significant distortion to the AC voltage.

Large size capacitor is connected to the inverter such that constant level of voltage could be maintained over each switching cycle. An inductor is connected in series with the inverter circuit which provides smoothing and isolation for high frequency components. Control of the injected current wave shape is limited by the switching frequency of the inverter and the available driving voltage across the interfacing inductance. This driving voltage determines the maximum di/dt that can be achieved by the filter. This is important because high values of di/dt may be needed to cancel higher order harmonic components. A large value of interfacing inductance is better for isolation but it limits the ability of an active filter to cancel higher order harmonics.

There are numerous published methods which describe different topologies and different control strategies for active power filtering. This section investigates a comprehensive review of current control strategies. A hysteresis band is usually needed to define the switch function and it also determines the switching frequency. However, the magnitude of the hysteresis band is practically very small and difficult to control, also the slope of the reference current is unpredictable which leads to increase in switching frequency, have proposed a hysteresis current controller with fixed switching frequency which results in low current tracking error; but, this method is found to result in high value of total harmonic distortion with increased amount of neutral current have proposed an adaptive hysteresis band controller for active power filter application.

III. SIMULATIONS, RESULTS AND DISCUSSION

In this section, simulation results of the current control are presented. The results prove the validity of adaptive harmonic elimination technique in the attenuation of lower order harmonics. The technique is found to be reducing the distortion due to non linear load.

The Grid is built out of a voltage controlled voltage source, driven by a cosine signal generator. The ladder filter has been replaced by an LC filter. This is an equivalent filter and is quite a good LPF. The inverter is suddenly connected to the grid by a switch at $t = 0.02$ second. The Inverter voltage and the grid voltage are approximately in phase (A PLL if used will guarantee this. However, in the above circuit, PLL was not used. Basically the circuit is rigged up for fundamental current control. This current is made to pass through the load, using the power amplifier (namely the Inverter). The fundamental current is separated from the harmonic rich load current by a tuned 2nd order filter.

First, the fundamental PoC voltage $V_{PoC\alpha-f}$ and its orthogonal component $V_{PoC\beta-f}$ (quarter cycle delayed respect to $V_{PoC\alpha-f}$) are obtained by using SOGI [15] as

$$V_{poC\alpha f} = \frac{2\omega_{D1}s}{s^2 + 2\omega_{D1}s + \omega_f^2} \cdot V_{poC} \quad (1)$$

$$V_{poC\beta f} = \frac{2\omega_{D1}\omega_f}{s^2 + 2\omega_{D1}s + \omega_f^2} \cdot V_{poC} \quad (2)$$

If the specifications for the active power P and reactive power Q are given, we can generate the fundamental current reference.

$$I_{ref-f} = I_{ref\alpha-f} = \frac{2(V_{PoC\alpha-f}P_{ref} + V_{poC\beta-f}Q_{ref})}{V_{poC\alpha-f}^2 + V_{poC\beta-f}^2} \quad (3)$$

Moreover, to absorb the harmonic current of local non linear load, the DG harmonic current reference (I_{ref-h}) is produced

$$I_{ref-h} = G_D(s) \cdot I_{Local} = \sum_{h=3,5,7,9} \frac{2\omega_{Dh}s}{s^2 + 2\omega_{Dh}s + \omega_h^2} \cdot I_{Local} \quad (4)$$

Where $G_D(s)$ is the transfer function of the harmonic extractor. To realize selective harmonic compensation performance, $G_D(s)$ is designed to have a set of band pass filters with cutoff frequency ω_{Dh} . With the derived fundamental and harmonic current references, the DG current reference can be calculated. The proportional and multiple resonant controllers [12] are adopted to ensure rapid current tracking

$$\begin{aligned} V_{PWM}^* &= G_{cur}(s) \cdot (I_{ref} - I_1) \\ &= (K_p + \sum_{h=f,3,5,\dots,15} \frac{2K_{ih}\omega_{ch}s}{s^2 + 2\omega_{ch}s + \omega_h^2}) \cdot (I_{ref-f} + I_{ref-h} - I_1) \end{aligned} \quad (5)$$

where V_p is the reference voltage for pulse width modulation(PWM) processing, K_p the proportional gain of the current Controller $G_{cur}(s)$, K_{ih} the resonant controller gain at the order h , ω_{ch} the cutoff frequency of the resonant controller, and ω_{ch} is the angular frequency at fundamental and selected harmonic frequencies.

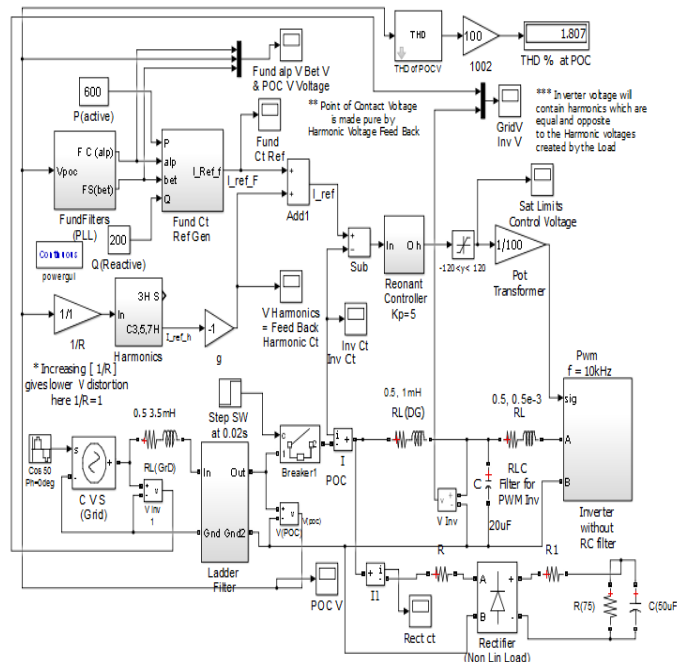

Fig. 2. Simulation block, Single Phase Inverter as DG

The filters are sharply tuned by using smaller values for delta. In this simulation, delta for all the filters is about 0.01. If delta is 0.1, then the filter gets broadly tuned. It may not isolate the harmonics as well as the fundamental voltage satisfactorily. There will be leakage of one signal into another. The sharper the filter, the greater will be gain. However, sharper the filter, slower it will be, particularly while responding to sudden changes. Also, sharply tuned filters will extract the signals with fidelity, in the steady state. Further, the gain for sharply tuned filters will be greater than that of the broadly tuned filters

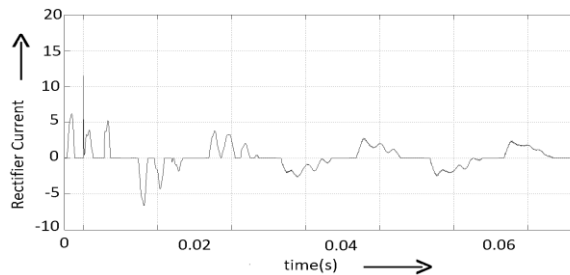

Fig. 3. Rectifier Current-Load side

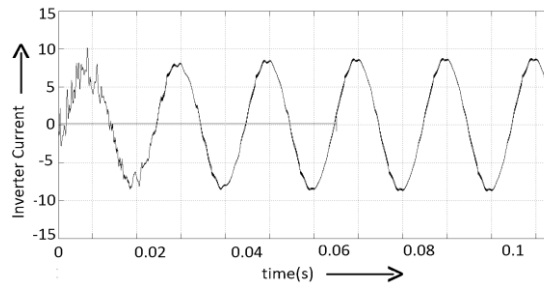

Fig. 4. Inverter Current

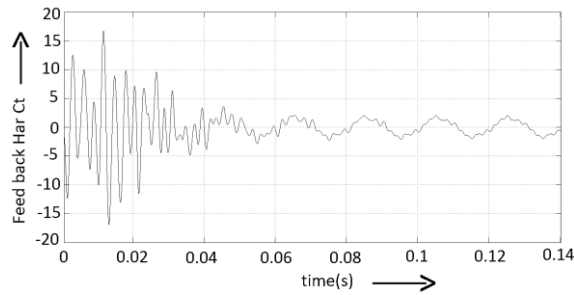

Fig. 5. Feed back Harmonic Current

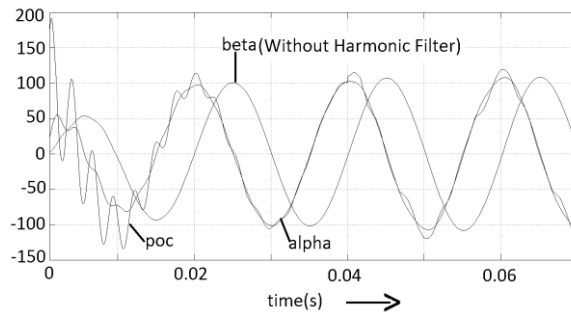

Fig. 6. Fundamental V-alpha, V-beta, V-poc (Without using filters)

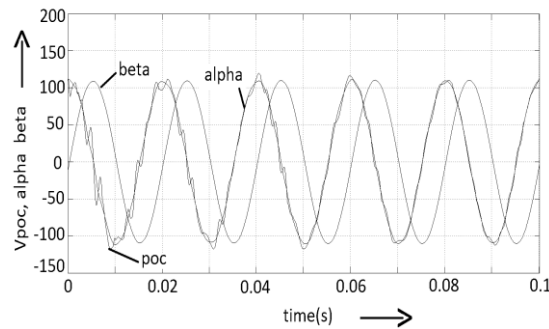

Fig. 7. Fundamental V-alpha, V-beta, V-poc (With filters)

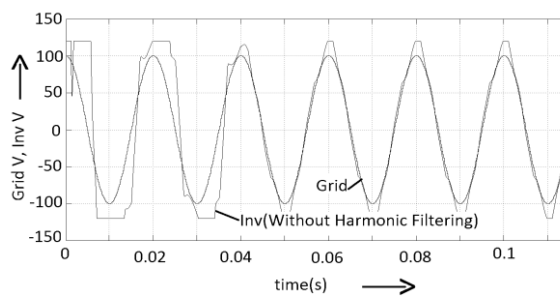

Fig. 8. Grid-V, Inv-V (Without using Filters)

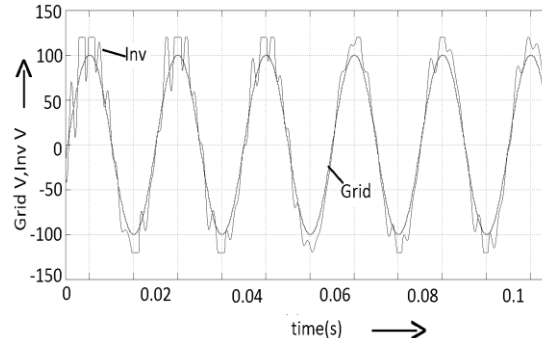

Fig. 9. Grid-V, Inv-V (with filters)

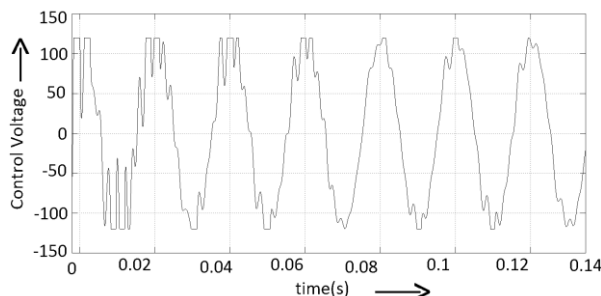

Fig.10. Saturation limit control voltage (CVS as DG)

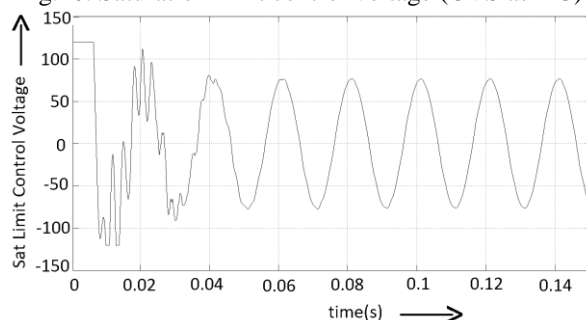

Fig. 11. Saturation Limit Control Voltage (Inverter as DG)

IV. CONCLUSION

In this paper, a simple harmonic compensation strategy is proposed for current-controlled DG unit interfacing converters. The proposed method realizes power control and harmonic compensation without using any local nonlinear load harmonic current extraction or PoC harmonic voltage detection. Another advantage of this method is no need of additional filters. The distributed generator inverters itself eliminate harmonic effectively. Moreover, the input of the fundamental power control branch is regulated by a closed-loop power control scheme, which avoids the adoption of PLLs. The proposed power control method ensures accurate power control even when harmonic compensation tasks are activated in the DG unit or the PoC voltage changes. Simulated and experimental results from a single-phase DG unit verified the feasibility of the proposed strategy.

REFERENCES

- [1] F. Blaabjerg, Z. Chen, and S. B. Kjaer, "Power electronics as efficient interface in dispersed power generation systems," *IEEE Trans. Power Electron.*, vol. 19, no. 5, pp. 1184–1194, Sep. 2004.
- [2] F. Wang, J. L. Duarte, M. A. M. Hendrix, and P. F. Ribeiro, "Modeling and analysis of grid harmonic distortion impact of aggregated DG inverters," *IEEE Trans. Power Electron.*, vol. 26, no. 3, pp. 786–797, Mar. 2011.
- [3] L. Asiminoaei, F. Blaabjerg, S. Hansen, and P. Thogersen, "Adaptive compensation of reactive power with shunt active power filters," *IEEE Trans. Ind. Appl.*, vol. 44, no. 3, pp. 867–877, May/Jun. 2008.
- [4] L. Asiminoaei, F. Blaabjerg, and S. Hansen, "Detection is key—Harmonic detection methods for active power filter applications," *IEEE Ind. Appl. Mag.*, vol. 13, no. 4, pp. 22–33, Jul./Aug. 2007.
- [5] N. Pogaku and T. C. Green, "Harmonic mitigation throughout a distribution system: A distributed-generator-based solution," in *IEE Proc. Gener. Transm. Distrib.*, vol. 153, no. 3, pp. 350–358, May 2006..
- [6] C. J. Gajanayake, D. M. Vilathgamuwa, P. C. Loh, R. Teodorescu, and F. Blaabjerg, "Z-source-inverter-based flexible distributed generation system solution for grid power quality improvement," *IEEE Trans. Energy Convers.*, vol. 24, no. 3, pp. 695–704, Sep. 2009.
- [7] R. I. Bojoi, G. Griva, V. Bostan, M. Guerriero, F. Farina, and F. Profumo, "Current control strategy of power conditioners using sinusoidal signal integrators in synchronous reference frame," *IEEE Trans. Power. Electron.*, vol. 20, no. 6, pp. 1402–1412, Nov. 2005.
- [8] T.-L. Lee and P.-T. Cheng, "Design of a newcooperative harmonic filtering strategy for distributed generation interface converters in an islanding network," *IEEE Trans. Power Electron.*, vol. 22, no. 5, pp. 1919–1927, Sep. 2007.
- [9] B. Han, B. Bae, H. Kim, and S. Baek, "Combined operation of unified power-quality conditioner with distributed generation," *IEEE Trans. Power Del.*, vol. 21, no. 1, pp. 330–338, Mar. 2003.

- [10] M. Cirrincione, M. Pucci, and G. Vitale, "A single-phase DG generation unit with shunt active power filter capability by adaptive neural filtering," *IEEE Trans. Ind. Electron.*, vol. 55, no. 5, pp. 2093–2010, May 2008.
- [11] R. I. Bojoi, L. R. Limongi, D. Ruiu, and A. Tenconi, "Enhanced power quality control strategy for single-phase inverters in distributed generation systems," *IEEE Trans. Power Electron.*, vol. 26, no. 3, pp. 798–806, Mar. 2011.
- [12] J. He, Y. W. Li, and S. Munir, "A flexible harmonic control approach through voltage controlled DG-Grid interfacing converters," *IEEE Trans. Ind. Electron.*, vol. 59, no. 1, pp. 444–455, Jan. 2012.
- [13] B. P. Mcgrath, D. G. Holmes, and J. J. H. Galloway, "Power converter line synchronization using a discrete Fourier transform (DFT) based on a variable sample rate," *IEEE Trans. Power Electron.*, vol. 20, no. 4, pp. 877–884, Apr. 2005.
- [14] H. Akagi, Y. Kanazawa, and A. Nabae, "Instantaneous reactive power compensation comprising switching devices without energy storage components," *IEEE Trans. Ind. Appl.*, vol. 20, no. 3, pp. 625–630, Mar/Apr. 1984.
- [15] F. Blaabjerg, R. Teodorescu, M. Liserre, and A. V. Timbus, "Overview of control and grid synchronization for distributed power generation systems," *IEEE Trans. Ind. Electron.* vol. 53, no. 5, pp. 1398-1409, Oct. 2006.
- [16] A. Timbus, M. Liserre, R. Teodorescu, P. Rodriguez and F. Blaabjerg, "Evaluation of Current Controllers for Distributed Power Generation Systems," *Power Electronics, IEEE Transactions on*, vol.24, no.3, pp.654,664, March. 2009
- [17] A. V. Timbus, M. Liserre, R. Teodorescu and F. Blaabjerg, "Synchronization methods for three phase distributed power generation systems. An overview and evaluation," *Proc. IEEE PESC*, pp. 2474-2481, 2005.
- [18] L. H. Tey, P. L. So and Y. C. Chu, "Improvement of power quality using adaptive shunt active filter," *Power Delivery, IEEE Transactions on*, vol.20, no.2, pp.1558,1568, April. 2005.
- [19] L. N. Arruda, S. M. Silva and B. Filho, "PLL structures for utility connected systems," *Proc. IEEE-IAS Annu. Meeting*, vol. 4, pp. 2655–2660. 2001.
- [20] A. Chaoui, JP. Gaubert, F. Krim and G. Champenos, "PI Controlled Three- phase Shunt Active Power Filter for Power Quality Improvement," *Electric Power components and systems*, vol. 35, issue. 12. 2007.