

Automatic Rain Operated Wiper and Headlight Dim and Bright Controller

Vijay S¹, Siva Sankar A², Mohammed Riyaz Khan M³, Ganesh Kumar S⁴

U.G. Student, Department of Automobile Engineering, JKKM College of Tech, Tamilnadu, India¹

U.G. Student, Department of Automobile Engineering, JKKM College of Tech, Tamilnadu, India²

U.G. Student, Department of Automobile Engineering, JKKM College of Tech, Tamilnadu, India³

Assistant Professor, Department of Mechanical Engineering, JKKM College of Tech, Tamilnadu, India⁴

ABSTRACT: In our concept of the project is to prevent the accidents in the automobile vehicles during rainy seasonal time. During the raining, driver is not visible clearly to opposite vehicles in the road. For avoiding this problem, we introducing our new project, which is fully equipped by sensors circuit, dim/bright light and wiper motor. The control unit receives the signal, wiper operates and head light dim/bright relay switches automatically. Keeping the rain sensor in the fibre glass. During the rainy time rain sensor sense and it send to control unit. The control unit operates both the wiper motor and dim and bright light. The main merit of the project is to avoid accident. Easy transportation of vehicles and delivery of goods at correct time. It is applying for all transportation vehicles and passenger vehicles. we are using the material as mild steel for frame, lead acid battery fibre glass.

KEYWORDS: Automobiles, Fibre glass, Wiper, Passenger Vehicles

I. INTRODUCTION

Car safety is the avoidance of automobile accidents or the minimization of harmful effects of accidents, in particular as pertaining to human life and health. It is a genuine project which is fully equipped and designed for Automobile vehicles. This forms an integral part of best quality. This product underwent strenuous test in our Automobile vehicles and it is good. Man has needed and used energy at an increasing rate for its sustenance and wellbeing ever since he came on the earth a few million years ago.

Primitive man required energy primarily in the form of food. He derived this by eating plants or animals, which he hunted. Subsequently he discovered fire and his energy needs increased as he started to make use of wood and other bio mass to supply the energy needs for cooking as well as agriculture.

With further demand for energy, man began to use the wind for sailing ships and for driving windmills, and the force of falling water to turn water wheels. Till this time, it would not be wrong to say that the sun was supplying all the energy needs of man either directly or indirectly and that man was using only renewable sources of energy.

1.1 Description of Parts

Rain operated wiper contains the following parts,

1. Conductive Sensor
2. Class frame and Supporting Structure
3. Wiper Motor and its arrangement

International Journal of Innovative Research in Science, Engineering and Technology

(A High Impact Factor, Monthly, Peer Reviewed Journal)

Visit: www.ijirset.com

Vol. 9, Issue 2, February 2020

1.2 Rear wipers

Some vehicles are fitted with wipers (with or without washers) on the back window as well. Rear-window wipers are typically found on hatchbacks, station wagons / estates, sport utility vehicles, minivans, and other vehicles with more vertically-oriented rear windows that tend to accumulate dust.

1.3 Headlight wipers

In the 1960s, as interest in auto safety grew, engineers began researching various headlamp cleaning systems. In late 1968, Chevrolet introduced high pressure fluid headlamp washers on a variety of their 1969 models. In 1970, Saab Automobile introduced headlight wipers across their product range. These operated on a horizontal reciprocating mechanism, with a single motor. They were later superseded by a radial spindle action wiper mechanism, with individual motors on each headlamp. In 1972, headlamp cleaning systems became mandatory in Sweden.

Headlamp wipers have all but disappeared today with most modern designs relying solely on pressurized fluid spray to clean the headlights. This reduces manufacturing cost, minimizes aerodynamic drag, and complies with EU regulations limiting headlamp wiper use to glass-lensed units only (the majority of lenses today are made of plastic.)

II.LITERATURE SURVEY

Prajakta Chapakanade [1] et al., explains the automatic rain operated wipers and dimmer for vehicles. In modern days, the accidents are most common in vehicles. One of the reasons for these accidents is glare of light faced by the driver, coming from the opposite side of the vehicle. In rainy seasons for many vehicles, the wiper on the windshield has to be controlled manually by the driver. This causes distraction while driving. The main aim of the project is to prevent the distractions to the driver of a vehicle. The principle of conductivity is used for the working of wiper sensor. The programmed microcontroller is used to actuate the wiper motor. The principle of LDR is used so that when a high intense light falls on vehicle, the lower dimmer will be turned on and when low intense beam of light is detected then the upper dimmer is switched on.

K. V. Viswanadh [2] et al., an era of automation where it is broadly defined as replacement of manual effort by mechanical power in all degrees of automation. Now a day's almost all the automobile vehicles are being atomized in order to reduce human efforts. The AUTOMATIC RAIN OPERATED WIPER system is a fully automation project. This is a genuine project which is designed for automobile vehicles and is fully equipped by sensor circuit and wiper motor. This project work includes design and development of a control system based on electronically controlled automotive rain operated motor called AUTOMATIC RAIN OPERATED WIPER.

III.BLOCK DIAGRAM

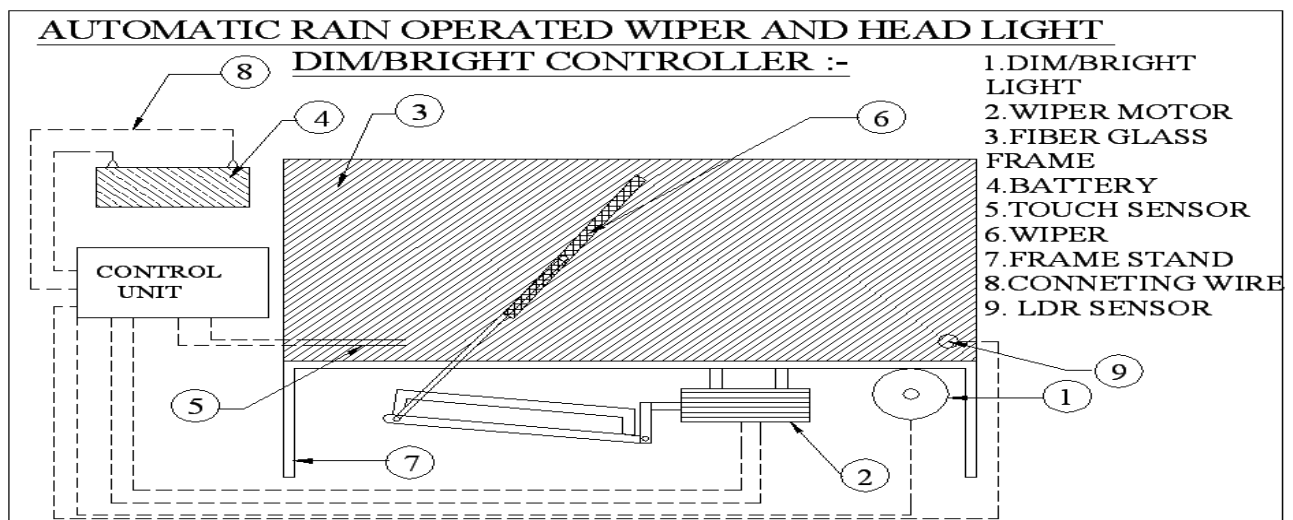

Fig 3.1 AUTOMATIC RAIN OPERATED WIPER AND HEADLIGHT DIM AND BRIGHT CONTROLLER

International Journal of Innovative Research in Science, Engineering and Technology

(A High Impact Factor, Monthly, Peer Reviewed Journal)

Visit: www.ijirset.com

Vol. 9, Issue 2, February 2020

IV.LIST OF COMPONENTS USED TO PROJECT

1. DIM/BRIGHT LIGHT
2. WIPER MOTOR
3. FIBER GLASS FRAME
4. BATTERY
5. WIPER
6. TOUCH SENSOR
7. FRAME STAND
8. CONNECTING WIRE
9. LDR SENSOR

4.1 WIPER MOTOR



Fig 4.1 Wiper Motor

A windscreen wiper or windshield wiper is a device used to remove rain, snow, ice and debris from a windscreen or windshield. Almost all motor vehicles, including cars, trucks, train locomotives, watercraft with a cabin and some aircraft, are equipped with such wipers, which are usually a legal requirement.

A wiper generally consists of a metal arm, pivoting at one end and with a long rubber blade attached to the other. The arm is powered by a motor, often an electric motor, although pneumatic power is also used in some vehicles. The blade is swung back and forth over the glass, pushing water or other precipitation from its surface. The speed is normally adjustable, with several continuous speeds and often one or more "intermittent" settings. Most automobiles use two synchronized radial type arms, while many commercial vehicles use one or more pantograph arms.

On some vehicles, a windshield washer system is also used. This system sprays water or an antifreeze window washer fluid at the windshield using several nozzles. The windshield washer system helps to remove dirt or dust from the windshield when it is used in concert with the wiper blades. When antifreeze windshield washer fluid is used, it can help the wipers to remove snow or ice. For winter conditions, some vehicles have additional heaters aimed at the

International Journal of Innovative Research in Science, Engineering and Technology

(A High Impact Factor, Monthly, Peer Reviewed Journal)

Visit: www.ijirset.com

Vol. 9, Issue 2, February 2020

windows or embedded heating wire in the glass. These defroster systems help to keep snow and ice from building up on the windshield. In rare cases, miniature wipers are installed on headlights.

Wipers may be powered by a variety of means, although most in use today are powered by an electric motor through a series of mechanical components, typically two 4-bar linkages in series or parallel.

Vehicles with air operated brakes sometimes use pneumatic wipers, powered by tapping a small amount of pressurized air from the brake system to a small air operated motor mounted on or just above the windscreen. These wipers are activated by opening a valve which allows pressurized air to enter the motor.

Early wipers were often driven by a vacuum motor powered by manifold vacuum. This had the drawback that manifold vacuum varies depending on throttle position, and is almost non-existent under wide-open throttle, when the wipers would slow down or even stop. This problem was overcome somewhat by using a combined fuel/vacuum booster pump.

Some cars, mostly from the 1960s and 1970s, had hydraulically driven wipers, most notably the '61-'69 Lincoln Continental.

On the earlier Citroën 2CV, the windscreen wipers were powered by a purely mechanical system, a cable connected to the transmission; to reduce cost, this cable also powered the speedometer. The wipers' speed was therefore variable with car speed. When the car was waiting at an intersection, the wipers were not powered, but a handle under the speedometer allowed the driver to power them by hand.

4.2 SENSOR

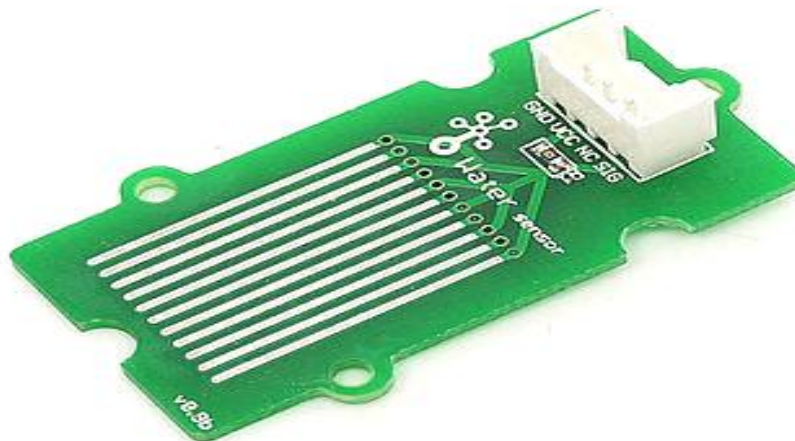

Fig 4.2 Sensor

In the broadest definition, a sensor is an object whose purpose is to detect events or changes in its environment, and then provide a corresponding output. A sensor is a type of transducer; sensors may provide various types of output,

International Journal of Innovative Research in Science, Engineering and Technology

(A High Impact Factor, Monthly, Peer Reviewed Journal)

Visit: www.ijirset.com

Vol. 9, Issue 2, February 2020

but typically use electrical or optical signals. For example, a thermocouple generates a known voltage (the output) in response to its temperature (the environment). A mercury-in-glass thermometer, similarly, converts measured temperature into expansion and contraction of a liquid, which can be read on a calibrated glass tube.

Sensors are used in everyday objects such as touch-sensitive elevator buttons (tactile sensor) and lamps which dim or brighten by touching the base, besides innumerable applications of which most people are never aware. A sensor's sensitivity indicates how much the sensor's output changes when the input quantity being measured changes.

For instance, if the mercury in a thermometer moves 1 cm when the temperature changes by 1 °C, the sensitivity is 1 cm/°C (it is basically the slope Dy/Dx assuming a linear characteristic). Some sensors can also have an impact on what they measure; for instance, a room temperature thermometer inserted into a hot cup of liquid cools the liquid while the liquid heats the thermometer. Sensors need to be designed to have a small effect on what is measured; making the sensor smaller often improves this and may introduce other advantages.[citation needed] Technological progress allows more and more sensors to be manufactured on a microscopic scale as micro sensors using MEMS technology. In most cases, a micro sensor reaches a significantly higher speed and sensitivity compared with macroscopic approaches.

4.3 TRANSFORMER

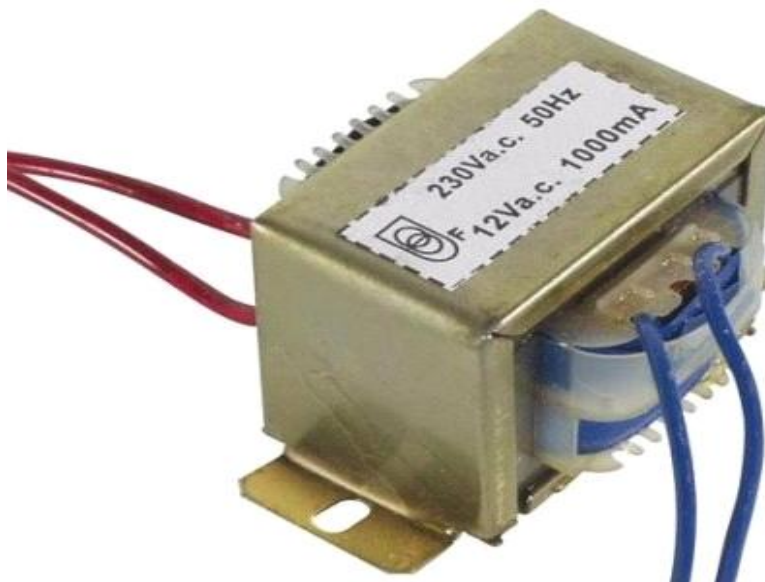

Fig 4.3 Transformer

A transformer is an electrical device that transfers electrical energy between two or more circuits through electromagnetic induction. Electromagnetic induction produces an electromotive force across a conductor which is exposed to time varying magnetic fields. Commonly, transformers are used to increase or decrease the voltages of alternating current in electric power applications.

International Journal of Innovative Research in Science, Engineering and Technology

(A High Impact Factor, Monthly, Peer Reviewed Journal)

Visit: www.ijirset.com

Vol. 9, Issue 2, February 2020

A varying current in the transformer's primary winding creates a varying magnetic flux in the transformer core and a varying magnetic field impinging on the transformer's secondary winding. This varying magnetic field at the secondary winding induces a varying electromotive force (EMF) or voltage in the secondary winding due to electromagnetic induction. Making use of Faraday's Law (discovered in 1831) in conjunction with high magnetic permeability core properties, transformers can thus be designed to efficiently change AC voltages from one voltage level to another within power networks.

Since the invention of the first constant potential transformer in 1885, transformers have become essential for the transmission, distribution, and utilization of alternating current electrical energy. A wide range of transformer designs are encountered in electronic and electric power applications. Transformers range in size from RF transformers less than a cubic centimetre in volume to units interconnecting the power grid weighing hundreds of tons.

For simplification or approximation purposes, it is very common to analyse the transformer as an ideal transformer model as presented in the two images. An ideal transformer is a theoretical, linear transformer that is lossless and perfectly coupled; that is, there are no energy losses and flux is completely confined within the magnetic core. Perfect coupling implies infinitely high core magnetic permeability and winding inductances and zero net magneto motive force.

4.4 RECTIFIER

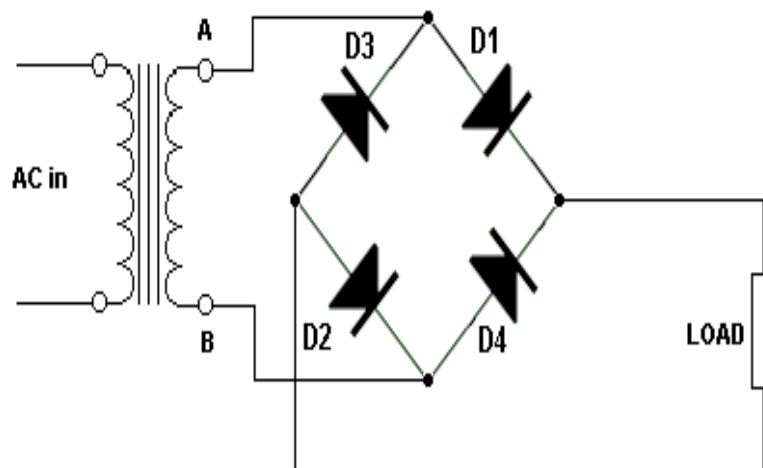

Fig 4.4 Rectifier

A rectifier is an electrical device that converts alternating current (AC), which periodically reverses direction, to direct current (DC), which flows in only one direction. The process is known as rectification. Physically, rectifiers take a number of forms, including vacuum tube diodes, mercury-arc valves, copper and selenium oxide rectifiers, semiconductor diodes, silicon-controlled rectifiers and other silicon-based semiconductor switches. Historically, even synchronous electromechanical switches and motors have been used. Early radio receivers, called crystal radios, used a "cat's whisker" of fine wire pressing on a crystal of galena (lead sulfide) to serve as a point-contact rectifier or "crystal detector"

International Journal of Innovative Research in Science, Engineering and Technology

(A High Impact Factor, Monthly, Peer Reviewed Journal)

Visit: www.ijirset.com

Vol. 9, Issue 2, February 2020

V. WORKING PRINCIPLE

We introduced automatic rain operated wiper assembly and head light dim and bright light. we are using the component is dim and bright breaker circuit, wiper motor, control unit, battery. We are fixing the rain sensor in the fibre glass. The power supply is given by the battery to control unit. The control unit receives the signal from touch sensor and LDR sensor. The control unit receives the signal, wiper motor operates and head light dim/bright relay switches automatically. Keeping the rain sensor in the fibre glass. During the rainy time, rain sensor sense the rain water, and it send the signal to control unit. The control unit operates both the wiper motor and dim and bright light.

VI. FACTORS DETERMINING THE CHOICE OF MATERIALS

The various factors which determine the choice of material are discussed below.

1. PROPERTIES

The concept of Automatic Wipers with Mist Control has been implemented successfully. After the experimental setup the wiper motor was tested for all the following conditions drizzling, heavy rain, and medium rain. The tests have been conducted under mist on the wind shield. The mist has been removed successfully from the wind shield. By the uses of automatic wipers one can drive the commercial vehicles without any distractions to operate the wiper. Use of internal wipers ensures good visibility to the driver, which in turn prevents the accident.

The following four types of principle properties of materials decisively affect their selection:

1. Mechanical
2. From manufacturing point of view

Here we have used BC547 Transistor .It is an npn transistor. The transistor is triggered when the bridge of LDR is unbalanced and thus transistor works in conduction mode. The transistor is used for switching purpose as well as amplifier. The various properties concerned from the manufacturing point of view are,

1. Cast ability
2. Weld ability

2. WINDSHIELD AND CONDUCTIVE SENSOR

Windshield is used for protection of driver from rain, dust. On the windshield the conductive sensor is placed. As the rain falls on the windshield it is detected by the sensor as enhanced Flash program memory, reduced power consumption and extended instruction set. The output from the conductive sensor is given to PIC. The PIC requires 5V signal. The signal from PIC is further given to motor. To drive the motor, driver is used because motor requires voltage greater than the 5V, which is given by PIC as input to motor.

VII. CONCLUSION

As almost everything described already for this design , we would like to say there are still numerous kinds of enhancements one can implement on this project to make it even more convenient .The project we have made and presented is quite efficient and it is cost effective also .It has great advantage of over the optical sensor covering all the design specification together with the requirement of common man the speed controlling mechanism can be added in this project which will make it work according to the intensity and speed water coming on the sensor . The basic manoeuvring is done only to make it cost effective and reliable.

International Journal of Innovative Research in Science, Engineering and Technology

(A High Impact Factor, Monthly, Peer Reviewed Journal)

Visit: www.ijirset.com

Vol. 9, Issue 2, February 2020

VIII. MERITS AND DEMERITS

MERITS

1. Low cost automation project.
2. Less power consumption
3. Operating principle is very easy.
4. Installation is simplified very much.
5. Less time and more profit.
6. Reduces human effort by modifying the wind shield.
7. Makes the windshield free from wear adjustment.
8. Avoids the glare of light faced by the driver during night driving.
9. Reduces the accidents caused by 'toiler effect'.

DEMERITS

1. Dust particles and non-conductive particles accumulated on the surface of sensors cannot be detected by conductive sensors.

IX. APPLICATIONS

1. Four wheelers
2. Two Wheelers

REFERENCES

- [1] Prajakta Chapakanade, Pooja Gangurde, Siddhesh Peje, D.R.Shende, "Automatic Rain Operated Wiper And Dimmer For Vehicle", International Research Journal of Engineering and Technology, Volume: 03, Issue: 04, Apr-2016.
- [2] K. V. Viswanadh Ch. Siva Sankara Babu J. Leela Krishna A. Lala Bahadur, "Design & Fabrication of Rain Operated Wiper Mechanism using Conductive Sensor Circuit", International Journal of Engineering Research & Technology, Vol. 4 Issue 01, January-2015.
- [3] WWW.WIKIPEDIA.ORG