

Precast Beam Column Connection Subjected to Cyclic Loading

Kshitija Waghchoure¹, Dr. Ashok Kasnale²

M.E. Student, Dept. of Civil Engineering, Dr. D. Y. Patil School of Engineering & Technology, Pune, India¹

Principal, Dr. D. Y. Patil School of Engineering & Technology, Pune, India²

ABSTRACT: Ancient Roman builders made use of concrete and soon poured the material into moulds to build their complex network of aqueducts, culverts, and tunnels. Modern uses for pre-cast technology include a variety of architectural and structural applications — including individual parts, or even entire building systems.

In the modern world, precast paneled buildings were pioneered in Liverpool, England, in 1905. The process was invented by city engineer John Alexander Brodie, a creative genius who also invented the idea of the football goal net. The tram stables at Walton in Liverpool followed in 1906. The idea was not taken up extensively in Britain. However, it was adopted all over the world, particularly in Eastern Europe and Scandinavia.

KEYWORD: Precast, Beam, Column

I. INTRODUCTION

Precast concrete systems have many advantages like speed in construction, good quality due to factory production, economy in mass production. Despite many advantages of precast concrete, it is not widely used throughout the World, especially in regions of high seismic risk. The reason behind this is a lack of confidence and knowledge base about their performance in seismic regions as well as the absence of rational seismic design provisions in major model building codes (Priestley, 1991). High storey precast frame panel buildings performed poorly in the 1988 Spitak, Armenia earthquake due to the lack of adequate seismic design considerations such as ductility in precast joints (Hadjian, 1993). A significant number of parking structures suffered extensive damage and a number of precast concrete parking structures collapsed in the 1994, Northridge earthquake. One of the reasons for the collapse was lack of proper diaphragm connections (Mitchell et al., 1995). In the 1995 Kobe earthquake, most of the precast prestressed concrete structures performed well, only three sustained severe structural damage. The structural damage was due to insufficient connection detailing (Muguruma et al., 1995). The lessons learnt from the past earthquakes are that the connections are the weakest link. Hence more research is required in the study of connections.

A. Precast concrete products

Agricultural Products—Precast concrete products can withstand the most extreme weather conditions and will hold up for many decades of constant usage. Products include bunker silos, cattle feed bunks, cattle grid, agricultural fencing, H-bunks, J-bunks, livestock slats, livestock watering trough, feed troughs, concrete panels, slurry channels, and more. Prestress concrete panels are widely used in the UK for a variety of applications including agricultural buildings, grain stores, silage clamps, and slurry stores, livestock walling and general retaining walls. Panels can be used horizontally and placed either inside the webbing of RSJs (I-beam) or in front of them. Alternatively panels can be cast into a concrete foundation and used as a cantilever retaining wall.

B. Objective:

- 1) To study precast element and compare its aspect with RCC.
- 2) To study and collect data of specified ground motion for time history analysis.
- 3) To check and compare parameters like bending stress, shear stress and principal stress for linear and non-linear analysis.



II. LITERATURE REVIEW

Hsuan-Teh Hu *, Fu-Ming Lin, Yih-Yuan Jan, ‘nonlinear finite element analysis of reinforced concrete beams strengthened by fiber-reinforced plastics’:2004[1] Numerical analyses are performed using the ABAQUS finite element program to predict the ultimate loading capacity of rectangular reinforced concrete beams strengthened by fiber-reinforced plastics applied at the bottom or on both sides of these beams. Nonlinear material behavior, as it relates to steel reinforcing bars, plain concrete and fiber-reinforced plastics is simulated using appropriate constitutive models. The influences of fiber orientation, beam length and reinforcement ratios on the ultimate strength of the beams are investigated

Sudhakar A. Kulkarni, Bing Li, Woon Kwong Yip, ‘Finite element analysis of precast hybrid-steel concrete connections under’ 7 May 2007[2] in this paper, a nonlinear finite element (FE) analysis of hybrid-steel concrete connections is presented. The detailed experimental results of the four full-scale hybrid-steel concrete connections with limited seismic detailing have been discussed in a different paper. However, due to the inherent complexity of beam-column joints and the unique features of the tested specimens, the experimental study was not comprehensive enough. Therefore, in this paper, an analytical investigation based on the FE models and using the DIANA software is presented.

R.A. Hawileh, A. Rahman, H. Tabatabai, ‘Nonlinear finite element analysis and modeling of a precast hybrid beam-column connection subjected to cyclic loads’ 3 December 2009[3] In this work, a detailed three-dimensional (3D) nonlinear finite element model is developed to study the response and predicts the behavior of precast hybrid beam-column connection subjected to cyclic loads that was tested at the National Institute of Standards and Technology (NIST) laboratory. The precast joint is modeled using 3D solid elements and surface-to-surface contact elements between the beam/column faces and interface grouting the vicinity of the connection. The model takes into account the pre-tension effect in the post-tensioning strand and the nonlinear material behavior of concrete. The model response is compared with experimental test results and yielded good agreement at all stages of loading.

Ehsan Noroozinejad Farsangi, ‘Connections Behavior in Precast Concrete Structures Due to Seismic Loading’ 03/05/2010[4] This paper presents a finite element analysis on 4 types of precast connections which are pinned, rigid, semi rigid and a new proposed connection. The stiffness of the new connection is obtained from the slope of the total load versus deflection graph in the elastic range. Then the seismic loading from El Centro earthquake modified with 0.15g and 0.5g were applied to the whole structure. From the analysis results, new connection has sufficient stiffness, strength and also higher ductility. Meanwhile, the whole structure analysis results showed that the new connection behaves as semi rigid connection. LUSAS and SAP2000 have been used for analysis

III. METHODOLOGY

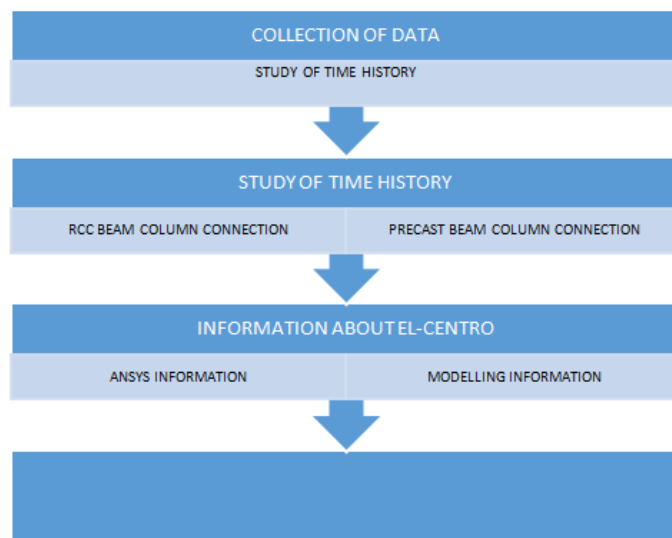



A. Material properties.

Sr.No.	Material	Property	Value
1	Structural steel	Yield stress f_{sy} (MPa)	265
		Ultimate strength f_{su} (MPa)	410
		Young's modulus E_s (MPa)	205×10^3
		Poisson's ratio μ	0.3
		Ultimate tensile strain ϵ_t	0.25
2	Reinforcing bar	Yield stress f_{sy} (MPa)	250
		Ultimate strength f_{su} (MPa)	350
		Young's modulus E_s (MPa)	200×10^3
		Poisson's ratio μ	0.3
		Ultimate tensile strain ϵ_t	0.25
3	Concrete	Compressive strength f_{sc} (MPa)	42.5
		Tensile strength f_{st} (MPa)	3.553
		Young's modulus E_c (MPa)	32920
		Poisson's ratio μ	0.15
		Ultimate compressive strain ϵ_s	0.045

IV. PROBLEM STATEMENT

A. Problem Statement

A G+9 RCC Commercial building is considered.

Plan dimensions: 12 m x 12 m

Location considered: Zone-IV

Soil Type considered: Hard Strata.

General Data of Building:

- Grade of concrete: M 25
- Grade of steel considered: Fe 250, Fe 500
- Live load on roof: 2 KN/m² (Nil for earthquake)
- Live load on floors: 4 KN/m²
- Roof finish: 1.0 KN/m²
- Floor finish: 1.0 KN/m²
- Brick wall in longitudinal direction: 240 mm thick
- Brick wall in transverse direction: 140 mm thick
- Beam in longitudinal direction: 230X350 mm
- Beam in transverse direction: 230X350 mm
- Column size: 300X750 mm
- Density of concrete: 25 KN/m³
- Density of brick wall including plaster: 20 KN/m³
- Plinth beam (PB1): 350X270 mm
- Plinth beam (PB2): 270X300 mm

V. RESULT AND ANALYSIS

A. Following are the analysis of RCC beam column connection subjected to cyclic loading in ansys.

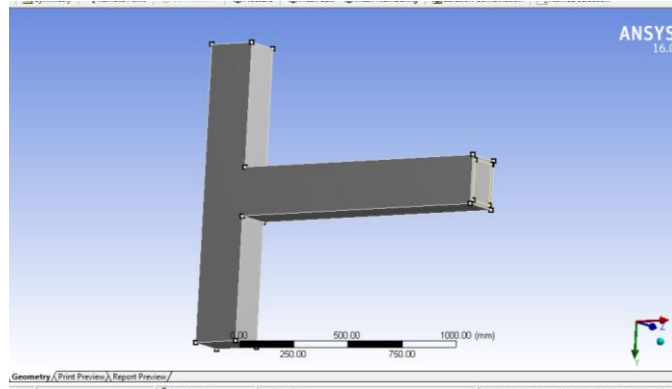

Fig 1.loading condition

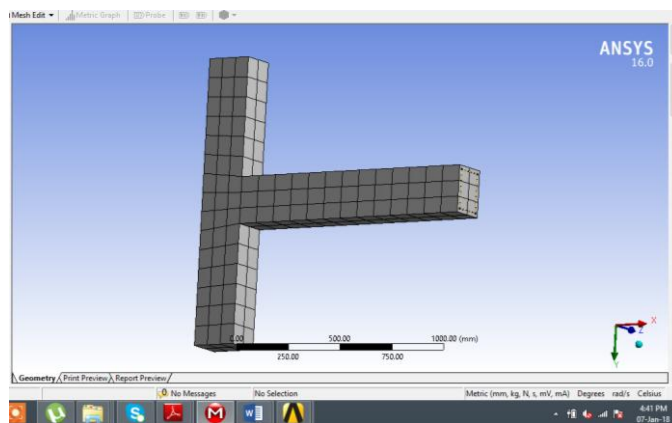

Fig 2.Finite element mesh

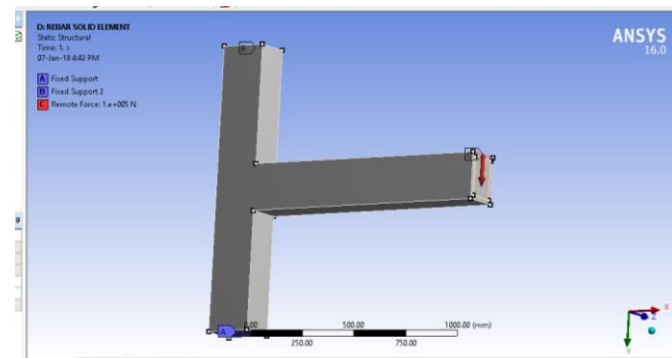

Fig 3.Static Structural Stresses

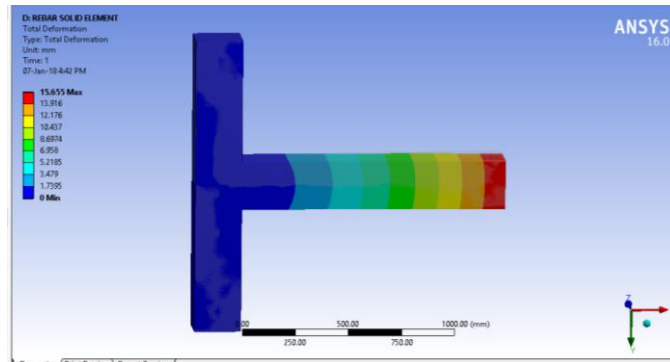

Fig 4.Total Deformation

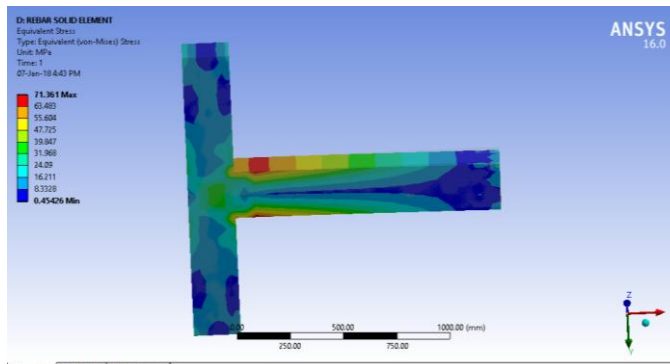

Fig 5.Equivalent Stress

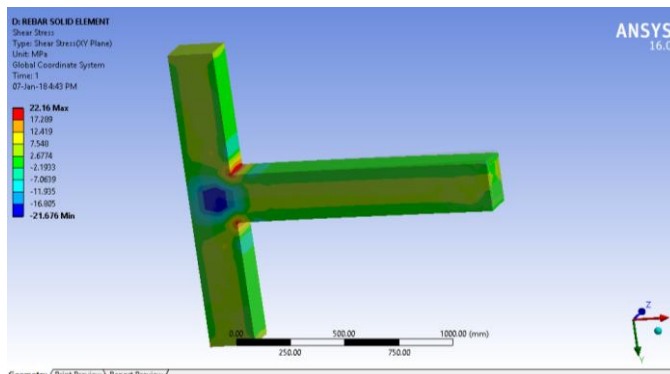

Fig 6.Shear Stress

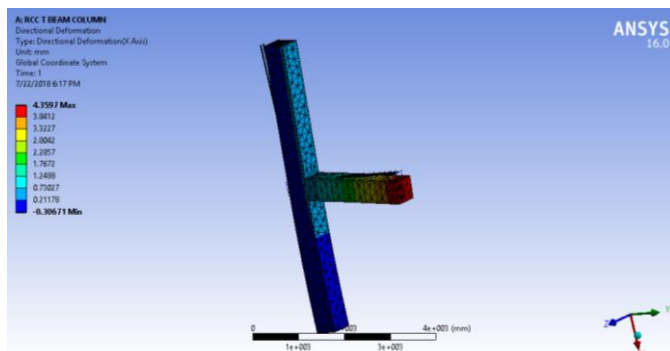

Fig 7.Direction Deformation

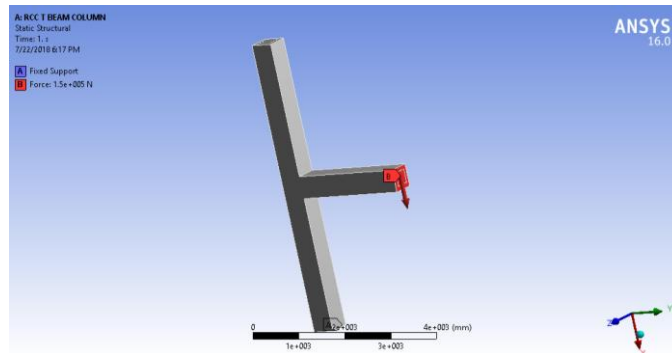

Fig 8 Static structure

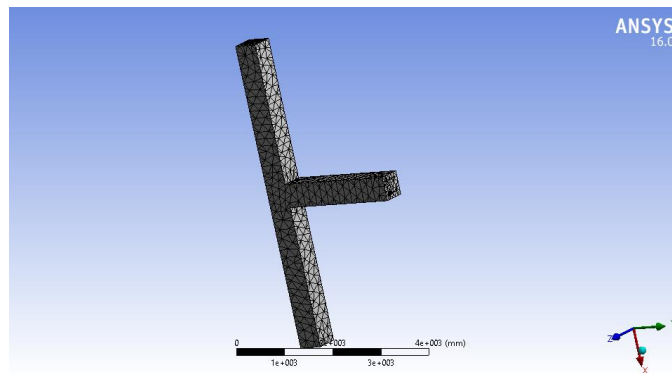

Fig.9. RCC T beam column

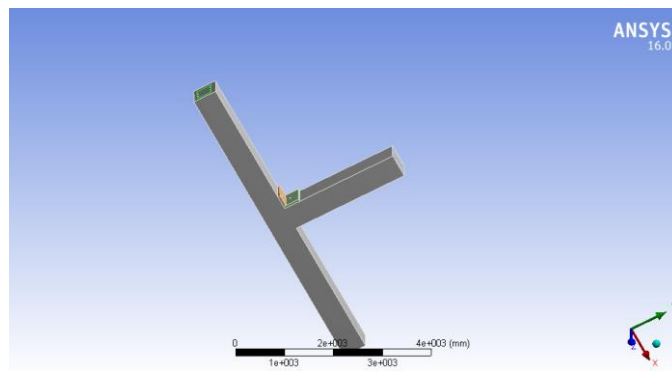
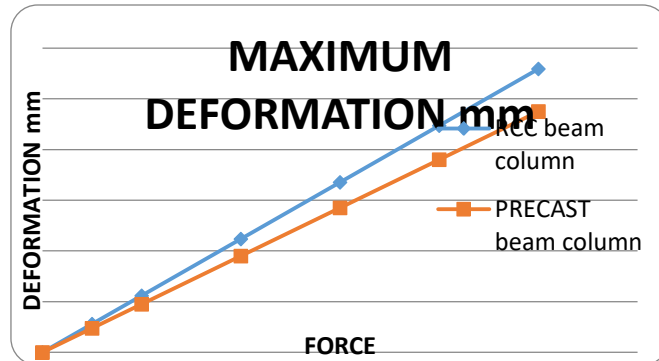

Fig 10: RCC T beam column

MAXIMUM DEFORMATIONM30

MAXIMUM DEFORMATION		
FORCE	RCC beam column	PRECAST beam column
0	0	0.0000
50000	0.1843	0.1456
100000	0.2659	0.2101
200000	0.4934	0.3898
300000	0.7345	0.5803
400000	0.9213	0.7278
500000	1.1895	0.9397



Graph1: MAXIMUM DEFORMATION

NORMAL STRESS M30:

NORMAL STRESS Mpa		
FORCE	RCC beam column	PRECAST beam column
0	0	0
50000	1.9729	1.676965
100000	3.9457	3.353845
200000	7.8915	6.707775
300000	11.837	10.06145
400000	15.783	13.41555
500000	19.729	16.76965

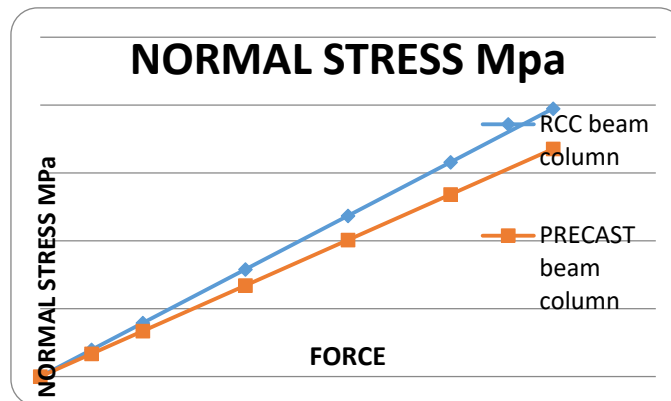

Graph.2: NORMAL STRESS

SHEAR STRESS M30:

SHEAR STRESS Mpa		
FORCE	RCC beam column	PRECAST beam column
0	0	0
50000	2.8298	2.40533
100000	5.6595	4.810575
200000	11.319	9.62115
300000	16.979	14.43215
400000	22.638	19.2423
500000	28.298	24.0533

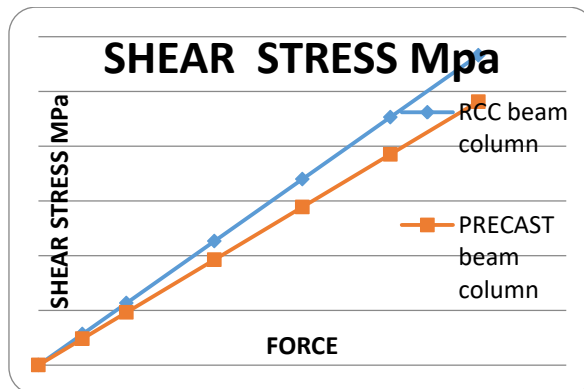

Graph.3: SHEAR STRESS

PRINCIPAL STRESS M30:

MAX. PRINCIPAL STRESS Mpa		
FORCE	RCC beam column	PRECAST beam column
0	0	0
50000	2.012	1.7102
100000	4.0239	3.420315
200000	8.0478	6.84063
300000	12.072	10.2612
400000	16.096	13.6816
500000	20.12	17.102

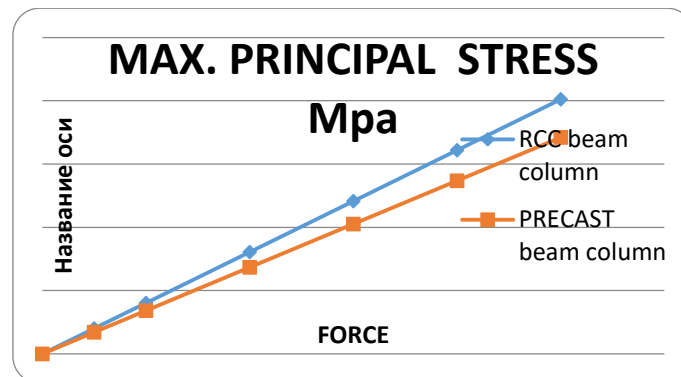

Graph 4: MAX. PRINCIPAL STRESS

VI. CONCLUSION

In this project the comparative analysis is made for RCC and PRECAST beam column connections and following conclusions are observed that

1. The maximum deformation, stress parameters are reduced by 15-20 % in to Precast beam column connections as compared to RCC beam column connections.
2. From the analytical study of the different shape of the beam column connection has been shown that the Precast system is more as compared to RCC.
3. Deformation (Total and Directional) of precast connection system is more than RCC.

For dynamic results the the El Centro data is used after analysis by using ANSYS following conclusion are made

- The total deformation In precast beam columns observed 15 to 20 % less as compared to rcc beam column
- Equivalent Stress In precast beam column is observed 5 to 10 % less as compared to rcc beam column
- Shear Stress In precast beam column is observed 10 to 15 % less as compared to rcc beam column

REFERENCES

1. Hsuan-Teh Hu *, Fu-Ming Lin, Yih-Yuan Jan, ‘nonlinear finite element analysis of reinforced concrete beams strengthened by fiber-reinforced plastics’:2004
2. Sudhakar A. Kulkarni, Bing Li, Woon Kwong Yip, ‘Finite element analysis of precast hybrid-steel concrete connections under’ 7 May 2007:
3. R.A. Hawileh, A. Rahman, H. Tabatabai, ‘Nonlinear finite element analysis and modeling of a precast hybrid beam-column connection subjected to cyclic loads’ 3 December 2009:
4. Ehsan NoroozinejadFarsangi, ‘Connections Behaviour in Precast Concrete Structures
5. Andrei Faur, CălinMircea, MirceaPăstrav ‘A Modeling Technique for Precast Concrete Frames with Hybrid Connections’2012
6. Vidjeapriya. R, Bahurudeen. A, Jaya. K.P ‘Nonlinear analysis of exterior precast beam-column J-Bolt and cleat angle connections’2013
7. T. Subramani, S.Krishnan, M.S.Saravanan, Suboth Thomas, ‘Analysis of Retrofitting Non-Linear Finite Element Of RCC Beam And Column Using Ansys’ 5 December 2014:
8. KarthigaShenbagam.NPreetha.V ‘Finite Element Analysis Of Reinforced Concrete Beams’2014
9. Samir M. O. Hassan Dirar and Chris T. Morley ‘nonlinear finite element analysis of reinforced concrete deep beams’ Feb 2015
10. Paul M. Hopkins, ‘non-linear finite element analysis of frp-precast concrete sandwich panels’ June 2015:
11. TANG Lei‘Nonlinear Finite Element Analysis of New Precast Concrete Shear Wall’ 2015
12. Graham Dean Roberts, Kuinian Li Simplified ‘Nonlinear Analysis of Reinforced Concrete Slabs and Beams’ jan 2016
13. Akash Lanke, Dr. D. Venkateswarlu, ‘Design, Cost & Time analysis of Precast & RCC building’ 06-June-2016: