



e-ISSN: 2319-8753 | p-ISSN: 2347-6710

IJRSET

International Journal of Innovative Research in
SCIENCE | ENGINEERING | TECHNOLOGY

INTERNATIONAL JOURNAL OF INNOVATIVE RESEARCH

IN SCIENCE | ENGINEERING | TECHNOLOGY

Volume 12, Issue 8, August 2023

ISSN INTERNATIONAL
STANDARD
SERIAL
NUMBER
INDIA

Impact Factor: 8.423

9940 572 462

6381 907 438

ijirset@gmail.com

www.ijirset.com

Design and Implementation of ATM Privacy Security and Control System Using IOT

Mr.R,Manikandan, Dr.M.Malarvizhi, Mrs.P.Pushparani,

PG Student, Embedded System Technologies, Gnanamani College of Technology, Namakkal, Tamilnadu, India

Professor, Electrical and Electronic Engineering, Gnanamani College of Technology, Namakkal, Tamilnadu, India.

Assistant Professor, Electrical and Electronic Engineering, Gnanamani College of Technology, Namakkal, Tamilnadu, India

ABSTRACT: Our project suggests a secure ATM (Automated Teller Machine) architecture using a card filtering architecture together with LINK architecture for increased security. Common ATM architectures do not provide the LINK feature for cash withdrawal. In the event that a perpetrator manages to get an ATM card and pin information, he might use it to successfully withdraw fraudulent cash. Therefore, our suggested structure strengthens the LINK framework and the ATM card filtering framework. This client may log in to the framework and filter his card. However, after the customer has completed this confirmation, he may view details before being prompted to input LINK when he selects the cash withdrawal option. The framework creates and transmits a LINK at this point to the client-specific portable number that has been enrolled. The generated advertising is delivered to the client's mobile phone along with the secret word. Now, in order to withdraw money from the framework, he must input the LINK. In this sense, our system provides a two-level security structure for an utterly safe method of doing ATM swaps.

KEYWORDS-IOT,RFID tag and reader, ATM link

I. INTRODUCTION

An implanted framework is a blend of PC equipment and programming, either fixed in capacity or programmable, that is intended for a particular capacity or for explicit capacities inside a bigger framework. Mechanical machines, agrarian and process industry gadgets, vehicles, clinical gear, cameras, family apparatuses, planes, candy machines and toys just as cell phones are largely potential areas for an implanted framework. Implanted frameworks are registering frameworks, yet can extend from having no (UI) - for instance, on gadgets in which the installed framework is intended to play out a solitary undertaking - to complex graphical UIs (GUI, for example, in cell phones. UIs can incorporate catches, LEDs, touchscreen detecting and that's just the beginning. A few frameworks utilize remote UIs too. Inserted frameworks can be chip or microcontroller based. In either case, there is a coordinated circuit (IC) at the core of the item that is commonly intended to complete calculation for continuous activities. Microchips are outwardly unclear from microcontrollers, however while the chip just actualizes a focal preparing unit (CPU) and in this way requires the expansion of different parts, for example, memory chips, microcontrollers are structured as independent frameworks. Installed frameworks can be microchip or microcontroller based. In either case, there is a coordinated circuit (IC) at the core of the item that is commonly intended to complete calculation for ongoing activities. Microchips are outwardly unclear from microcontrollers, however though the chip just actualizes a focal handling unit (CPU) and in this manner requires the expansion of different segments, for example, memory chips, microcontrollers are planned as independent frameworks.

With the advancement of PC organize innovation and internet business, oneself help banking framework has broad promotion with the trademark offering top notch 24 hours administration for client. These days, utilizing the ATM (Automatic Teller Machine) which furnishes clients with the helpful banknote exchanging is normal. Be that as it may, the monetary wrongdoing case rises over and again as of late; a ton of lawbreakers mess with the ATM terminal and take client's charge card and secret word by unlawful methods. When client's bank card is lost and the secret phrase is taken, the criminal will attract all money the most brief time, which will carry gigantic monetary misfortunes to client. The most effective method to carry on the substantial character to the client turns into the concentration in current money related circle. Conventional ATM frameworks confirm for the most part by utilizing the charge card and the secret key, the technique has some defects[4]. Utilizing charge card and secret phrase can't confirm the customer's personality precisely. Any individual who knows the PIN and have the ATM card can without much of a stretch access

the client account. Figure 1. ATM. This paper depicts another strategy consolidating with the customary technique. Here RFID and GSM is utilized to improve the security of the transaction [2][3]. To beat the detriments of embeddings the ATM card into the ATM machine, RFID card is utilized. It peruses the client data by detecting and it additionally oversees various banks accounts in a solitary RFID card. The GSM is utilized to improve the security by giving OTP and furthermore illuminates the client by a SMS on the off chance that the entered secret phrase isn't right.

The Internet of Things (IoT) is a game plan of interrelated handling contraptions, mechanical and automated machines, things, animals or people that are outfitted with exceptional identifiers and the ability to move data over a framework without anticipating that human-should human or human-to-PC affiliation. The IoT is a beast arrangement of related things and people – all of which assemble and offer data about the way in which they are used and about the earth around them. That consolidates a wonderful number of objects of each sort – from splendid microwaves, which normally cook your sustenance for the right timeframe, to self-driving vehicles, whose eccentric sensors separate fights in their way, to wearable wellbeing devices that measure your heartbeat and the amount of steps you've taken that day, by then use that information to prescribe practice plans custom fitted to you. There are even related footballs that can follow how far and brisk they are hurled and record those bits of knowledge by methods for an application for future getting ready purposes.

II. LITERATURE SURVEY

2.1. N. K. Ratha, J. H. Connell, R. M. Bolle Solid client verification is turning into an undeniably significant undertaking in the Web-empowered world. The results of an uncertain verification framework in a corporate or undertaking condition can be disastrous, and may incorporate loss of private data, forswearing of administration, and traded off information trustworthiness. The estimation of solid client verification isn't constrained to simply PC or system get to. Numerous different applications in regular day to day existence likewise require client verification, for example, banking, web based business, and physical access control to PC assets, and could profit by improved security. It is significant that such biometrics-based verification frameworks be intended to withstand assaults when utilized in security-basic applications, particularly in unattended remote applications, for example, web based business. Right now plot the intrinsic qualities of biometrics-based confirmation, distinguish the feeble connections in frameworks utilizing biometrics-based verification, and present new answers for dispensing with a portion of these powerless connections. Despite the fact that, for delineation purposes, unique finger impression confirmation is utilized all through, our investigation reaches out to different biometrics-based techniques.

2.2. Victor Fernandes, Ankita Karia Persuasive Cued Click-Points (PCCP) is a coordinated assessment of the graphical secret key plan, including ease of use and security assessments, and execution contemplations. The methodical assessment gives an extensive and coordinated assessment of PCCP covering both convenience and security issues. A significant ease of use objective for information based confirmation frameworks is to help clients in choosing passwords of higher security, in the feeling of being from an extended viable security space. This exploration work investigates the chance of planning and building a module that is effectively pluggable into the current validation frameworks being utilized starting at now. The working model is an open source reenactment comprising of all the essential modules to fabricate the validation framework. This framework is constructed utilizing Java and Oracle 10g Express Edition as the database albeit most database frameworks can be utilized.

2.3. Yathiraj GR, Santosh VG, Sushma KR, Muthappa KU Old style PIN passage component is extensively utilized for verifying a client. It is a well known plan since it appropriately balances the ease of use and wellbeing parts of a life form. In any case ,on the off chance that this plan is to be utilized in an open framework, at that point the structure may suffer since acknowledge surfing assault. Right now, unapproved client can totally or mostly watch the login session .Even the exercises of the login get-together can be recorded which the aggressor can utilize it not long after to get the real PIN. Right now ,propose a canny UI, known as Color Pass to restrict the acknowledge surfing assault so any real client can enter the session PIN without unveiling the legitimate PIN. The Color Pass depends on a somewhat perceptible aggressor model. The exploratory investigation shows that the Color Pass interface is secure and easy to utilize in any event, for beginner clients

III. EXISTING SYSTEM

The current ATM Simulation System was worked for the first idea of provincial private banks. Little banks in towns and towns will support the necessities of the nearby network and will just expect records to record account subtleties. This framework is inclined to human blunder and makes undue dissatisfaction clients. This framework was expanded

with the presentation of exceed expectations sheets and messages. Banks could now record all data in an exceed expectations sheet and afterward set an update plan when they will mail all records to a focal center point where these records will again be prepared and merged to frame a brought together record of all record exchanges. These frameworks didn't empower simple access to cash and were extraordinarily inclined to unfortunate mistakes.

IV. PROPOSED SYSTEM

The proposed framework intends to understand this by steady refreshing of bank records. The Java based development of the framework will empower exchanges at any bank or ATM to be enlisted inside merely seconds. Security of these subtleties is additionally a top need right now. This focal center point will be gotten to by an ATM for secure client exchanges. In our venture we are going to put an additional catch in ATM machines. At the point when that catch gained squeezed the power window will be broadcasted to bookkeeper mobile phone. At that point the bookkeeper can enter the pin and sum physically in his mobiles broadcasted spring up window. By this control framework bookkeeper can keep his pin number with him and he can distribute the sum by his own control by the ideal individual

4.1 BLOCK DIAGRAM

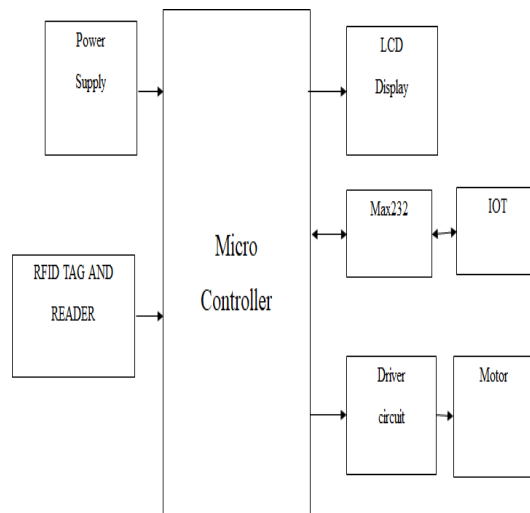

V. SYSTEM REQUIREMENTS

HARDWARE DESCRIPTION

5.1 ARDUINO UNO R3 MICROCONTROLLER

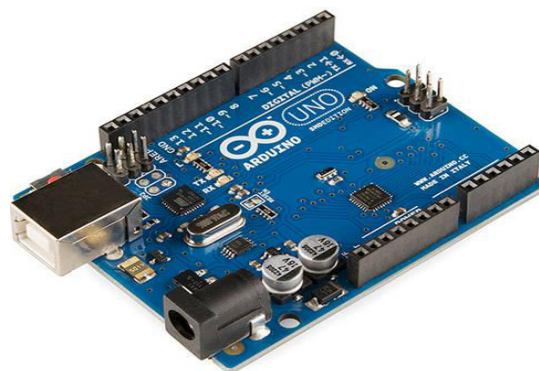

Fig 5.1 Arduino Board

The Arduino Uno R3 is a microcontroller board based on the ATmega328 IC. It has been 14 digital input/output pins (of which 6 can be used as PWM outputs), 6 analog inputs, a 16 MHz crystal oscillator, a USB connection, a power jack, an

ICSP header, and a reset button. It contain everything needed to support the microcontroller; simply connect it to a computer with a USB cable or power it with a AC-to-DC adapter or battery to get started.

5.2 LCD Display



Fig 5.2 LCD

LCD can show numbers, characters and designs. The showcase is interfaced to I/O port of microcontroller (P0.0-P0.7). The presentation is in multiplexed mode . Inside 1/10th of a second the following showcase turns on. there show will bring about constant showcase of tally because of industriousness of Vision.

5.3 MOTOR



Fig 5.3 DC Motor

A DC motor is any of a class of rotary electrical motors that convert direct current electrical energy into mechanical energy. The most common type relies on the forces produced by magnetic fields. Nearly all type of DC motors has some internal mechanism, either electromechanical or electronic, to periodically change the direction of current in part of the motor.

5.4 Power Supply

The AC supply is applied to 12V advance step down transformer. The transformer is the 12V AC which is corrected utilizing a diode connect. The yield of Diode Bridge of 12V DC is separated by capacitor.

5.5 NODE MCU



Fig 5.1 Node MCU

NodeMCU is an open-source Lua based firmware and improvement board uniquely focused on for IoT based Applications. It remembers firmware that runs for the ESP8266 Wi-Fi SoC from Espressif Systems, and equipment which depends on the ESP-12 module.

5.6 RFID Tags

Tags are of two sorts: aloof labels which have no battery life and dynamic labels which have battery life. RFID labels discharged for naturally distinguishing an individual, a bundle or a things. These are transponders that transmit data. RFID tag contains two sections. One is coordinated circuit for regulating, putting away and preparing data and demodulating radio recurrence (RF) signal. The second is a reception apparatus for accepting and transmitting signal.

5.7 RFID Reader

RFID reader comprises of a RF module that goes about as a transmitter and beneficiary of radio recurrence signal. Transmitter comprises of an oscillator to make the transporter recurrence; a modulator to have effect on information directions upon this bearer signal and a beneficiary that contains demodulator to separate the information returned.

VI.CONCLUSION

This entire execution guarantees us a made sure about and verified exchange through RFID and GSM procedure with most reduced expense and least upkeep. Humanity will use new and made sure about sort of cash exchanges. Interestingly, introductory expense of RFID change of the whole framework is the necessary one time venture. The worth included assistance that this framework gives builds the validity of the budgetary establishments, the banks improves the comfort to its client. Consequently as the world advances through the unavoidable and a dauntless journey for information, the part of security bound frameworks will undoubtedly yield with the developing advancements and clearly more vulnerabilities. Consequently our application may well comprehend the part of exchange security to an exact and extraordinary degree.

REFERENCES

- [1] G.Udaya Sree, M.Vinusha “ Real Time SMS-Based Hashing Scheme for Securing Financial Transactions on ATM Terminal” ,*IJSETR*, ISSN 2319-8885 Vol.02,Issue.12, September-2013, Pages:1223-1227.
- [2] Khatmode Ranjit P, Kulkarni Ramchandra V, “ARM7 Based Smart ATM Access & Security System Using Fingerprint Recognition & GSM Technology”, ISSN 2250-2459, ISO 9001:2008 Certified Journal, Volume 4, Issue 2, February 2014.
- [3] M.R.Dineshkumar,M.S.Geethanjali,“Protected Cash Withdrawal in ATM Using Mobile Phone”, *International Journal Of Engineering And Computer Science* ISSN:2319-7242 Volume 2 Issue 4 April, 2013 Page No. 1346-1350.
- [4] Zaid Imran,Rafay Nizaami ,”Advance Secure Login”, *International Journal For Science and Research Publications*, Volume 1,Issue 1,December 2011.
- [5] M. Ajaykumar and N. Bharath Kumar,” Anti-Theft ATM Machine Using Vibration Detection Sensor”, *IJARCSSC* Volume 3, Issue 12, December 2013 ISSN: 2277 128X.
- [6] SURAJ B S and Dr. R GIRISHA, “ ARM7 based Smart ATM Access System”, *International Journal on Recent and Innovation Trends in Computing and Communication* ISSN: 2321-8169 Volume: 3 Issue: 5.
- [7] K.annan K, “Microcontroller Based Secure Pin Entry Method For ATM”, *International Journal of Scientific & Engineering Research*, Volume 4, Issue 8, August-2013 ISSN 2229-5518.
- [8] Hyung-Woo Lee,“Security in Wireless Sensor Networks: Issues and Challenges”, *ICACT*, ISBN 89-5519-129-4, Feb. 20-22, 2006.



INNO SPACE
SJIF Scientific Journal Impact Factor
Impact Factor: 8.423



ISSN INTERNATIONAL
STANDARD
SERIAL
NUMBER
INDIA



INTERNATIONAL JOURNAL OF INNOVATIVE RESEARCH

IN SCIENCE | ENGINEERING | TECHNOLOGY

9940 572 462 **6381 907 438** **ijirset@gmail.com**



www.ijirset.com

Scan to save the contact details