



e-ISSN: 2319-8753 | p-ISSN: 2347-6710

IJRSET

International Journal of Innovative Research in
SCIENCE | ENGINEERING | TECHNOLOGY



INTERNATIONAL JOURNAL OF INNOVATIVE RESEARCH

IN SCIENCE | ENGINEERING | TECHNOLOGY

Volume 13, Issue 7, July 2024

ISSN INTERNATIONAL
STANDARD
SERIAL
NUMBER
INDIA

Impact Factor: 8.423

9940 572 462

6381 907 438

ijirset@gmail.com

www.ijirset.com

Autonomous Mini Unmanned Ground Vehicle for Disaster Monitoring and Surveillance

Vijesh K¹, Abhinand M Shibu², Arun K³, Nidhun V P⁴, Vismaya K S⁵

Assistant Professor, Department of Computer Science and Engineering, NSS College of Engineering, Palakkad,
Kerala, India¹

U.G. Student, Department of Computer Science and Engineering, NSS College of Engineering, Palakkad,
Kerala, India^{2 3 4 5}

ABSTRACT: In this ground breaking project, we are improving our fire intensity monitoring rover, powered by a Raspberry Pi and a camera module, by incorporating obstacle avoidance and semi-autonomous capabilities. The primary goal of the rover is to travel to fire-prone areas while gathering live feeds for transmission to a central server, allowing for real-time monitoring and analysis. Ultrasonic sensors ensure obstacle avoidance, boosting adaptability across varied terrains. The rover's movements can be directed remotely using a user-friendly Flask-powered web app via a PC or smartphone. The camera module collects live fire pictures, which are then processed by the Raspberry Pi to analyze intensity and spread, resulting in visualizations that may be used to make any decision during firefighting efforts. With a rechargeable battery pack for extended operation, this adaptable rover demonstrates the viability of using Raspberry Pi-based systems. The rover's utility extends beyond fire monitoring to search and rescue missions, negotiating tough terrain independently. The camera module detects life indications, while a built-in loudspeaker allows survivors to communicate and receive important information. This project demonstrates the adaptability of Raspberry Pi-based systems by presenting a flexible solution for fire monitoring and response that integrates obstacle avoidance and semi-autonomous capabilities, ultimately contributing to the reduction of fire-related dangers to life and property.

I. INTRODUCTION

This paper introduces a specialized fire-detecting rover designed to elevate fire monitoring capabilities in challenging environments. Traditionally, fire detection methods relying on human patrols or stationary monitoring systems face limitations in coverage, speed, and real-time data collection. In response, our rover is equipped with advanced sensors, cameras, and cutting-edge technologies to autonomously or remotely identify and monitor fires across diverse terrains. The integration of ultrasonic sensors ensures obstacle avoidance, enhancing adaptability in challenging environments. The semi-autonomous capabilities of the rover enable efficient navigation, making it an ideal solution for inaccessible areas. Facilitating early fire detection, the rover captures live feeds of fires using a camera module and transmits this vital information wirelessly to a central server for real-time monitoring and analysis. Powered by a Raspberry Pi, the rover's core processing unit analyzes fire intensity and spread, generating visualizations to inform decisionmaking in firefighting efforts. The incorporation of a Flask-powered web app allows for intuitive remote control, enabling users to direct the rover's motion through laptops or smart phones. Beyond fire detection, the rover extends its utility to search and rescue operations, autonomously navigating rough terrain and leveraging the camera module to detect signs of life. With a built-in loudspeaker, the rover facilitates communication with survivors, showcasing its multifunctional capabilities in diverse emergency response scenarios. In summary, our fire-detecting rover project represents a significant advancement in fire monitoring technology, addressing the limitations of traditional methods and contributing to the reduction of risks and damages associated with fires across a spectrum of environments.

Paper is organized as follows. Section II describes automatic text detection using morphological operations, connected component analysis and set of selection or rejection criteria. The flow diagram represents the step of the algorithm. After detection of text, how text region is filled using an Inpainting technique that is given in Section III. Section IV presents experimental results showing results of images tested. Finally, Section V presents conclusion.

II. RELATED WORK

View finder:Robotic Assistance to fire fighting services and Management[1] The view finder project integrates behavior-based navigation (BBN) to enhance the capabilities of the robots. BBN is a control architecture that combines sensing, reasoning, and actuation to enable effective navigation and task performance. This approach aims to create a coherent framework for the robots to perform tasks adequately, combining the advantages of reactive and planner-based approaches. Software model for robot programming and example of implementation for navigation system[2] This paper proposed a software model to address the problem and resolve the current challenges in developing robotic software systems. With the help of the proactive engine, the proposed software system has both powers of object oriented principles and rule-based systems. A Multimodal AI Framework for Hyper Automation in Industry 5.0[3] The architecture of innovative technologies called hyper automation is utilized to scale an organization's automation capabilities. Integrating ROS and Android for Rescuers in a Cloud Robotics Architecture:[4]

Application to a Casualty Evacuation Exercise The content focuses on the UMAROS- Android app for cloud robotics in disaster response,enabling communication and data sharing between responders and a mission control center.It highlights the integration of UGVs with rescue teams for casualty evacuation missions, with a case study conducted in Malaga, Spain in June 2022.The methodology emphasizes the adaptability of navigation modes for UGVs and the usability of the app in demanding environments. OS based Autonomous Mobile Robot Navigation using 2D LiDAR and RGB-D Camera[5] System implementation is based on basic ROS navigation stack. In any case, during an investigation, depth information requires high processing time and bandwidth. Study of ROS Based Localization and Mapping for Closed Area Survey[6] The paper explores the efficiency of survey robots in closed areas using Turtlebot 3 and ROS.The Laser Scanner was used for detecting the environment around the survey robot and the GMapping algorithm in ROS was used to generate the map. The experiment has surveying and generating a map, and using the SLAM algorithm to identify the movement of the survey robot. ROS based Autonomous Mobile Robot Navigation using 2D LiDAR and RGB-D Camera[7] System implementation is based on basic ROS navigation stack. In any case, during an investigation, depth information requires high processing time and bandwidth depth information requires high processing time and bandwidth.

III. EXISTING METHODOLOGY

We have integrated the creative approaches and design ideas of the ROMR (ROS-based Open-source Mobile Robot) effort into our own mobile robotics platform, as a result of our project's insightful analysis of it. The ROMR project's focus on accessibility and cost-effectiveness has had a special impact on our methodology. Through the utilization of additive manufacturing technology and readily available electronic components, we have been able to decrease the total cost of our platform without compromising its functionality or performance. This is in line with the goal of the ROMR, which is to offer an open-source, low-cost substitute for mobile robotics applications. This will help us create a system that is both technically sound and commercially viable. Furthermore, the ROMR project's utilization of the Robot Operating System (ROS) has inspired our software architecture development. By adopting similar principles and leveraging the capabilities of ROS, we have been able to enhance the adaptability and interoperability of our platform, ensuring seamless integration with existing robotic systems and facilitating the development of advanced functionalities. This strategic alignment with ROS, as demonstrated by the ROMR project, has proven instrumental in streamlining our software development process and optimizing the overall performance of our mobile robotics platform. Apart from taking cues from the software techniques and design of the ROMR project, we have also evaluated our platform in comparison with the salient characteristics

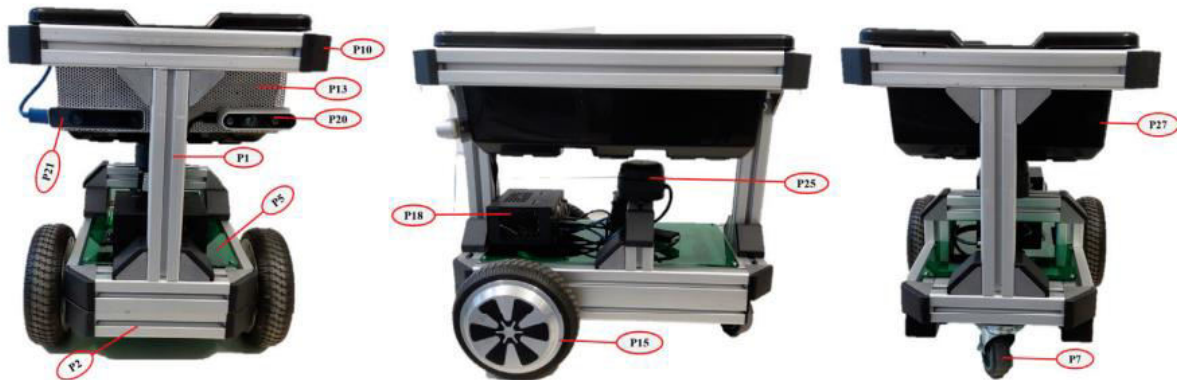

FIGURE 3.1: ROMR

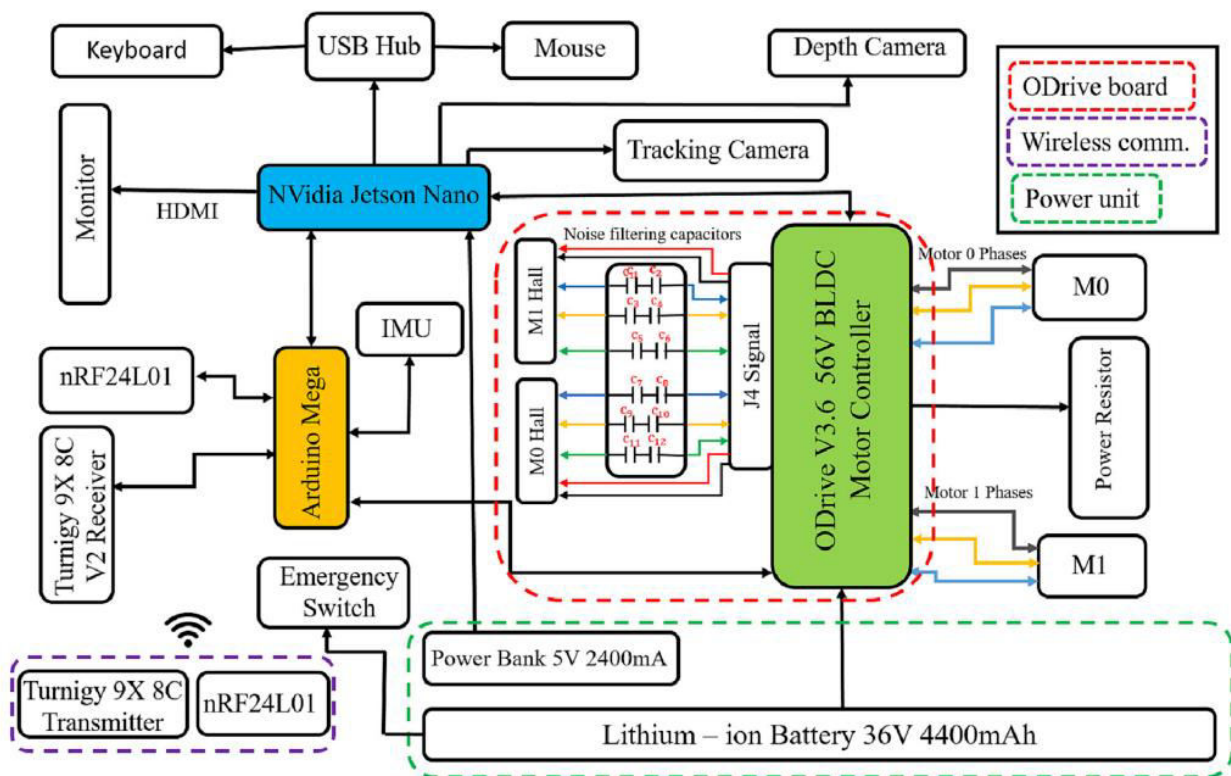

Figure 3.2: ROMR Hardware Architecture[1]

platform in terms of cost-performance, load carrying capability, and compatibility with ROS thanks to this thorough evaluation. We have gained important insights into the key components of an open-source, low-cost mobile robotics solution by matching our evaluation criteria with those in the ROMR paper. This has allowed us to make sure our platform satisfies the rigorous requirements for successful deployment in.

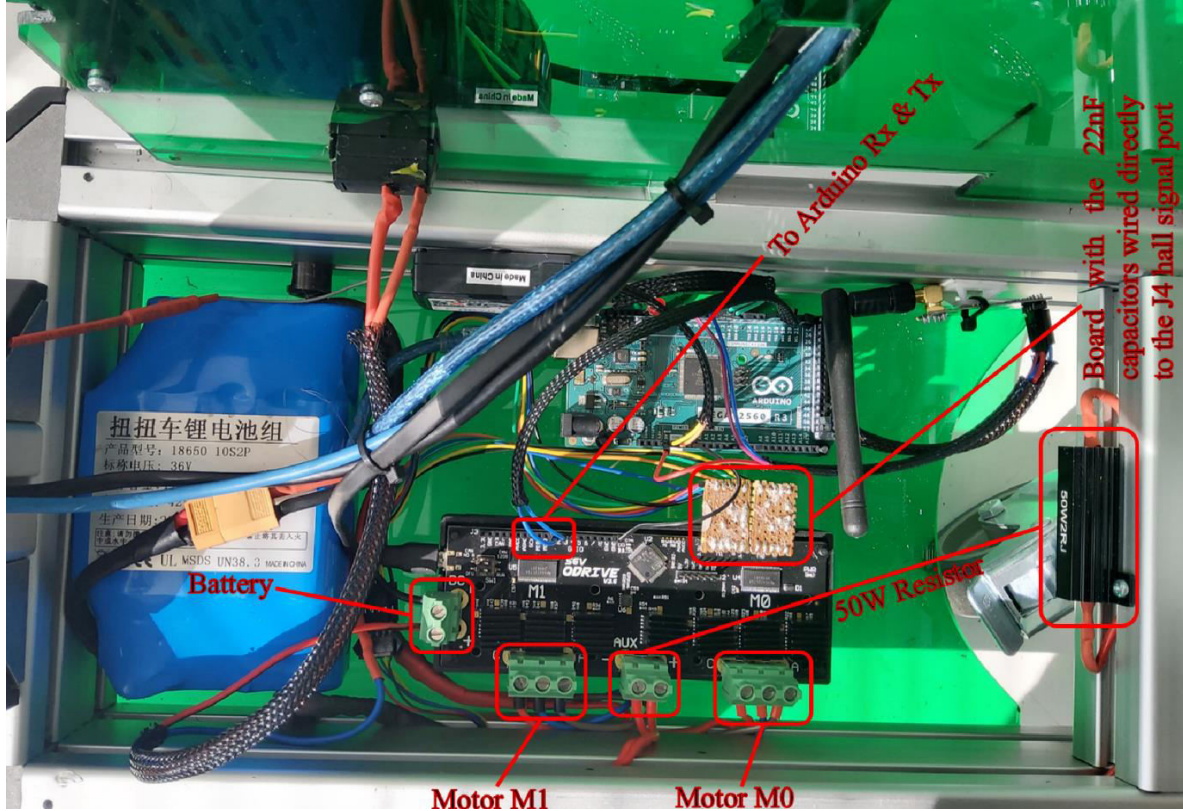

Figure 3.3: Internal Wiring ROMR[1]

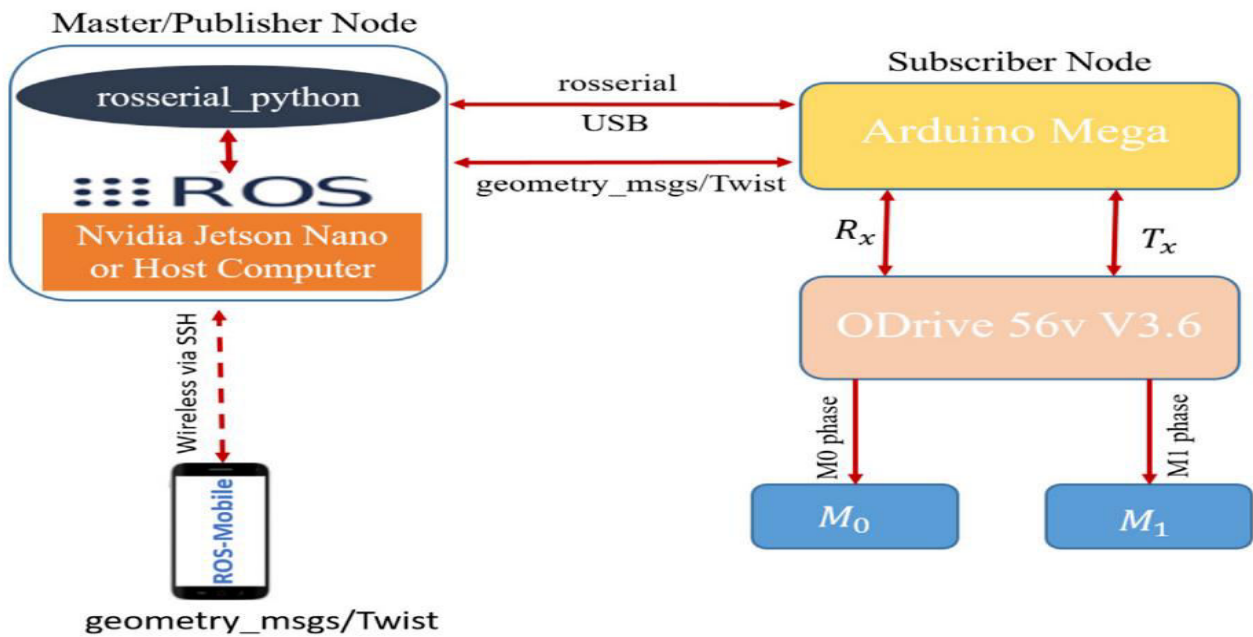

Figure 3.4: System Communication Structure[1]

IV. COMPLETE IMPLEMENTATION

The project's main prototype, a state-of-the-art obstacle avoidance robot, has made significant progress throughout its partial implementation phase. This phase's cornerstone was the painstaking building of a Manual Ground Vehicle (MGV), an essential forerunner to the semi-autonomous rover. The MGV's sturdy chassis and integrated motor controls were purposefully meant to serve as the cornerstone upon which the rover's sophisticated features could be assembled. The MGV's sophisticated camera visualization system's effective integration was a notable achievement during this time. In addition to offering real-time visual feedback, this connection paves the way for the rover's semi-autonomous capabilities. The camera visualization system creates a vital connection between the robotic control system and the actual environment, while also improving the robot's ability to perceive its surroundings. The robot's decision making mechanisms benefit greatly from this visual feedback, especially when it comes to detecting and avoiding obstacles. The concept has moved beyond theory and become a working prototype thanks to the smooth integration of the camera visualization system with the MUGV. This milestone highlights the project's viability and potential effect by signaling a critical shift from conceptualization to real implementation. With this strong base in place, the project's later stages will benefit from additional developments in autonomous functionality and improved obstacle recognition algorithms, which should enable the robot to achieve even greater feats of capability. The project is headed toward a promising future with the successful partial implementation, as it positions itself to offer a smart and fully functional semi-autonomous robot. The visual is sent to the raspberry pi which is then processed by the fire detection model that has been trained with the dataset that has both with fire and no fire images, also tested with the same type of dataset. After the processing the model gives out the output as fire or no fire

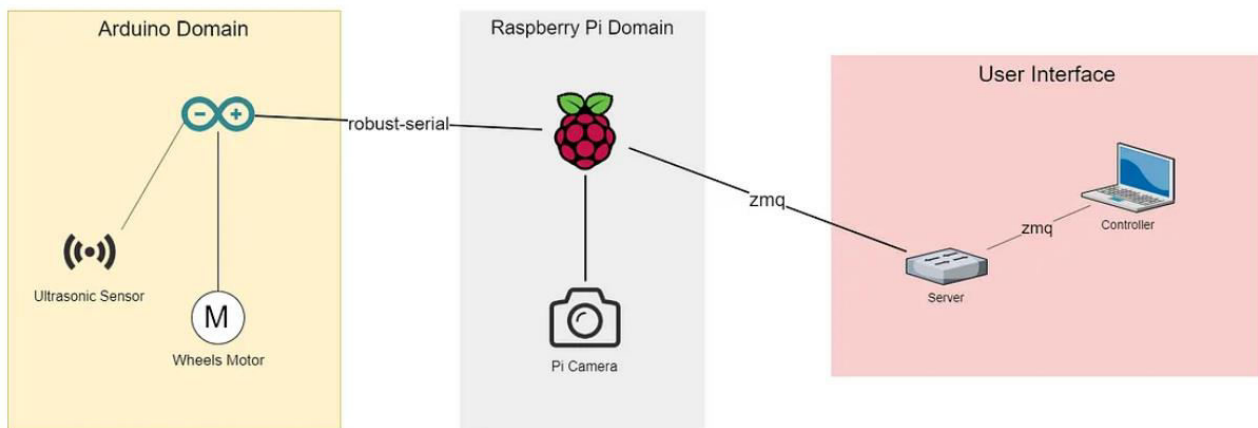

Figure 4.1: Architecture Overview

V. TOOLS SPECIFICATION

5.1 Python

Python is the programming language mostly used in this research due to its rich ecosystem of libraries and versatility. Python is a great choice to implement the pipeline components for classifying hate speech because of its broad community support and ease of use. Python has libraries specially designed for projects related to NLP, deep learning and machine learning. Libraries like scikit-learn, TensorFlow, Keras, and gensim provide robust functionality for text analysis, model development, and data preprocessing—all necessary steps in hate speech parsing Python's syntax and readability for its simple and easy for novice and experienced developers to use. The ease of use allows for rapid testing and prototyping and speeds up the reproduction of pipeline designs. Python's dominance in the hate speech classification industry is strengthened by its extensive libraries, community support, and compatibility with data processing tools in addition to user-friendly terminology This flexibility for researchers and developers can efficiently develop, test and repair samples.

5.2 Numpy

A vast set of high-level mathematical functions to operate on huge, multi-dimensional arrays and matrices, as well as support for these arrays, are provided by the NumPy library for the Python programming language. We can expedite our workflow and integrate with other programs in the Python ecosystem, such as scikit-learn, that leverage NumPy internally, by utilizing NumPy

5.3 Pandas

Pandas serve as a pivotal tool in the hate speech classification pipeline, particularly for managing datasets structured in a tabular format. Its rich functionalities empower efficient data handling, preprocessing, and exploration, streamlining the critical data preparation phase. Through Pandas, data cleaning becomes more intuitive, allowing for the removal of duplicates, handling missing values, and formatting columns for better compatibility with machine learning models. The library's transformation capabilities facilitate feature engineering, enabling the creation of new meaningful features from existing data. Additionally, Pandas' descriptive statistics and visualization tools aid in exploring data distributions and identifying patterns, providing invaluable insights that inform subsequent modeling decisions. Overall, Pandas' versatility and ease of use significantly expedite the initial stages of the hate speech classification process, laying a solid foundation for subsequent model development and training.

5.4 Computer Vision

Computer vision is a dynamic field within artificial intelligence focused on enabling machines to interpret and understand visual data. It involves the development of algorithms and systems that empower computers to extract meaningful information from images or video streams. Tasks include image recognition, object detection, and scene understanding. Leveraging techniques like image processing, machine learning, and neural networks, computer vision finds applications in diverse industries. This technology plays a pivotal role in healthcare for medical image analysis, aids autonomous vehicles in navigation and object detection, enhances retail processes through automated checkout and inventory management, and contributes to surveillance systems for security monitoring. The rise of deep learning, particularly convolutional neural networks, has significantly boosted computer vision capabilities by allowing machines to automatically learn intricate representations of visual data. As computer vision progresses, it not only refines existing applications but also unlocks novel possibilities, bridging the gap between the digital and physical worlds through intelligent visual perception.

5.5 TensorFlow lite

TensorFlow Lite (TFLite) represents a significant leap forward in machine learning (ML) deployment, tailored for mobile and embedded devices. Developed by Google as an extension of TensorFlow, TFLite addresses challenges in running ML models efficiently on resource-constrained platforms. It optimizes models for execution on devices like smartphones, IoT devices, and microcontrollers by reducing size, memory footprint, and computational overhead. This enables real-time inference even without extensive GPU support, making it ideal for edge computing scenarios. TFLite's advantages lie in its efficiency, low latency, and offline capability. It minimizes inference latency, supports offline inference, and integrates seamlessly with mobile development frameworks. This versatility enables a range of applications, from image recognition and language processing in mobile apps to edge computing solutions in IoT and industrial automation. However, challenges such as model optimization and accuracy trade-offs persist, highlighting ongoing areas of research and development in the ML community. The future of TFLite holds promise in improving model compression techniques, expanding hardware support, and enhancing developer tools for better integration and performance tuning. As demand grows for intelligent, responsive applications across diverse domains, TFLite continues to evolve, democratizing AI capabilities and paving the way for a more connected, intelligent future powered by mobile machine learning.

5.6 ROS2

ROS 2, the Robot Operating System 2, represents a significant evolution in the field of robotics and automation. Developed as the successor to ROS, ROS 2 introduces several improvements and features that enhance its usability, scalability, and performance in diverse robotic applications. This essay explores the key aspects of ROS 2, including its architecture, advantages, challenges, applications, and future developments, highlighting its role in shaping the future of robotics and automation. ROS 2 adopts a modular and distributed architecture, leveraging DDS (Data Distribution Service) middleware for communication. This architecture enables better scalability, real-time capabilities, and support for multi-robot systems compared to its predecessor. Key features of ROS 2 include improved message serialization, support for real-time systems, more robust security features, and enhanced interoperability with non-ROS systems.

These features make ROS 2 well-suited for complex robotics applications in industrial automation, autonomous vehicles, and collaborative robotics. ROS 2 offers several advantages over ROS, making it a preferred choice for modern robotics development. Its improved communication infrastructure ensures better reliability and performance in large-scale systems. ROS 2's support for realtime capabilities expands its use cases to safety-critical applications such as robotic surgery and autonomous driving. Furthermore, ROS 2's compatibility with industry standards and protocols facilitates seamless integration with existing automation systems, making it a versatile platform for a wide range of applications in robotics research, manufacturing, logistics, and healthcare. While ROS 2 brings significant advancements, it also faces challenges such as transitioning from ROS 1, learning curve for developers, and maintaining compatibility with existing ROS packages. However, the ROS community actively addresses these challenges through documentation, tutorials, and migration tools. Future developments in ROS 2 are expected to focus on improving real-time performance, enhancing developer experience, expanding hardware support, and fostering collaboration with industry partners to drive innovation in robotics and automation. ROS 2 represents a major step forward in robotics software frameworks, offering enhanced capabilities, scalability, and real-time support for diverse robotic applications. Its adoption continues to grow in research, academia, and industry, driving innovation and enabling the development of advanced robotic systems. As ROS 2 matures and addresses its challenges, it is poised to play a pivotal role in shaping the future of robotics and automation, contributing to safer, smarter, and more efficient robotic systems across various domains.

5.7 Raspberry pi 4B

The Raspberry Pi is a versatile and affordable single-board computer that has garnered widespread popularity for its capability to serve various purposes in the realm of computing and electronics. Developed by the Raspberry Pi Foundation, it's a credit card-sized device that boasts powerful features despite its small size and low cost. Equipped with various models offering different specifications, it typically includes components like USB ports, HDMI output, GPIO pins for interfacing with external devices, Ethernet connectivity, and WiFi/Bluetooth capabilities, providing a solid foundation for diverse projects. Its accessibility and ease of use make it an ideal choice for hobbyists, educators, and professionals exploring fields like programming, robotics, home automation, and even as a platform for IoT applications. Users can run various operating systems, primarily Linux-based. The Raspberry Pi can be used as a bridge between a USB camera and an Arduino Mega for live video feed and signaling. For the video feed, the Raspberry Pi can receive video data from a USB camera using software like Motion1. This software monitors the video signal from the camera and can detect if a significant part of the picture has changed, essentially detecting motion1. For signaling to the Arduino Mega, the Raspberry Pi can communicate with the Arduino using serial communication over a USB cable2. The Raspberry Pi can send commands to the Arduino, and the Arduino can send data back to the Raspberry Pi2. For example, the Raspberry Pi could send a command to the Arduino to activate a motor or read sensor data 2.

5.8 Arduino mega

The Arduino Mega is a multipurpose microcontroller board with improved functionality. compared to the standard Arduino boards. Featuring the ATmega2560 microcontroller at its core, the Arduino Mega is equipped with a greater number of digital I/O pins (54 in total, of which 15 can be used for PWM output) and analog inputs (16 analog inputs). This abundance of I/O options makes the Mega well-suited for complex and larger-scale projects requiring multiple sensors, actuators, displays, and communication interfaces. With 256 KB of flash memory, 8 KB of SRAM, and 4 KB of EEPROM, the Mega provides ample space for storing code and data. It also supports various communication protocols such as UART, SPI, and I2C, facilitating connectivity with a wide range of devices. The Arduino Mega is compatible with the Arduino IDE and shields designed for the Mega, enabling users to quickly prototype and develop projects requiring extensive I/O capabilities, making it an excellent choice for robotics, automation, 3D printers, and other sophisticated applications. The Arduino Mega is a multipurpose microcontroller board with improved functionality. in contrast to the typical Arduino boards. With the ATmega2560 microcontroller at its heart, the Arduino Mega has more digital I/O pins—54 total—than other microcon- trollers. where by sixteen (16 analogue inputs) and fifteen (15 PWM output units) can be utilised. This plenty The Mega's range of I/O choices makes it ideal for intricate and substantial projects needing many displays, actuators, sensors, and interfaces for communication. 256 KB of flash memory With 8 KB of SRAM and 4 KB of EEPROM for memory, the Mega offers plenty of room for storing data and code. Additionally, it supports a number of communication protocols, including SPI, I2C, and UART enabling. The Arduino Mega acts as the brain of the robot, controlling all other components and making decisions based on the input it receives. The robot uses an HC-SR04 Ultrasonic Sensor to detect obstacles by sending out ultrasonic waves and measuring the time it takes for the waves to bounce back after hitting an obstacle. This time is then used to calculate the distance to the obstacle. The ultrasonic sensor is mounted on a servo motor, allowing the sensor to look around for

obstacles. If an object is detected within 15 centimeters, the robot stops, looks around, and moves in a direction where it doesn't sense anything. The robot's speed and direction are controlled by four DC motors, which are in turn controlled using an L298 DC motor driver. The driver can rotate the motors in a clockwise or anti-clockwise direction, allowing the robot to move straight, turn right, or turn left. The robot works by continuously scanning its surroundings with the ultrasonic sensor. If it detects an obstacle, it stops, looks for a clear path, and then moves in that direction. The process can be described with a simple pseudocode that includes functions to measure distance with the ultrasonic sensor, stop the motors, check if the left and right are clear, turn left, turn right, turn around, and move forward. These functions would need to be implemented in your Arduino code.

5.9 Motor Driver L298n

The L298N is a widely used motor driver integrated circuit (IC) known for its versatility and reliability in robotics and electronics projects. Its primary function is to control the direction and speed of DC motors and stepper motors. With bidirectional control, it can drive motors forward or backward based on the control signals provided. One of its key advantages is its high current capability, typically handling up to 2A per channel continuously and up to 3A for short durations. This feature makes it suitable for driving a wide range of motors, including those with higher power requirements. Additionally, the L298N includes built-in diodes to protect against back electromotive force (EMF), safeguarding the circuit from potential damage. The ease of use of the L298N is another notable benefit. It requires minimal external components for basic operation and can be easily interfaced with microcontrollers or other control systems. Its compatibility with various microcontrollers, such as Arduino and Raspberry Pi, enhances its versatility for different types of projects. Despite its capabilities, the L298N remains compact in size, making it suitable for projects where space is limited. Moreover, it is relatively affordable compared to other motor driver solutions, which makes it accessible for hobbyists, students, and professionals alike.

The L298N supports multiple operating modes, including full-step, half-step, and microstepping modes for stepper motor control, providing flexibility in motor control applications. Overall, its simplicity, reliability, and capability to drive a wide range of motors make the L298N a popular choice across various domains.

5.10 Gas Sensor MQ135

The MQ135 gas sensor is a commonly used component in various applications where the detection of certain gases is necessary. Its primary function is to detect a wide range of gases, including ammonia, nitrogen oxides, benzene, alcohol, smoke, and carbon dioxide. This versatility makes it valuable in applications such as air quality monitoring, safety systems, industrial processes, and environmental monitoring. One of the key advantages of the MQ135 sensor is its sensitivity to a variety of gases at concentrations as low as parts per million (ppm). This sensitivity enables early detection of potentially harmful gases in the environment, allowing for timely intervention and preventive measures. Additionally, the sensor provides real-time data, enabling continuous monitoring of gas levels for prompt response to any changes or anomalies. Another advantage of the MQ135 sensor is its compact size and ease of integration into electronic systems. It typically comes in a small package and requires minimal external components for operation, making it suitable for integration into portable devices, IoT (Internet of Things) applications, and wearable technology. Its low power consumption further enhances its suitability for battery-powered applications. Furthermore, the MQ135 sensor is cost-effective compared to some other gas detection technologies, making it accessible for hobbyists, educators, and small-scale projects. Its affordability, combined with its reliability and versatility, has contributed to its widespread adoption in both educational and industrial settings.

In summary, the MQ135 gas sensor offers a valuable combination of sensitivity, versatility, compactness, and affordability, making it an essential component in various gas detection and monitoring applications. Its ability to detect multiple gases at low concentrations in real-time enables timely response to environmental changes, ensuring safety, and enhancing efficiency in a wide range of scenarios.

5.11 Ultrasonic Sensor HC-SR04

The HC-SR04 ultrasonic sensor is a widely utilized component in the field of electronics and robotics, valued for its ability to accurately measure distance using ultrasonic waves. Its primary function is to emit ultrasonic pulses and then calculate the time taken for these pulses to bounce back after hitting an object. This time measurement allows the sensor to determine the distance between itself and the object, making it suitable for various applications requiring distance sensing and obstacle avoidance. One of the key advantages of the HC-SR04 sensor is its high accuracy in distance measurement, typically with an error margin of just a few millimeters. This level of precision enables precise

navigation and obstacle avoidance in robotics and autonomous systems. Additionally, the sensor's wide detection range, which can extend from a few centimeters to several meters depending on the model, offers flexibility in accommodating diverse application requirements. Another advantage of the HC-SR04 sensor is its ease of use and integration into electronic circuits. It typically operates on a simple principle, requiring only a few GPIO (General Purpose Input/Output) pins for interfacing with microcontrollers or other control systems. Moreover, it comes in a compact and lightweight package, making it suitable for integration into small-scale projects, drones, robotic vehicles, and IoT devices. Furthermore, the HC-SR04 sensor is cost-effective compared to some other distance sensing technologies, making it accessible for hobbyists, educators, and small-scale projects with budget constraints. Its affordability, combined with its reliability and ease of use, has contributed to its widespread adoption in both educational and industrial settings. In summary, the HC-SR04 ultrasonic sensor offers a valuable combination of high accuracy, wide detection range, ease of use, and affordability, making it an essential component in various distance sensing and obstacle avoidance applications. Its ability to provide precise distance measurements in real-time enables efficient navigation and control in robotics, automation, and IoT systems, enhancing their functionality and usability.

5.12 DC Gear Motor 12v 60 rpm

The DC gear motor, specifically the 12V 60 RPM variant, is a widely used component in robotics, automation, and various electromechanical systems. Its primary purpose is to convert electrical energy from a direct current (DC) power source into mechanical energy, providing rotational motion at a controlled speed and torque output. The 12V rating indicates the voltage required to operate the motor, while the 60 RPM (revolutions per minute) specification denotes its rotational speed. One of the key advantages of the DC gear motor, especially the 12V 60 RPM model, is its high torque output relative to its size and power consumption. The gearing mechanism coupled with the motor allows for a significant increase in torque compared to a standard DC motor, making it suitable for applications requiring higher levels of torque, such as driving wheels in robotic platforms or conveyor systems. Another advantage of the DC gear motor is its versatility and ease of integration into various mechanical designs. Its compact size and lightweight construction make it suitable for use in constrained spaces or applications where weight is a concern. Additionally, the motor can be easily coupled with other mechanical components, such as wheels, pulleys, or gears, to create complex motion systems tailored to specific application requirements. Furthermore, the 12V operating voltage of the motor provides compatibility with a wide range of power sources, including batteries, power supplies, and renewable energy systems. This flexibility in power input allows for seamless integration into both portable and stationary applications, such as mobile robots, solar trackers, and automated machinery. Moreover, the DC gear motor offers precise speed control and directionality, allowing for accurate positioning and motion control in various automation tasks. Its ability to maintain a constant speed and deliver consistent torque output enhances the performance and reliability of the systems in which it is employed. In summary, the DC gear motor, particularly the 12V 60 RPM variant, offers a valuable combination of high torque, compact size, versatility, and precise control, making it an essential component in a wide range of electromechanical applications. Its ability to convert electrical energy into controlled mechanical motion enables efficient and reliable operation in robotics, automation, and other motion control systems.

VI. RESULTS

The link between memory accuracy and confidence is depicted by the recall confidence curve. Accuracy first improves with more confidence. But there comes a moment at which more confidence breeds overconfidence or false recall, which reduces accuracy. Finding the right balance between accuracy and confidence in memory or retrieval processes is crucial. The trade-off between recall and precision in a binary classification model is displayed by the precision-recall curve. It performs poorly as seen by its limited recall and precision at first. Precision improves as recollection rises. On the other hand, precision can decrease if recollection is increased even higher. High recall and precision are the optimum conditions. The precision-recall trade-off can be made and the model's performance better understood with the aid of the curve. The precision-confidence curve illustrates how a prediction system's precision varies with confidence levels. Initially, precision is typically low when there is little confidence. Precision improves with increasing confidence, suggesting a higher percentage of actual positive predictions. Knowing this curve makes it easier to set appropriate thresholds and strike a balance between system confidence and precision. The accuracy of a system or process varies with confidence levels, as seen by the confidence curve. Initially, accuracy is typically low when confidence is low. Accuracy improves with increased confidence, suggesting a greater chance of making accurate judgments or predictions. We can better adjust our confidence levels and strike

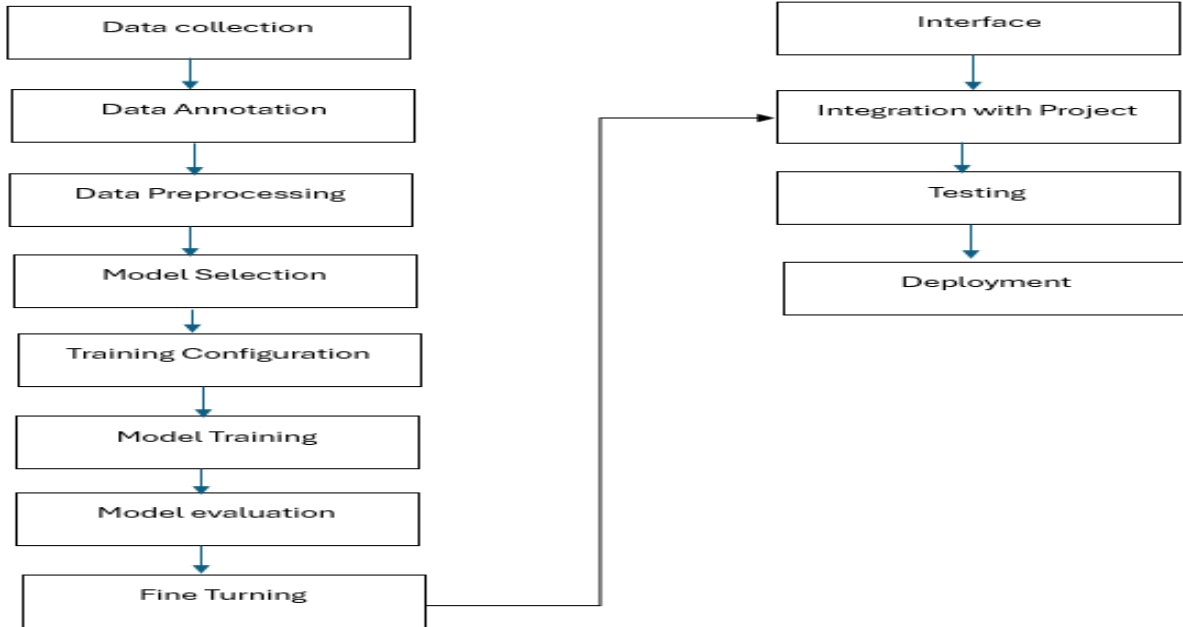

Figure 6.1: Object Detection Dataflow

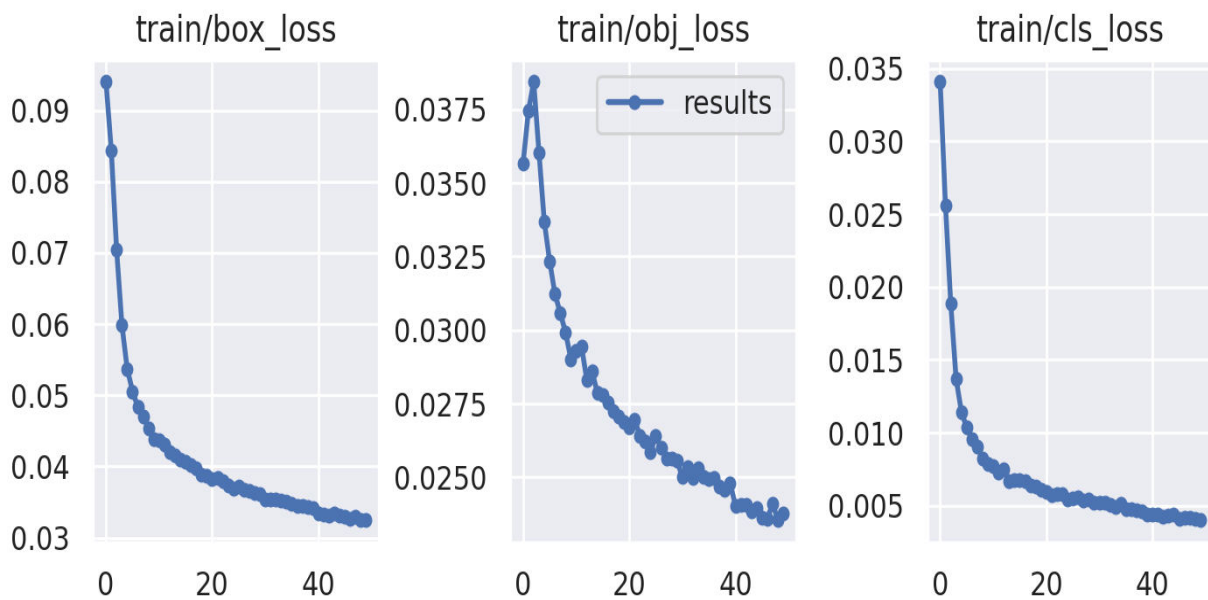

Figure 6.2: training efficiency 1

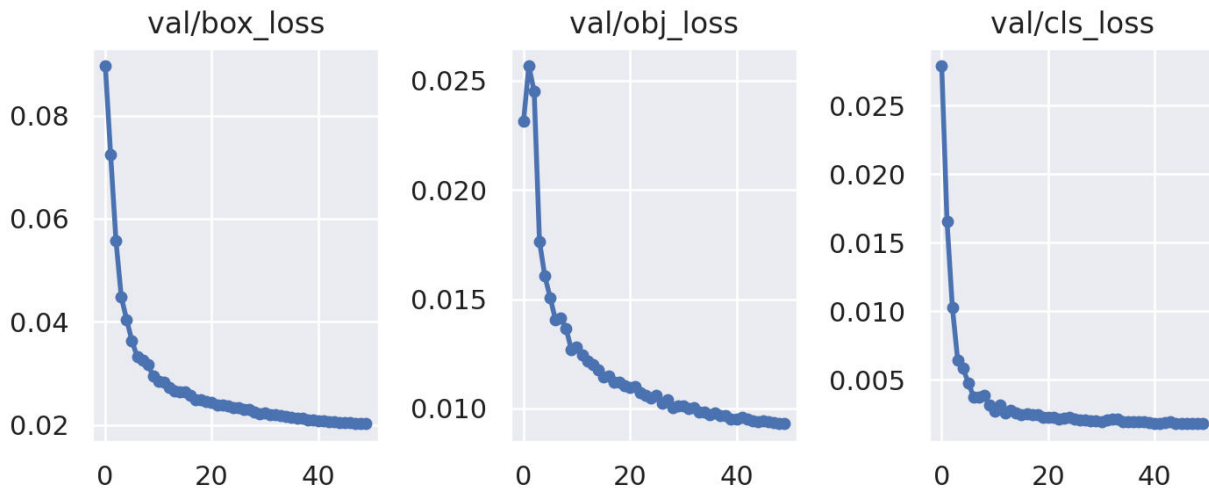

FIGURE 6.3: TRAINING EFFICIENCY 2

the ideal balance between accuracy and confidence by having a thorough understanding of this curve. The names or symbols of the variables under analysis should be represented as labeled variables on the x- and y-axes of the correlogram. Furthermore, the correlation coefficients ought to be labeled within the correlogram's cells using symbols or numerical values that indicate the strength of the correlation. Included should be a color key or legend that explains the significance of the various hues or intensity levels for correlation strength. A title stating the correlogram's goal and any appropriate captions or descriptions might be added to improve clarity and comprehension. For objects in the output to be correctly identified and localized, these labels are essential. While the width label helps interpret the spatial properties and scale of the discovered objects, the instance label guarantees unique item identification. When combined, these labels provide YOLO's output with a complete depiction of the items it has observed. A tabular representation known as a confusion matrix is used to compare the predicted labels of a classification model with the actual labels in order to summarize the model's performance. It has four labels: False Positives (FP) for erroneous positive predictions, False Negatives (FN) for erroneous negative predictions, and True Positives (TP) for right positive forecasts. The matrix sheds light on the kinds of errors the model makes and how accurate it is. It facilitates the computation of numerous assessment measures, including F1 score, accuracy, precision, and recall, allowing for a thorough evaluation of the model's classification performance. These graphs show the convergence and performance of the YOLO model and offer insights into the training process. They support the identification of patterns, evaluation of overfitting or underfitting, and modification of the training procedure for best outcomes.

6.1 Designs

We are currently halfway through the development of our Mini Unmanned Ground Vehicle (UGV) and are fully engaged in an innovative design journey. With the powerful features of Fusion 360, our team has painstakingly created a one-of-a-kind UGV design from the ground up. We have been able to achieve a harmonious fusion of form and function by seamlessly integrating hardware and software components thanks to Fusion 360's prowess as a 3D modelling software. The halfway point represents not only a step towards completion but also an iterative refinement phase where the digital blueprint is being adjusted to better suit practical needs. Our dedication to iterative processes is fundamental to our design philosophy. This continuous improvement guarantees that the UGV's structure will always be flexible enough to accommodate a wide range of scenarios. Though originally conceived, the digital design is evolving to represent adaptability, user-friendliness, and a smooth integration of independent systems. Our dedication to expanding the bounds of design excellence is based on this iterative methodology. A pivotal element of our Mini UGV's design that sets it apart is the revolutionary track wheel system. Departing from conventional wheeled designs, the track wheels are proving to be a game-changer in terms of mobility, stability, and adaptability across varied terrains. Early testing indicates that the unique design significantly enhances traction on challenging surfaces, providing stability and reliability in diverse environmental conditions. The UGV's track wheels facilitate agile maneuvering, allowing it to navigate tight spaces and execute precise turns – a crucial attribute for applications ranging from exploration in

confined environments to surveillance in complex urban landscapes. As we move into the second half of our UGV development, the track wheel system is the focus of ongoing testing and improvement. We will simulate real-world scenarios and a variety of terrains to thoroughly assess the system’s performance. Our iterative approach guarantees that the design quickly incorporates lessons learned from testing, pushing the track wheels—an the UGV as a whole—to a level of mobility and adaptability that surpasses initial expectations. As we continue to explore the boundaries of design innovation, keep an eye out for more updates. With a commitment to design excellence and creative mobility solutions, the Fusion 360-designed Mini UGV project promises to set new standards in unmanned ground vehicle capabilities. Moving forward, we are still working to perfect the track wheel system and incorporate refinements based on ongoing testing. The ultimate goal is to not only meet but exceed the demands of autonomous mobility across diverse environments

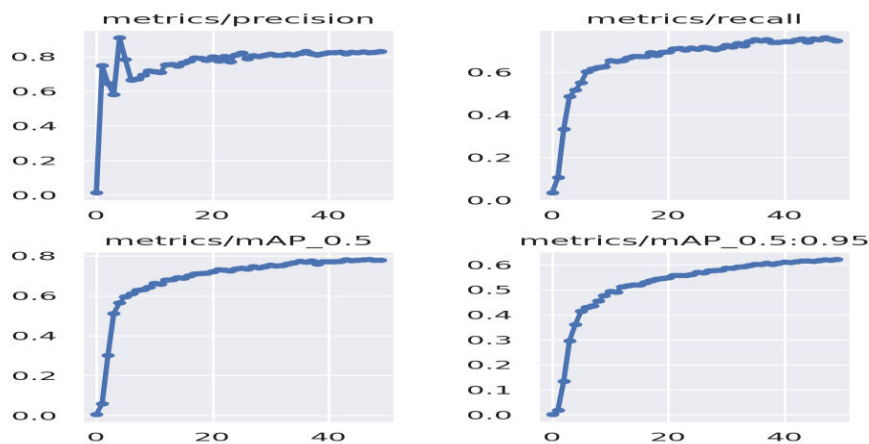

Figure 6.4: training efficiency 3

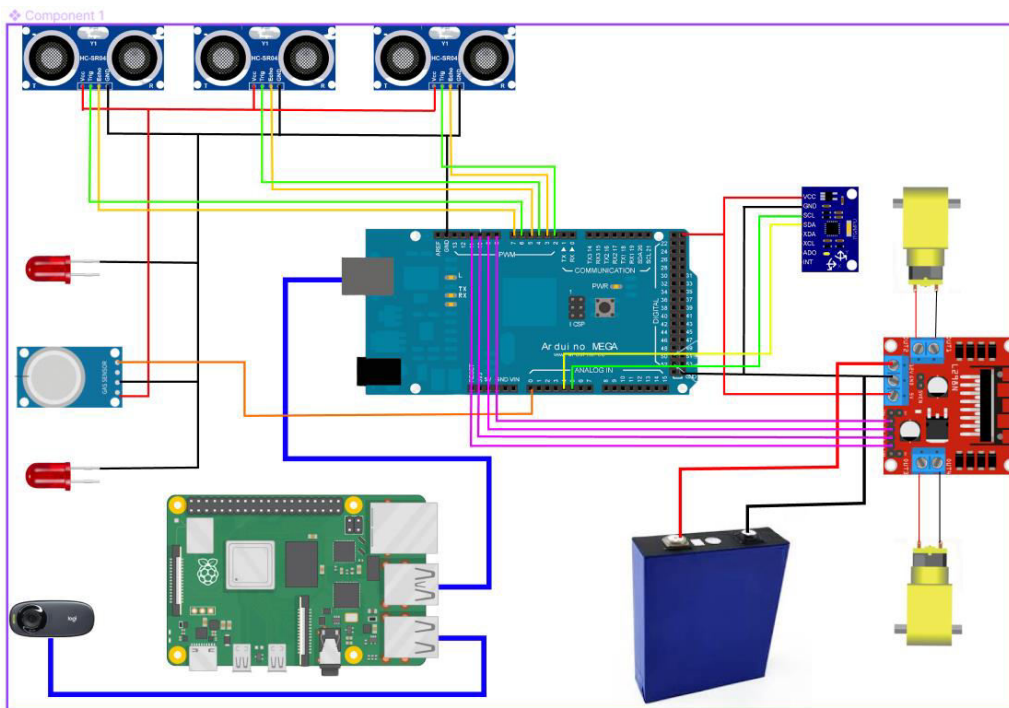

Figure 6.5: circuit diagram

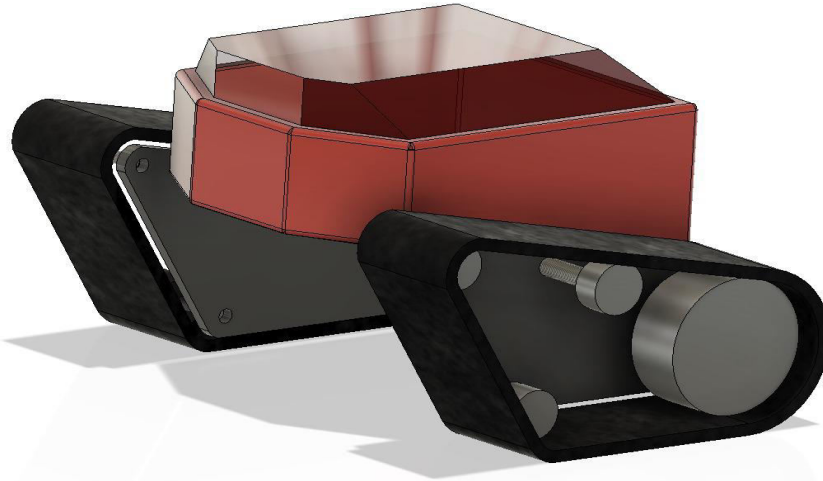

Figure 6.6: Autonomus MUGV Design

VII. CONCLUSION

In summary, our obstacle avoidance robot prototype has seen a revolutionary development during the partial implementation phase. Two noteworthy accomplishments that firmly establish the movement from ideation to concrete realisation are the building of the Manual Ground Vehicle (MGV) and the smooth integration of a camera visualisation system. This stage has demonstrated the project's potential for real-world use while also providing a solid basis for the semi-autonomous rover. Looking ahead, future research will concentrate on two important areas to improve the robot's capabilities. First off, a more complex and flexible control architecture will be made possible by the integration of the Robot Operating System (ROS), which will be a crucial step. With the help of ROS, the robot will be able to communicate more effectively and integrate different sensors and actuators more easily, making the system smarter and more flexible overall. Essentially, the next step in the development of our obstacle avoidance robot is represented by the integration of ROS and the use of a metal-sealed body. These upcoming projects should improve the robot's functionality, dependability, and performance, establishing it as a viable option for a range of real-world applications. We are convinced that these improvements will advance our project towards the creation of a fully functional and significant autonomous obstacle avoidance robot as we move forward with the next stages of development. In essence, the integration of ROS and the use of a metal-sealed body represents the next step in the evolution of our obstacle avoidance robot. These future endeavours are expected to improve the robot's performance, reliability, and versatility, establishing it as a viable solution in a variety of real-world scenarios. As we move forward, we are confident that these improvements will propel our project towards the realisation of a fully functional and impactful autonomous obstacle avoidance robot.

REFERENCES

- [1] Linus, N., Clemens, F., Bartsch, K., Rueckert, E. (2023). ROMR: A ROS-based open-source mobile robot. *HardwareX*, 14, e00426. <https://doi.org/10.1016/j.ohx.2023.e00426>
- [2] S. Gatesichapakorn, J. Takamatsu and M. Ruchanurucks, "ROS based Autonomous Mobile Robot Navigation using 2D LiDAR and RGB-D Camera," 2019 First International Symposium on Instrumentation, Control, Artificial Intelligence, and Robotics (ICA-SYMP), Bangkok, Thailand, 2019, pp. 151-154, doi: 10.1109/ICA-SYMP.2019.8645984.
- [3] YoonSeok Pyo, HanCheol Cho, RyuWoon Jung, TaeHoon Lim, "ROS RobotProgramming," Republic of Korea, ROBOTIS Co.,Ltd, 2017
- [4] X. Ao et al., "Road Recognition and Stability Control for Unmanned Ground Vehicles on Complex Terrain," in *IEEE Access*, vol. 11, pp. 77689-77702, 2023, doi: 10.1109/ACCESS.2023.3297511.

- [5] B. L. E. A. Balasuriya et al., "Outdoor robot navigation using Gmapping based SLAM algorithm," Moratuwa Engineering Research Conference (MERCon), Moratuwa, 2016, pp. 403-408.
- [6] Baudoin, Yvan Doroftei, Daniela De Cubber, Geert Berrabah, Sid Ahmed Colon, Eric Pinzón, Carlos Maslowski, Andrzej Bedkowski, Janusz Penders, Jacques. (2009). VIEW-FINDER : Robotics Assistance to fire-Fighting services.
- [7] S. Chaychi, D. Zampunieris and S. Reis, "Software Model for Robot Programming and Example of Implementation for Navigation System," 2023 9th International Conference on Automation, Robotics and Applications (ICARA), Abu Dhabi, United Arab Emirates, 2023, pp. 75-79, doi: 10.1109/ICARA56516.2023.10125856.
- [8] S. D, B. A, K. TR, S. k. D, S. V and J. L. N, "A Multimodal AI Framework for Hyper Automation in Industry 5.0," 2023 International Conference on Innovative Data Communication Technologies and Application (ICIDCA), Uttarakhand, India, 2023, pp. 282-286, doi: 10.1109/ICIDCA56705.2023.10099581.
- [9] M. Toscano-Moreno et al., "Integrating ROS and Android for Rescuers in a Cloud Robotics Architecture: Application to a Casualty Evacuation Exercise," 2022 IEEE International Symposium on Safety, Security, and Rescue Robotics (SSRR), Sevilla, Spain, 2022, pp. 270-276, doi: 10.1109/SSRR56537.2022.10018629.
- [10] S. Gatesichapakorn, J. Takamatsu and M. Ruchanurucks, "ROS based Autonomous Mobile Robot Navigation using 2D LiDAR and RGB-D Camera," 2019 First International Symposium on Instrumentation, Control, Artificial Intelligence, and Robotics (ICA-SYMP), Bangkok, Thailand, 2019, pp. 151-154, doi: 10.1109/ICA-SYMP.2019.8645984.
- [11] S. Oajsalee, S. Tantrairatn and S. Khaengkarn, "Study of ROS Based Localization and Mapping for Closed Area Survey," 2019 IEEE 5th International Conference on Mechatronics System and Robots (ICMSR), Singapore, 2019, pp. 24-28, doi: 10.1109/ICMSR.2019.8835455.
- [12] S. Gatesichapakorn, J. Takamatsu and M. Ruchanurucks, "ROS based Autonomous Mobile Robot Navigation using 2D LiDAR and RGB-D Camera," 2019 First International Symposium on Instrumentation, Control, Artificial Intelligence, and Robotics (ICA-SYMP), Bangkok, Thailand, 2019, pp. 151-154, doi: 10.1109/ICA-SYMP.2019.8645984.



INTERNATIONAL
STANDARD
SERIAL
NUMBER
INDIA



INTERNATIONAL JOURNAL OF INNOVATIVE RESEARCH

IN SCIENCE | ENGINEERING | TECHNOLOGY

 9940 572 462  6381 907 438  ijirset@gmail.com



www.ijirset.com

Scan to save the contact details