



e-ISSN: 2319-8753 | p-ISSN: 2347-6710

# IJRSET

International Journal of Innovative Research in  
**SCIENCE | ENGINEERING | TECHNOLOGY**



# INTERNATIONAL JOURNAL OF INNOVATIVE RESEARCH

IN SCIENCE | ENGINEERING | TECHNOLOGY

Volume 13, Issue 11, November 2024

**ISSN** INTERNATIONAL  
STANDARD  
SERIAL  
NUMBER  
INDIA

**Impact Factor: 8.524**

 9940 572 462

 6381 907 438

 [ijirset@gmail.com](mailto:ijirset@gmail.com)

 [www.ijirset.com](http://www.ijirset.com)

# Geometric Modelling and Structural Analysis of Surface Condenser Equipment

Dr. A. B. Vinayaka Patil<sup>1</sup>, Dr. T N Vijay Kumar<sup>2</sup>, Dr. Prashanth Banakar<sup>3</sup>

Assistant Professor, Department of Mechanical Engineering, Bapuji Institute of Engineering and Technology,  
Davanagere, Karnataka, India<sup>1</sup>

Assistant Professor, Department of Mechanical Engineering, Bapuji Institute of Engineering and Technology,  
Davanagere, Karnataka, India<sup>2</sup>

Principal, Jain College of Engineering and Technology, Hubballi, Karnataka, India<sup>3</sup>

**ABSTRACT:** In any power plant apart from the turbine, boiler and pump, the condenser is a vital component. Condensers are important heat and mass exchange apparatus in oil refining, chemical engineering, environmental protection, electric power generation, etc. Among different types of condensers, shell and tube condensers have been commonly used in industries. Nearly 35–40% of heat exchangers are of the shell and tube type and this is primarily due to the robust construction geometry, easy maintenance and possible upgrades of shell and tube condenser. The main considerations in the design of a condenser for a particular application are stresses and displacements due to the design pressure and temperature, design for manufacture, physical size and cost. In this dissertation work the condenser is analysed for static and thermal loading. The geometric model of the condenser is created using CATIA Software as per the drawings supplied. This model is imported to HYPERMESH through IGES format and then meshed appropriate with shell and solid elements. The mesh convergence is achieved by changing element edge lengths by checking aspect ratio, quad deviation, Jacobian and included angles. The finite element model of condenser is subjected to design pressure, hydro test pressure, full Vacuum, and thermal loads. One of the supporting legs is constrained in all the degrees of freedom and the other one is constrained only in Z- direction and restriction of rotation. All these are imposed using HYPERMESH and it is exported to ANSYS for solution. The deflections and stresses were computed by doing static analysis. The results of displacements and stresses obtained are compared with the allowable limits suggested as per the ASME section VIII Division 2. The details of analysis and results along with discussions are available in this work.

**KEYWORDS:** Surface Condenser, hydrostatic pressure, Vacuum Pressure, HYPERMESH, CATIA, Rankine cycle.

## I. INTRODUCTION

A steam condenser is a device or an appliance in which steam condenses and heat released by steam is absorbed by water. It serves the following purposes: It maintains a very low back pressure on the exhaust side of the piston of the steam engine or turbine. Consequently, the steam expands to a greater extent which results in an increase in available heat energy for converting into mechanical work. The thermal efficiency of a condensing unit therefore is higher than that of non-condensing unit for the same available steam. It supplies to the boiler pure and hot feed water as the condensed steam which is discharged from the condenser and collected in a hot well, can be feed water for the boiler.

**The Rankine Cycle:** The Rankine cycle is the standard for steam power plants that are built around the world. The basic Rankine cycle consists of four main components such as Steam Generator, Turbine, Steam Condenser and Pump as shown in Fig.1.

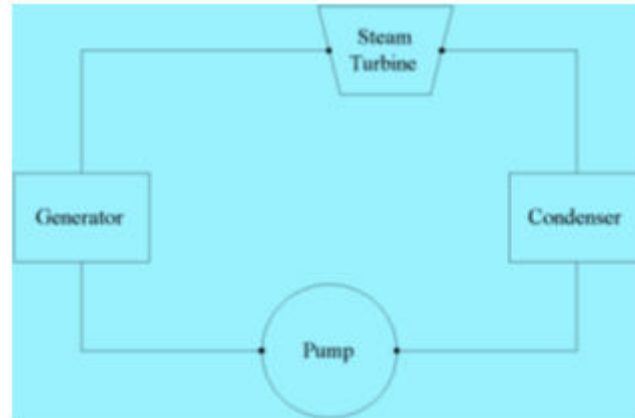

Fig. 1 Rankine cycle

The actual Rankine cycle used in modern power plants has many more components, but the above four components are common to all power plants. In this cycle, water is heated in the steam generator to produce high temperature and pressure steam. This steam is then expanded in a turbine to produce electricity from a generator that is connected to the turbine. The steam from the turbine is then condensed back into water in the condenser. The pump then returns the water to the steam generator.

Thus, the main purposes of the condenser are to condense the exhaust steam from the turbine for reuse in the cycle and to maximize turbine efficiency by maintaining proper vacuum. As the operating pressure of the condenser is lowered (vacuum is increased), the enthalpy drop of the expanding steam in the turbine will also increase. This will increase the amount of available work from the turbine (electrical output). By lowering the condenser operating pressure, the following will occur: Increased turbine output, Increased plant efficiency, Reduced steam flow (for a given plant output) It is therefore very advantageous to operate the condenser at the lowest possible pressure (highest vacuum).

The Condensers are of two types: Jet condensers and Surface condensers. In jet condensers, the exhaust steam and water come in direct contact with each other and temperature of the condensate is the same as that of cooling water leaving the condenser. The cooling water is usually sprayed into the exhaust steam to cause, rapid condensation. In surface condensers, the exhaust steam and water do not come into direct contact. The steam passes over the outer surface of tubes through which a supply of cooling water is maintained. There may be single pass or double pass. In single pass condensers, the water flows in one direction only through all the tubes, while in two pass condenser the water flows in the direction through the tubes and returns through the remainder. A jet condenser is simpler and cheaper than a surface condenser. It should be installed when the cooling water is cheaply and easily made suitable for boiler feed or when a cheap source of boiler and feed water is available. A surface is most commonly used because the condensate obtained is not shown as a waste but returned to the boiler.

## II. LITERATURE SURVEY

Condensers are important heat and mass exchange apparatus in oil refining, chemical engineering, environmental protection, electric power generation etc. Among different types of condenser, shell and tube condenser have been commonly used in industries [1]. Master et al, [2] indicated that more than 35–40% of heat exchangers are of the shell and tube type, and this is primarily due to the robust construction geometry as well as easy maintenance and possible upgrades of shell and tube condenser. They are widely used as evaporators and condensers. The heat transfer effectiveness of shell and tube condenser can be improved by using baffles. Segmental baffles are most commonly used in conventional shell and tube condenser to support tubes and change fluid flow direction. Segmental baffles cause the shell-side fluid to flow in a tortuous, zigzag manner across the tube bundles, which can enhance the heat transfer on the shell side. However, there exist many problems associated with the use of segmental baffles [3–5]. 1. High pressure drop on the shell side due to the sudden contraction and expansion of the flow in the shell side, and the fluid impinging on the shell walls caused by segmental baffles; 2. Low heat transfer efficiency due to the flow stagnation in the so-called “dead zones,” which are located at the corners between baffles and

shell wall; 3. Low shell-side mass velocity across the tubes due to the leakage between baffles and shell walls caused by inaccuracy in manufacturing tolerance and installation; 4. Short operation time due to the vibration caused by shell-side flow normal to tube banks. When the traditional segmental baffles are used in shell and tube condenser, higher pumping power is often needed to offset the higher pressure drop under the same heat load. Therefore, it is essential to develop a new type of shell and tube condenser using different type of baffles to have higher heat transfer efficiency and lower pressure drop.

The concept of shell and tube condenser with baffles has been discussed by several researchers [6–12]. The baffles in shell and tube condenser are shaped approximately as helicoids in order to have the fluid flow in the shell side close to continuous flow, which will result in a decrease in pressure drop and an increase in heat transfer in the shell side of the heat exchanger. Productions of shell and tube condenser with helical baffles started in 1990s. At present, this type of shell and tube condenser is used in many countries, such as USA, Russia, and Japan. Up to now, nearly all baffles used in shell and tube condenser are non-continuous approximate helicoids due to difficulty in manufacturing [13]. Generally, non-continuous baffles are made by four elliptical sector-shaped plates joined end to end. Elliptical sector-shaped plates are arranged in a pseudo helical non-contiguous baffle system. Each baffle occupies one-quarter of the cross section of the heat exchanger and is angled to the axis of the heat exchanger. The inter space between the two sector plates, which is so-called triangle region, leads to great fluid leakage [14]. Therefore, the flow in the shell side is not exactly the perfect flow. This will result in a decrease in heat transfer on the shell side of the heat exchanger. Moreover, the fluid flow in the shell side of shell and tube condenser becomes more complicated due to the flow leakage in the “triangle region” if non-contiguous baffles are used. Block plates can be used to block the flow leakage in this region. However, this will result in difficulty in manufacturing and significant increase in flow resistance. It is clear that the use of continuous baffles in shell and tube condenser can improve their performance. However, very few research works on shell and tube condenser using continuous baffles have been reported in open literature.

### 2.1 Objectives of the present work:

In any design problem the output of the design depends on the input given i.e., the design parameters, which affects the design adversely and some of the definitions are to be mentioned clearly. The unambiguous definition of the problem makes the designer work easy. Probably the most critical step in the design process is the definition of the problem. The true problem is not always what it seems to be at first glance because this first step requires such a small part of the total time to create the final design, its importance is often overlooked. This work deals with the design of the condenser which are mostly used in many areas like power plants, refrigerating plants, aerospace, etc., the condenser which is designed and analyzed is been used in a Power Plant.

Objectives of the present work are:

- To create geometric model of the condenser by using high end solid modelling software CATIA as per drawings supplied.
- To create finite element model of the condenser by using the HYPERMESH software.
- Static analysis of the condenser is to be carryout using the ANSYS software.

In this design, it is expected that condenser should withstand the pressure as well as temperature load conditions.

## III. METHODOLOGY

### Solid Modelling of the Condenser:

Solid modelling of the surface condenser is created by using high end solid modelling software CATIA as per the drawings supplied.

### 3.1 Description of the surface condenser

Water-cooled surface condenser modelled is used in power stations to condense the exhaust steam from a steam turbine driving an electrical generator as well in other applications. There are many fabrication design variations depending on the manufacturer, the size of the steam turbine, and other site-specific conditions.

Main components of the surface condenser are: a) Shell & hot well, b) Tube sheets, c) Dome assembly, d) End covers, e) Supporting legs, f) Cooling water inlet & outlet, g) Stand pipe and expansion pipe,

a) Shell & hot well: The shell is the condenser's outermost body and contains the heat exchanger tubes. The shell is fabricated from carbon steel plates and is stiffened as needed to provide rigidity for the shell. When required by the selected design, intermediate plates are installed to serve as baffle plates that provide the desired flow path of the

condensing steam. The plates also provide support that help prevent sagging of long tube lengths. At the bottom of the shell, where the condensate collects, an outlet is installed. In some designs, a sump (often referred to as the hot well) is provided. Condensate is pumped from the outlet or the hot well for reuse as boiler feed water. For most water-cooled surface condensers, the shell is under vacuum during normal operating conditions.

b) Tube Sheets: At each end of the shell, a sheet of sufficient thickness usually made of stainless steel is provided, with holes for the tubes to be inserted and rolled.

c) Dome Assembly: It is located at top of the shell where the steam exhaust enters the condenser downwards.

d) End covers plates: The ends of the shell are covered with end cover plates as shown in Fig. 1.

e) Supporting legs: supporting legs on which whole condenser assembly is mounted. Supporting legs are made up of Carbon Steel- SA 516 Gr 70 material.

f) Cooling water inlet & outlet: cooling water enters & exit from the condenser through inlet and out let provided as shown in the Fig.1.

g) Stand pipe and expansion pipe: These are the accessories attached to condenser and these shall be sent loose to site and to be assembled at site.

### 3. 2 Modelling of the surface condenser:

Solid modelling of the condenser is created by using the CATIA software. The overall dimensions of the surface condenser is shown in Fig.2.

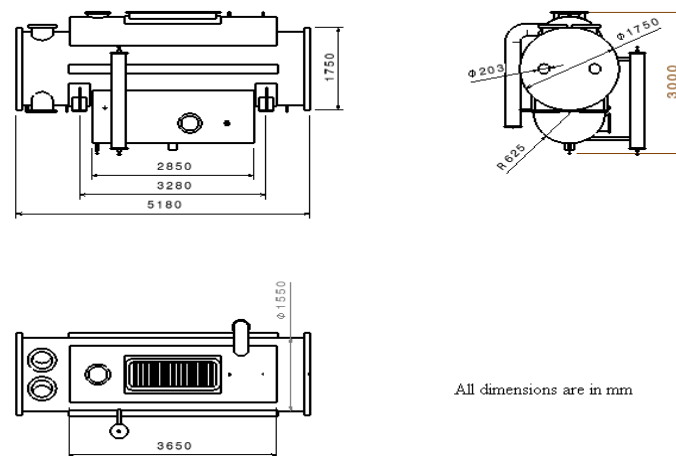

Fig. 2 Overall dimensions of the surface condenser

Fig. 3 from Fig. 6 show the isometric view, front view, top view and left side view of condenser model respectively.

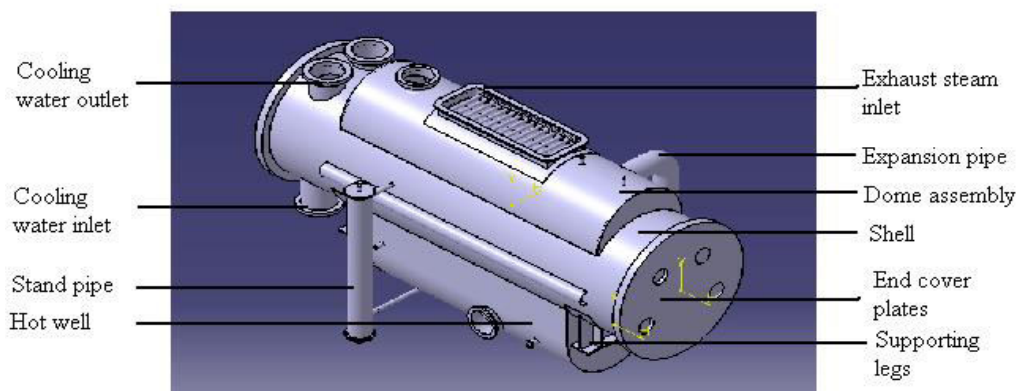

Fig. 3 Isometric view of the surface condenser along with different parts of the condenser

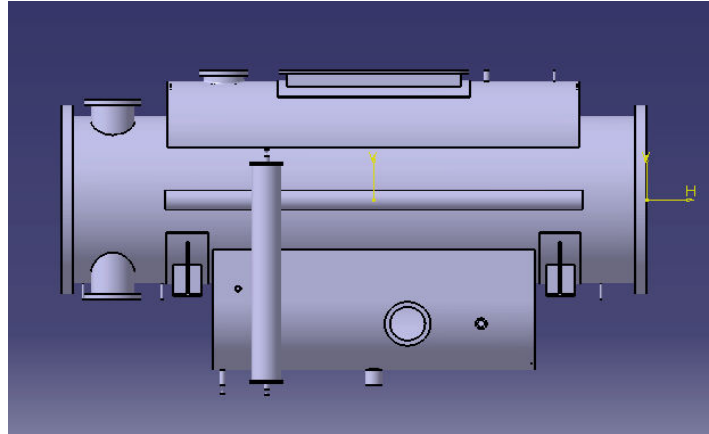

Fig. 4 Front view of the surface condenser

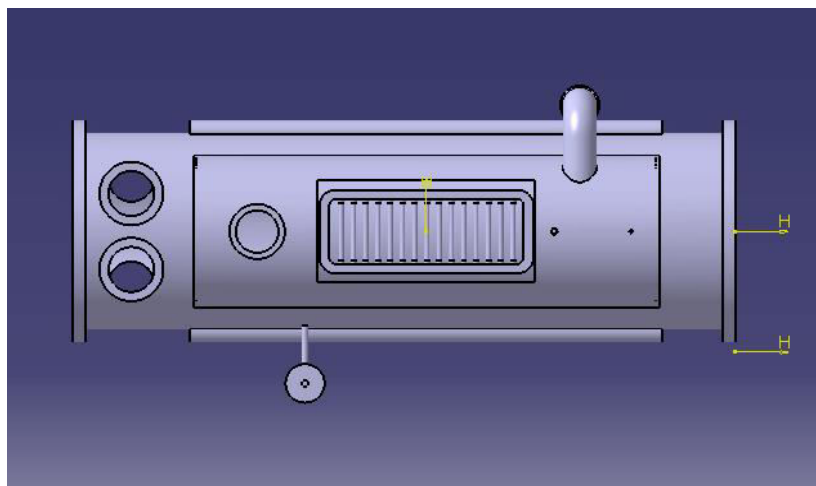

Fig. 5 Top view of the surface condenser

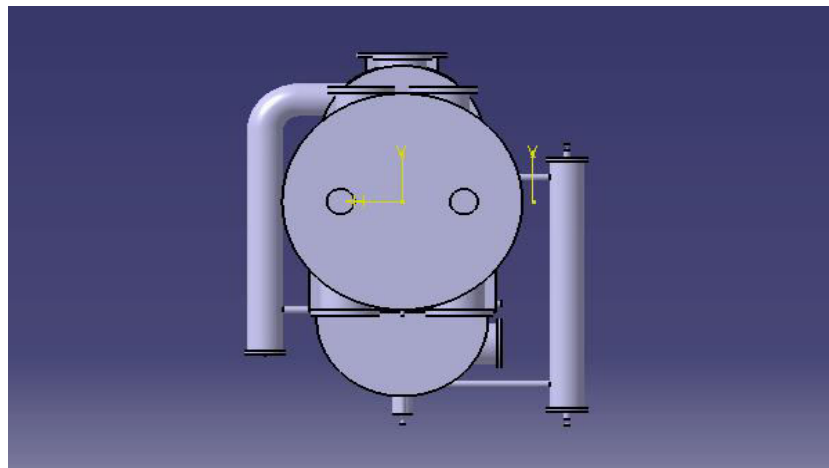

Fig. 6 Left side view of the surface condenser

### 3.3 Analysis of Condenser Using Ansys

This gives information about the methods that are used for structural analysis of condenser. Here in this problem, static analysis was carried out to know the strength of the condenser. Static analysis of the condenser is tested under maximum load conditions. Here the objective is, with the previous parameters, i.e. the dimensional parameters the structure is modelled in CATIA modelling software. The models can be meshed for further analysis using a meshing package HYPERMESH with shell and solid mesh and then exported to ANSYS. Meshing of the component plays an important role in analysis, as it is the basis for analyzing the component in any software package, which supports finite element techniques. The meshed component is imported into ANSYS software, which is being used broadly for analysis. According to the strength requirement carbon steel is considered. The material properties of Carbon Steel SA 516 Gr 70 are tabulated in the table 1.

**Table 1 Material properties of Carbon Steel- SA 516 Gr 70**

Material Properties	Magnitudes
Density, $\rho$ kg/mm <sup>3</sup>	7850e-9
Young's Modulus, E N/mm <sup>2</sup>	1.9e5
Poisson's Ratio, $\gamma$	0.3
Coefficient of Linear Thermal Expansion, $\alpha$	7.1e-6 / °c

### III.4 Meshing and Analysis of Condenser:

The modelling is done in modelling package CATIA and the finite element modelling and three dimensional analysis is carried out to obtain the stresses induced in isotropic Carbon steel- SA 516 Gr 70 loads acting internally and externally on the condenser. The models of the condenser are shown in the previous chapter with Fig. 5 and Fig. 6 The condenser analysis is carried out by creating the finite element model using the HYPERMESH software. The elements types used in condenser meshing are Quad4, HEXA8, Rigids and Tria3. Where ever the uniform thickness components such as shell, hot well, dome assembly are meshed with Quad4 shell elements. Components such as end cover plates, tube plates, supporting or baffles plates, supporting legs are meshed with HEXA8 solid elements. Complicated geometry such as rib ends are meshed with Tria3 elements. And also to achieve better mesh flow, smooth mesh transition we used the Tria3 and this is limited to within 5% of total elements. Rigid elements are used to connect the gap between the supporting leg saddle and shell. Elements used in condenser meshing are shown in table 2. The weld is modelled to be the actual Carbon steel- SA 516 Gr 70 material.

**Table 2 Element type and No. of element**

Element Type	Shell 63, Solid 45.
Rigid	276
Tria3	79
Quad4	46511
HEXA8	27932
Total No. of elements	74798

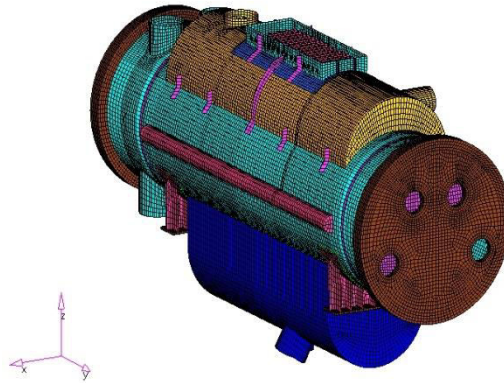

Fig. 7 The finite element model of the Condenser, isometric view

Table 3 Mesh quality parameters

Max Warpage	0.45°
Aspect Ratio	3.95
Skew	60°
Min. Angle of quad	35°
Max. Angle of quad	152°
Jacobian	0.55
Min angle of Trias	21°
Max angle of Trias	110°

**Constraints applied:**

Left side supporting leg is constrained in z-direction and all rotational DOF's and the right side supporting leg is constrained in DOF's. So that condenser should not break under applied loads. The finite element model of the baffles, tube sheets and supporting legs and end covers of the condenser as shown in Fig.8. Fig.9 show the condenser applied with constrained DOF's and coupled DOF's. Fig. 4 show the condenser subjected to design pressure of 0.1078 MPa.

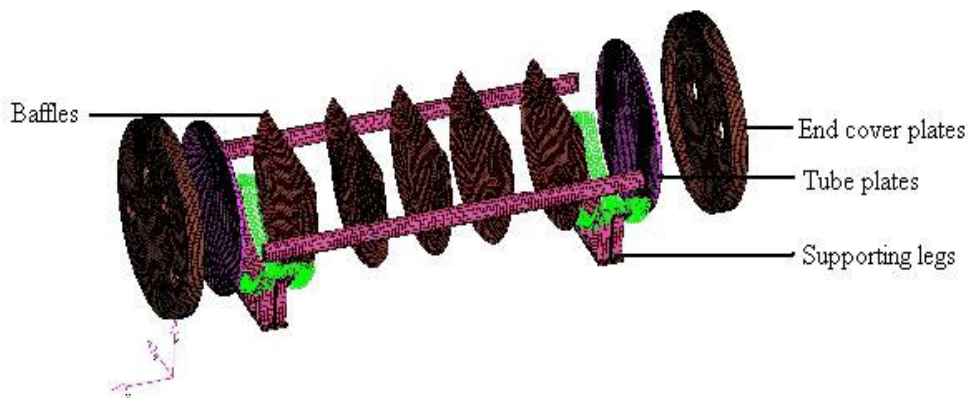

Fig. 8 Finite element model of the baffles, tube plates, supporting legs and end cover plates of Condenser.



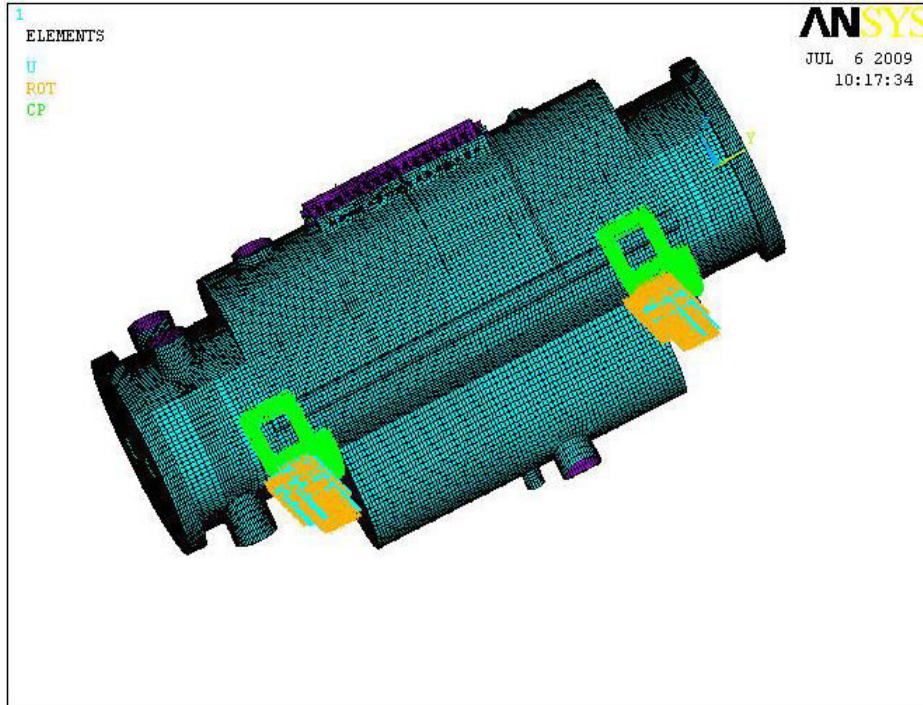

Fig. 9 Condenser with coupled DOF's (green colour) and constrained DOF's (orange colour),

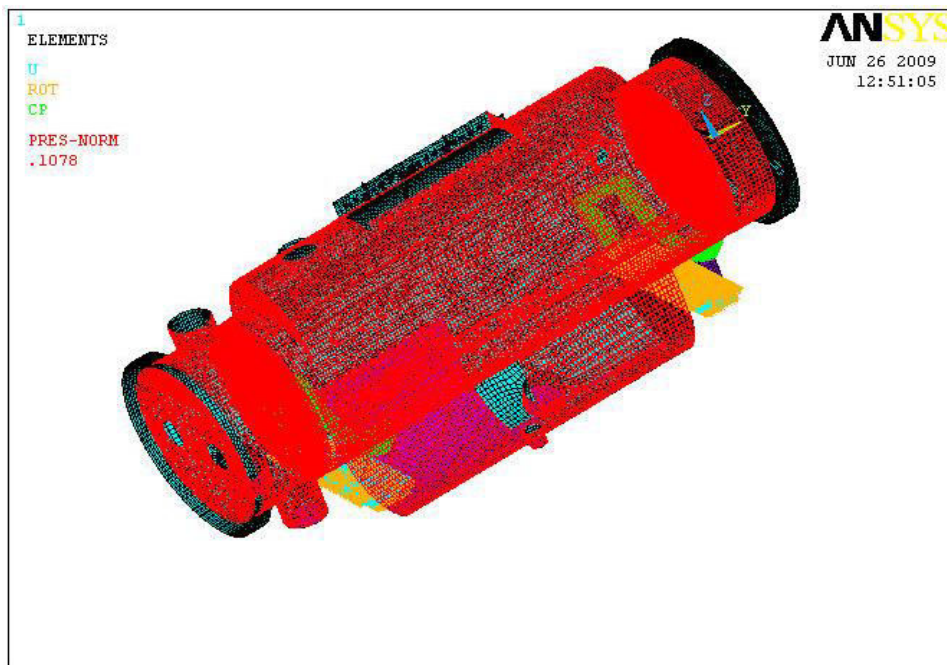

Fig. 10 Condenser subjected to pressure loading.

IV. EXPERIMENTAL RESULTS AND DISCUSSIONS

The static analysis of the surface condenser is carried out by applying the design pressure, full Vacuum pressure, hydrostatic pressure, thermal load, combined operational loading and the deflections and stress variation at different locations of the surface condenser analyzed.

4.1. Design Pressure:

This is the maximum pressure that can be induced with in the condenser at critical conditions and it is so called design pressure. If the condenser withstands this pressure then we can say that design is safe and practicable. Maximum design pressure given is 0.1078 MPa, with this pressure load, deflections and stresses are obtained.

Table 4 Induced displacements and stresses with Design Pressure of 0.1078Mpa

Description	Results as per Analysis	Allowable stress as per ASME SEC VIII DIV.2
Displacement in X- direction ,mm	1.163	7 mm
Displacement in Y-direction ,mm	0.796	7 mm
Displacement in Z-direction ,mm	0.482	7 mm
Shear Stress in XY plane , MPa	17.8	157.2
Shear Stress in YZ plane , MPa	31.5	157.2
Shear Stress in XZ plane , MPa	103	157.2
Stress Intensity , MPa	265	524

From the table 4 it is observed that the maximum stress induced is less than allowable stresses. Hence the design is safe as per the strength criteria. Fig 11 to Fig 13 show the variation of max displacement in x, y and z-direction respectively 1.163, 0.796 and 0.482 mm. The maximum allowable displacement is 7mm. Hence the design is safe based on rigidity.

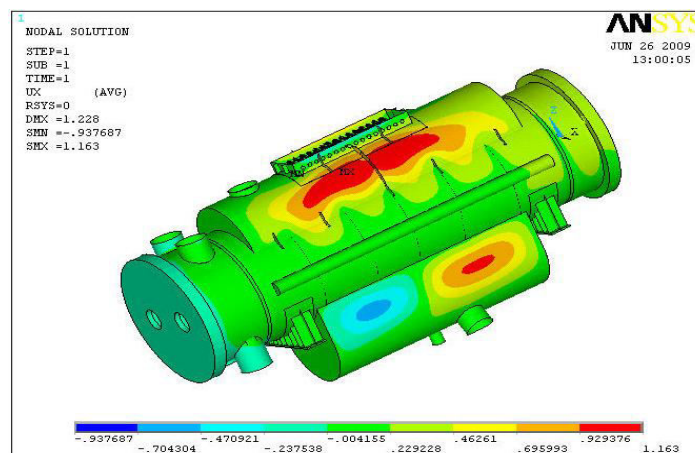

Fig. 11 Displacement in x-direction under design pressure

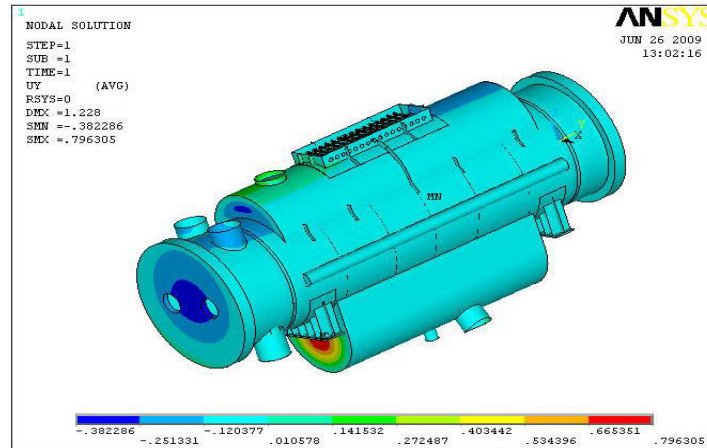

Fig. 12 Displacement in y-direction under design pressure.

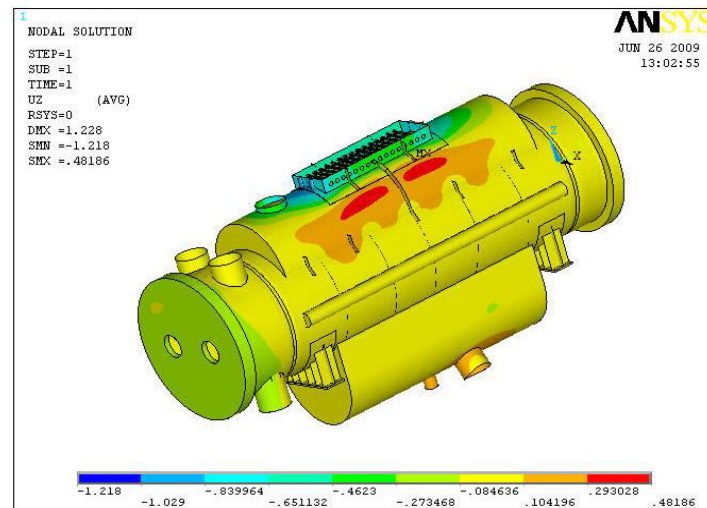

Fig. 13 Displacement in z-direction under design pressure

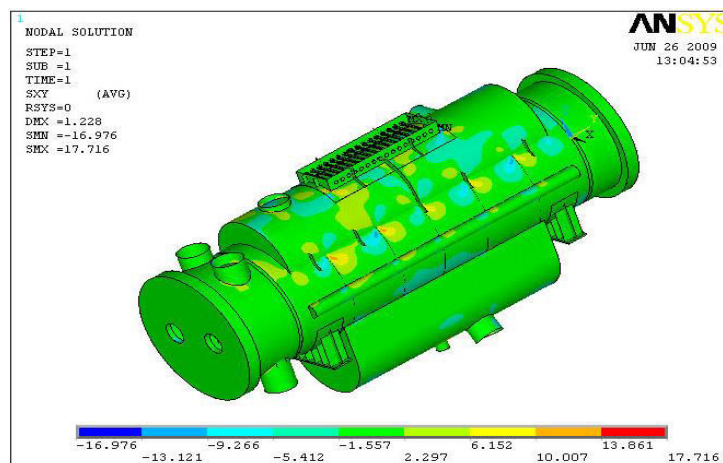

Fig. 14 Variation of Shear stress in xy-plane under design pressure.

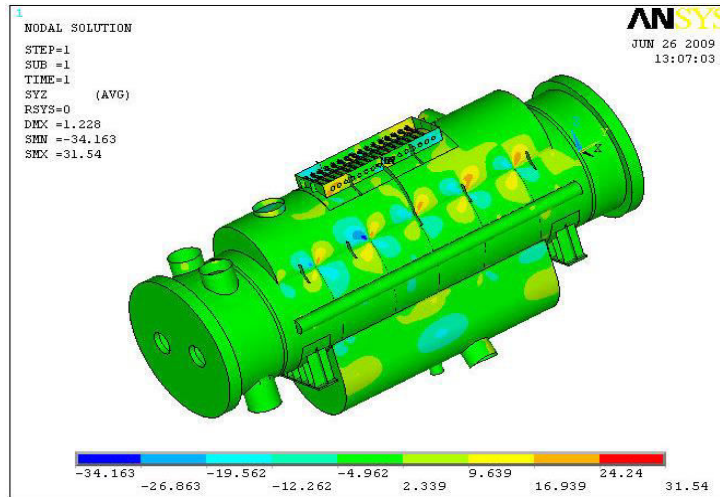

Fig.15 Variation of Shear stress in yz-plane under design pressure.

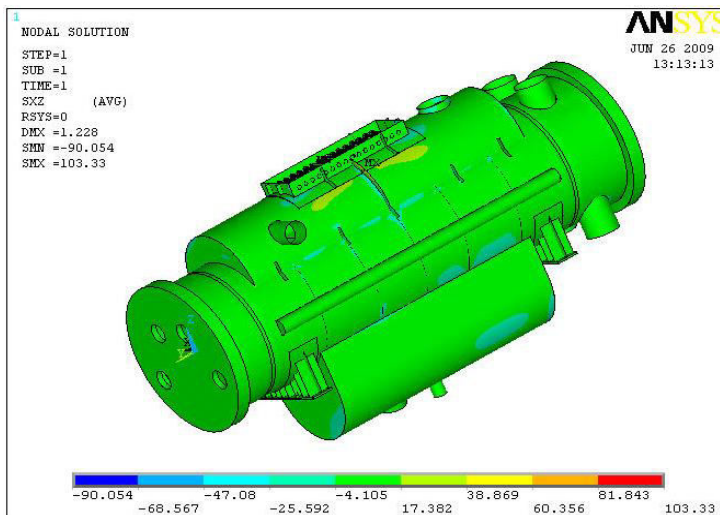

Fig. 16 Variation of Shear stress in xz-plane under design pressure

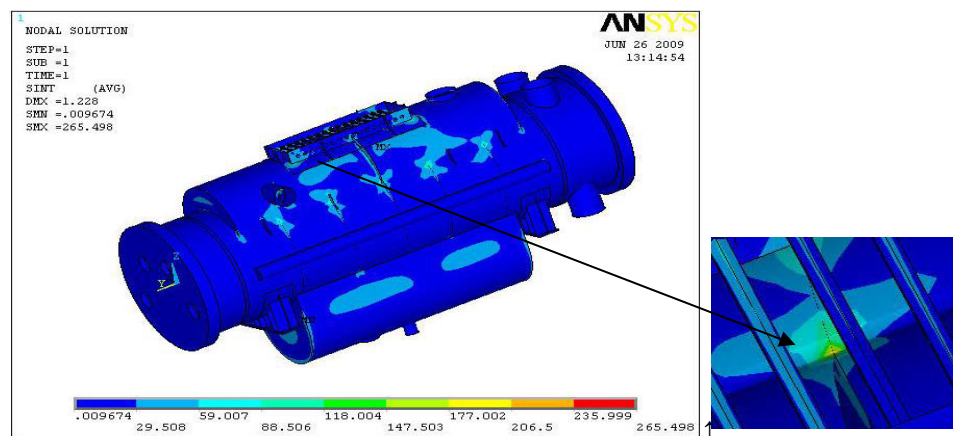

Fig.17 Variation of stress intensity under design pressure.

Fig. 14 to Fig. 17 show the variations of shear stress and stress intensity. From the figures it is observed that the maximum shear stress is 103.3 MPa and maximum stress intensity induced is 265 MPa, which is less than allowable stress.

## V. CONCLUSION

In this work, the condenser was modelled and analyzed by applying the design pressure, full Vacuum pressure, hydrostatic pressure, thermal loads and combined operational loading. The static analysis has been carried out to obtain the deflections and stresses.

Following conclusions are drawn from the present condenser analysis work:

The maximum deflection induced is 1.163mm along x- direction when the condenser is subjected to design pressure of 0.1078 MPa, which is within the allowable limits. The allowable limit as per ASME is 7 mm.

The maximum stress intensity induced is 265 MPa when condenser is subjected to design pressure of 0.1078 MPa, which is less than allowable limits of 524 MPa. The factor of safety estimated is 1.97.

The maximum deflection induced is 1.145 mm along z-direction when the condenser is subjected full Vacuum pressure of 0.10135 MPa which is within the allowable limits. The allowable limit as per ASME is 7 mm.

The maximum stress intensity induced is 245 MPa when the condenser is subjected to full Vacuum pressure of 0.10135 MPa, which is less than allowable limits of 524 MPa. The factor of safety estimated is 2.138.

The maximum deflection induced is 1.71 mm along the x-direction when condenser subjected to hydrostatic pressure of 0.157 MPa, which is within the allowable limits. The allowable limit as per ASME is 7 mm.

The maximum stress intensity induced is 381 MPa when the condenser is subjected to hydrostatic pressure of 0.157 MPa, which is less than allowable limits of 524 MPa. The factor of safety estimated is 1.375.

The maximum deflection induced is 3.004 mm along the y- direction when the condenser subjected to uniform temperature of 99 °C which is within the allowable limits. The allowable limit as per ASME is 7 mm.

The maximum stress intensity induced is 361 MPa when the condenser subjected to uniform temperature of 99°C, which is less than allowable limits of 524 MPa. The factor of safety estimated is 1.45.

The maximum deflection induced is 1.635mm along the y-direction when the condenser is subjected to combined operational loading of 0.09316 MPa and uniform temperature of 44.5 °C which is within the allowable limits. The allowable limit as per ASME is 7 mm.

The maximum stress intensity induced is 229 MPa when the condenser is subjected to combined operational loading of 0.09316 MPa and uniform temperature of 44.5 °C, which is less than allowable limits of 524 MPa. The factor of safety estimated is 2.28.

## REFERENCES

1. Gulyani, B. B., 2000, "Estimating Number of Shells in Shell and Tube Heat Exchangers: A New Approach Based on Temperature Cross," ASME J. Heat Transfer, 122, pp. 566-571.
2. Master, B. I. Chunangad, K. S., and Pushpanathan, V., 2003, "Fouling Mitigation Using Helixchanger Heat Exchangers," Proceedings of the ECI Conference on Heat Exchanger Fouling and Cleaning: Fundamentals and Applications, Santa Fe, NM, May 18-22, pp. 317-322.
3. Reppich, M., and Zagermann, S., 1995, "A New Design Method for Segmentally Baffled Heat Exchangers," Comput. Chem. Eng., 19, pp. 137-142.
4. Li, H. D., and Kottke, V., 1998, "Effect of the Leakage on Pressure Drop and Local Heat Transfer in Shell-and Tube Heat Exchangers for Staggered Tube Arrangement," Int. J. Heat Mass Transfer, 41 2 , pp. 425-433.
5. Doug, S., and Van der Ploeg, H. J., 1997, "Compact Exchanger to Reduce Refinery Fouling," PTQ Autumn, pp. 88-90.
6. Naim, A., and Bar-Cohen, A., 1996, New Developments in Heat Exchangers, Gordon and Breach, Amsterdam, pp. 467-499.
7. Van der Ploeg, H. J., and Master, B. I., 1997, "A New Shell-and-Tube Option for Refineries," PTQ Autumn, pp. 91-95.
8. Kral, D., Stelik, P., Van der Ploeg, H. J., and Master, B. I., 1996, "Helical Baffles in Shell-and-Tube Heat Exchangers, Part One: Experimental Verification," Heat Transfer Eng., 17 1 pp. 93-101.
9. Stehlik, P., Nemicansky, J., and Kral, D., 1994, "Comparison of Correction Factors for Shell-and-Tube Heat Exchangers With Segmental or Helical Baffles," Heat Transfer Eng. 15 1 , pp. 55-65.
10. Pekdemir, T., Davies, T. W., Haseler, L. E., and Diaper, A. D., 1994, "Pressure Drop Measurements on the Shell

- Side of a Cylindrical Shell-and-Tube Heat Exchanger,” Heat Transfer Eng., 15 3 , pp. 42–55.
11. Lutchka, J., and Nencansky, J., 1990, “Performance Improvement of Tubular Heat Exchangers by Helical Baffles,” Chem. Eng. Res. Des., 681, pp. 263–270.
  12. Wang, Q. W., 2004, “Current Status and Development of Shell-Side Heat Transfer Enhancement of Shell-and-Tube Heat Exchangers With Helical Baffles,” Journal of Xi’an Jiaotong University, 38 9 , pp. 1–6 in Chinese .
  13. Zhang, D. J., Wang, Q. W., Zeng, M., and Luo, L. Q., 2005, “Numerical Simulation of Flow Performance in Shell Side of Shell-and-Tube Heat Ex- changer With Discontinuous Helical Baffles,” 2005, Proceedings of the Second International Symposium on Thermal Science and Technology, Beijing, Oct.23–25, pp. 181–185.
  14. Zhang, Z., Yu, Z., and Fang, X., 2007, “An Experimental Heat Transfer Study for Helically Flowing Outside Petal-Shaped Finned Tubes with Different Geo- metrical Parameters,” Appl. Therm. Eng. 27 1, pp. 268–272.
  15. Wheeler, A. J., and Ganji, A. R., 2004, Introduction to Engineering, 2nd ed., Prentice-Hall, Englewood Cliffs, NJ.
  16. Ansys and Hypermesh help manuals.
  17. ASME data hand book.



INTERNATIONAL  
STANDARD  
SERIAL  
NUMBER  
INDIA



# INTERNATIONAL JOURNAL OF INNOVATIVE RESEARCH

IN SCIENCE | ENGINEERING | TECHNOLOGY

 9940 572 462  6381 907 438  [ijirset@gmail.com](mailto:ijirset@gmail.com)



[www.ijirset.com](http://www.ijirset.com)

Scan to save the contact details