



# International Journal of Innovative Research in Science Engineering and Technology (IJIRSET)

*(A Monthly, Peer Reviewed, Refereed, Scholarly Indexed, Open Access Journal)*



**Impact Factor: 8.699**

**Volume 14, Issue 2, February 2025**

# Review on Real Time Visitors Monitoring System to Enhance Security in Apartment

**Aditya Pattanashetti<sup>1</sup>, Siddesh Y P<sup>1</sup>, Umesh Nagarakatti<sup>1</sup>, Vivek R<sup>1</sup>, Raghavendra Babu T M<sup>2</sup>**

Department of CSE, P.E.S. College of Engineering, Mandya, Karnataka, India<sup>1</sup>

Assistant Professor, Department of CSE, P.E.S. College of Engineering, Mandya, Karnataka, India<sup>2</sup>

**ABSTRACT:** Visitor management in residential communities by automating key processes. The limitations of traditional access control systems pose significant security threats to apartment complexes. Unauthorized access to apartments poses a significant risk to resident safety and property. A cutting-edge access control system, leveraging advanced technologies, is necessary to ensure secure, efficient, and transparent entry management, mitigating security risks and enhancing resident experience. An innovative solution is required to provide real-time authentication, notification, and monitoring, thereby enhancing security, convenience, and peace of mind for residents.

**KEY WORDS:** Visitors Authentication System, Residential Security, Access Control, Automation, Resident Communication, AI, IoT, Smart Home, Data Privacy.

## I. INTRODUCTION

Security, authentication, and privacy are fundamental aspects of modern technology that ensure the protection of information and prevent unauthorized access. As digital transformation continues to reshape industries, the need for robust security mechanisms has become more critical than ever. Security refers to the implementation of measures to safeguard systems, networks, and data from threats, while authentication is the process of verifying the identity of users or devices before granting access. Privacy, on the other hand, focuses on controlling how personal information is collected, stored, and shared. With the increasing use of connected devices, such as smart systems and IoT-based solutions, security concerns have evolved beyond traditional threats. These devices interact with the physical world and process sensitive data; security, authentication, and privacy are essential for protecting data, maintaining user trust, and preventing cyber threats. As technological advancements continue, organizations and individuals must remain vigilant and adopt best practices to mitigate risks and ensure a secure digital environment. By integrating strong authentication mechanisms, enforcing data privacy regulations, and continuously monitoring security threats, a more resilient and secure technological landscape can be achieved.

## II. LITERATURE SURVEY

The author's M. Niharika, Rachankonda Saisr, Jilla Vaishnavi, Volam Meenakshi, Voruganti Navaneetha, Divya Gudibandla, proposed "Company Visitor Management System". The research paper "Company Visitor Management System" presents a web-based Visitor Management System (VMS) designed to streamline visitor entry, room bookings, and interactions through admin and user logins. Admins can manage rooms and bookings, while users can browse, book, and interact, replacing manual logs with an automated system for improved efficiency and security. The literature review highlights automated VMS approaches such as RFID, biometric authentication, IoT, face recognition, and cloud-based tracking, emphasizing the shift from manual to intelligent systems. The proposed IA VMS, built with the MERN stack (MongoDB, Express, React, Node.js), offers real-time visitor tracking, room booking, interactive features, and an event calendar. Future enhancements include Google Calendar integration, SMS/email notifications, and visitor analytics, making it a scalable and secure alternative to traditional manual systems[1]. According to Anurag Tiwari, Dr. Akhilesh A. Wao, an IoT-based smart door security system that transforms traditional door locks into connected devices, enhancing security and convenience. The system integrates electronic locks, IoT sensors, and a cloud platform for remote control, real-time monitoring, and secure data storage. By leveraging wireless communication and IoT-enabled sensors to track door status, motion, and environmental conditions, the system allows users to manage their security through mobile or web applications. The authors conclude that this IoT-based approach not only ensures robust security but also provides significant user control and convenience, with the potential for further advancements in technology to make such systems even more integral to modern living[2]. As per M. Niharika, Rachankonda Saisr, Jilla

Vaishnavi, Volam Meenakshi, Voruganti Navaneetha, Divya Gudibandla, proposed system “Company Visitor Management System”. Apartment Visitor Management System (AVMS) automates visitor tracking, authentication, and access control in apartment complexes. Visitors enter via OTPs or QR codes, with real-time tracking for security. Admins manage logs, reports, and access while ensuring secure authentication and alerts for suspicious activity. AVMS integrates with residents and security for real-time notifications. Future upgrades include AI threat detection, IoT-based touchless entry, and blockchain-secured logs. With a user-friendly interface, robust security, AVMS enhances safety and efficiency for buildings of all sizes[3]. Based on R F Rahman, I D Sumitra, proposed system “Realtime Notifications On Visitor Tracking System Using Android and Arduino”. Realtime Notifications on Visitor Tracking System integrates Android and Arduino to Provide instant security alerts. It automates visitor tracking using motion sensors and push notifications, reducing the need for manual monitoring. When a visitor enters a designated area, the Arduino microcontroller processes sensor data and sends real-time alerts to the user’s Android device via WiFi. This system enhances security by offering an efficient alternative to traditional CCTV and manual logs, ensuring seamless communication and real-time monitoring[4]. In accordance with Dr. Harish B.G, Bhavana R B about Visitor Management System (VMS) for Apartments digitally manages visitor identification using facial recognition for security and efficiency. It consists of three modules: Admin, who manages resident and visitor records; Security Staff, who capture visitor details, send real-time notifications, and enforce entry rules; and Residents, who receive visitor alerts and approve or deny entry. First-time visitors register via an Android app, providing personal details and a photo stored in a centralized database. Upon arrival, facial recognition verifies their identity, granting entry if matched; otherwise, re-registration is required. All interactions, including entry and exit times, are securely logged, enhancing security, reducing manual effort, and streamlining visitor management.[5]. In the words of Lipsha Behera, Akshay Bhoite, Saurabh Doshi, Janhvi Jaware, Karishma Badgujar, about "secure system for residential apartments to keep logs of visitors". Developing an Android-based application to enhance security in residential apartments by tracking visitor entries. The system uses biometric fingerprint scanning to register and verify visitor identities. First-time visitors create an account by entering personal details and undergoing biometric authentication, which is stored in a centralized database. Returning visitors are verified through fingerprint scanning, eliminating the need for manual entry. The system also allows security personnel to notify residents via SMS or offline calls for identity verification before granting access. This method ensures a secure, automated, and efficient visitor management process, reducing security risks and manual workload[6].

### III. METHODOLOGIES

IOT-based home security system that detects intrusions using pressure sensors. When a pressure change is detected, a signal is sent to a microcontroller, which triggers a camera to capture video footage. The recorded video data is transmitted via wi-fi to a cloud-based service, where it is stored and processed. The system then sends real-time alerts to users, ensuring immediate response to potential security threats. This setup enhances home security by providing automated monitoring, cloud storage, and instant notifications[13].

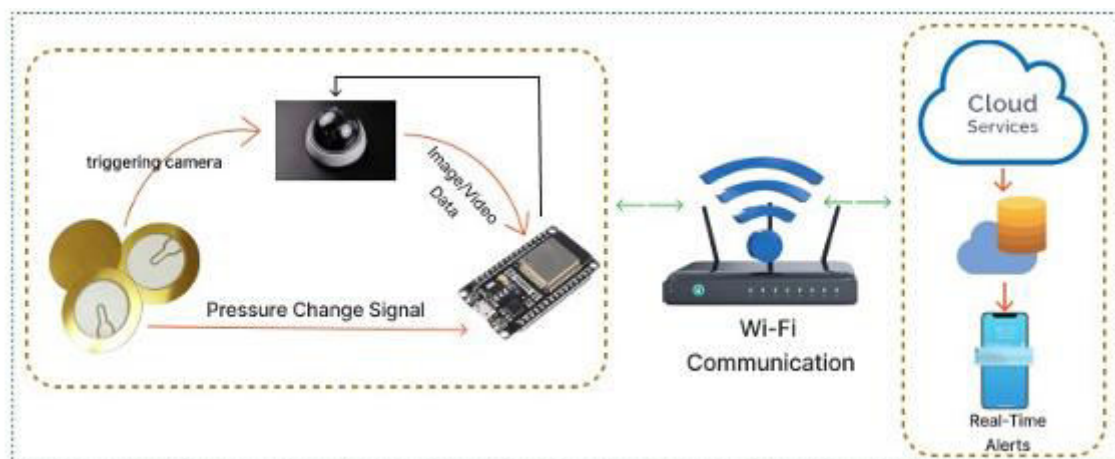

Fig 1: Smart home Security System architecture to detect intrusions

The proposed system utilizes facial recognition technology to enhance security by distinguishing between family members and visitors. The training phase involves storing family members' facial data in a database and training the system. During the testing phase, a camera captures a visitor's face, extracting facial features using the Grassmann algorithm. If a full face is detected, features are matched using a CNN-based algorithm against the stored database. If a match is found, the system alerts the family about the recognized person. If no match is found, an alert is sent for unknown visitors via SMS and email, and an alarm is triggered. The system also alerts users if a face mask obstructs detection, ensuring accurate recognition and enhanced home security[11].

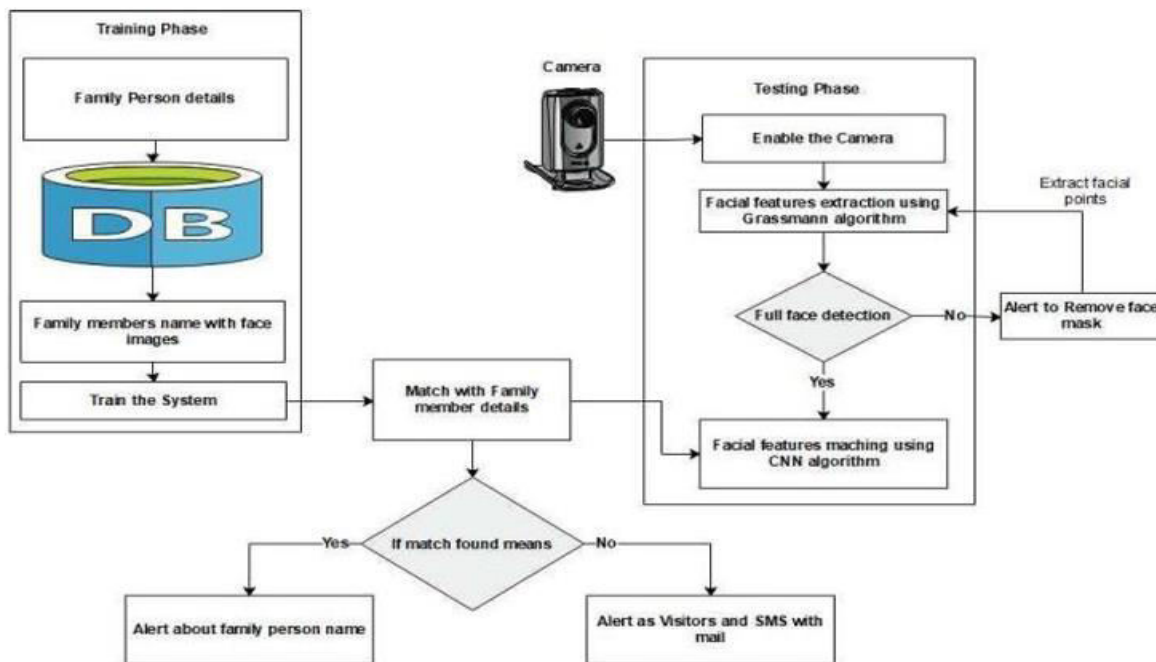

Fig 2: Grassman Algorithm to recognize unauthorized users

IOT-based home security system utilizes the esp8266 microcontroller, integrated with passive infrared (pir) and infrared (ir) sensors to detect intruders and unauthorized entry. The blynk application acts as the main switch, allowing users to control the system remotely from anywhere in the world. The microcontroller, equipped with an internet module, sends sensor data to the favoriot online database server, enabling real-time monitoring and alerts. An oled display provides local status updates, while a web server allows users to access the system via a smartphone. This cost-effective solution enhances home security by offering remote access, real-time notifications, and continuous monitoring, ensuring users can safeguard their homes even when they are away[10]. The system consists of a PIR motion sensor, a 16x2 LCD display, and a Wi-Fi connection to transmit alerts. When motion is detected, the Arduino processes the data, displays it on the LCD, and sends a push notification to the user's smartphone. The software is developed using the Arduino IDE in C++ and follows the System Development Life Cycle (SDLC) [4].

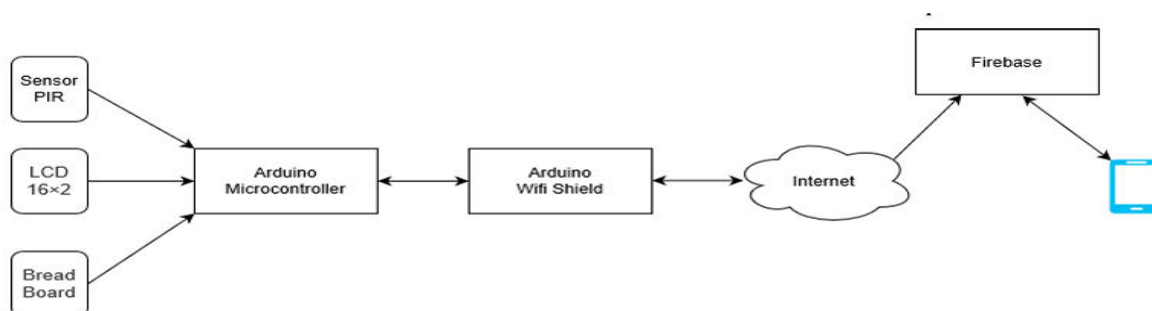

Fig 3: General System Design of real time visitor verification

The door security system for home monitoring based on iot uses raspberry pi, iot sensors, and a smart lock for enhanced security. It features pin, biometrics, and digital keys for authentication, with mqtt/coap protocols ensuring secure data transmission. A cloud platform like aws iot manages access logs and encryption. The android app enables remote door control, real-time monitoring, and alerts, while a camera and smart doorbell provide live video and two-way communication. This iot-based system offers remote access, security monitoring, and smart home integration for improved safety[1].

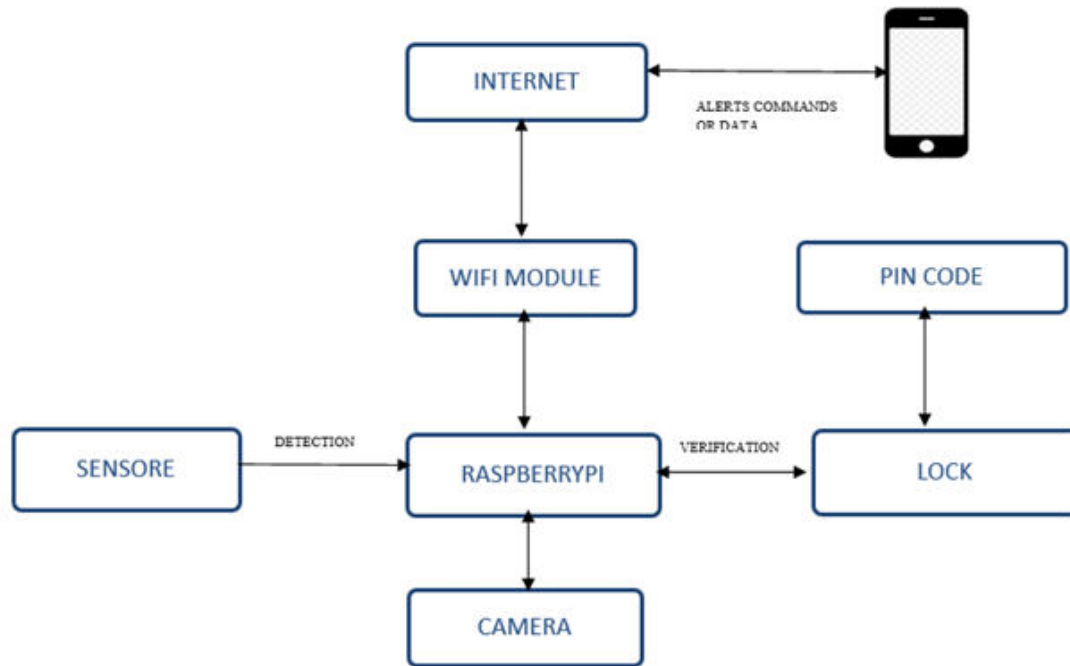

Fig 4: Iot system to monitor visitors

#### IV. CONCLUSION

The visitor access system prioritizes security and resident control. Upon arrival, a visitor provides information, which is then verified against resident data. If the resident is found, they are notified and given the ability to grant or deny access. This puts the resident in direct control of who enters the premises. If the resident approves, access is granted. Conversely, access is denied if the resident declines, or if the system cannot find the resident's information in the first place. This straightforward process ensures a secure environment by placing the authorization decision firmly in the hands of the resident.

#### REFERENCES

- [1]M. Niharika, Rachankonda Saisr, Jilla Vaishnavi, Volam Meenakshi, Voruganti Navaneetha, Divya Gudibandla, "Company Visitor Management System", (2023).
- [2] Anurag Tiwari, Dr. Akhilesh A. Wao, "Door Security System for Home Monitoring Based on Iot", (2024).
- [3]Sai Krishna Vennapusa, Karishma Shaik, Sai Sree Vardhan Vodnala, Veda Samhitha Seelam and Nidhi Shah, "Apartment Visitor Management System", March 27, (2024).
- [4]R F Rahman, I D Sumitra, "Realtime Notifications On Visitor Tracking Systems Using Android and Arduino", (2020).
- [5] Dr. Harish B.G , Bhavana R B , "Visitor's Management System for Apartments" , June 2022.
- [6]Lipsha Behera, Akshay Bhoite, Saurabh Doshi, Janhvi Jaware, Karishma Badgujar, "SECURE SYSTEM FOR RESIDENTIAL APARTMENTS TO KEEP LOGS OF VISITORS" December 2018.
- [7]Yogita Narule, Aryan Kashyap, Ayush Katore, Kashish Goel, Dhananjay Kasture, Sumedh Kate, "Apartment Residents Monitoring, Management and Security", volume 21 : issue 11 (nov) – 2022.
- [8]Behzad Shoarian Satari, Nor Azlina Abd Rahman, Zety Marla Zainal Abidin, "Face Recognition for Security

- Efficiency in Managing and Monitoring Visitors of an Organization”, 2014.
- [9]Vivek Gujar , “Enhancing Organizational Security and Efficiency: A Case Study of IndoAI's Visito - Visitor Management Systems App”, November 2023.
- [10]Mohd Azlan Abul, Siti Fatimah Nordin, Mohd Zubir Suboh, Mohd Syazwan Md Yid & Aizat Faiz Ramli, ” Design and Development of Home Security Systems based on Internet of Things Via Favoriot Platform”,2018.
- [11]Hajeera Thabasum A, Kabilan M, Gopinath K, Aravind R, Deekshitha K, “AI-Driven House Security System In Integration With Existing Security Setups”, Volume:06/Issue:03/March-2024.
- [12]Abhishek Dhar Dwivedi, Himalaya Gupta, Siddhant Tomar, Deepak Jaiswal, “Android Based Flat Security System -The Digital Unlocking And Locking System Based On Android For Smart Phone”, 2020.
- [13]Avhishek Nandi, Barnali Paul, Deepsubhra Guha Roy, “A IoT-based System for Enhanced Home Security using Intelligent Solutions”, 2024.
- [14]Umer Ijaz, Usama Ameer, Badar ul Islam, Abubaker Ijaz, Waqar Aziz, “IOT Based Home Security and Automation System”, 2016.



INTERNATIONAL  
STANDARD  
SERIAL  
NUMBER  
INDIA



# INTERNATIONAL JOURNAL OF INNOVATIVE RESEARCH

IN SCIENCE | ENGINEERING | TECHNOLOGY

 9940 572 462  6381 907 438  [ijirset@gmail.com](mailto:ijirset@gmail.com)



[www.ijirset.com](http://www.ijirset.com)

Scan to save the contact details