



International Journal of Innovative Research in Science Engineering and Technology (IJIRSET)

(A Monthly, Peer Reviewed, Refereed, Scholarly Indexed, Open Access Journal)



Impact Factor: 8.524

Volume 14, Issue 1, January 2025

Stock Market Share Price Detection and Forecasting using LSTM Deep Learning Technique

Nisha Kumari¹, Prof. Suresh S. Gawande²

M. Tech. Scholar, Department of Electronics and Communication, Bhabha Engineering Research Institute,
Bhopal, India¹

Guide, Department of Electronics and Communication, Bhabha Engineering Research Institute, Bhopal, India²

ABSTRACT: Stock market share price detection and forecasting play a critical role in financial decision-making, offering insights for investors, traders, and policymakers. Traditional methods often struggle to capture the inherent complexities and nonlinear patterns in financial time series data. This research leverages the Long Short-Term Memory (LSTM) deep learning technique, renowned for its ability to model sequential data effectively, to address these challenges. The study focuses on the development and implementation of an LSTM-based framework for stock price prediction, utilizing historical stock data as input. The model is designed to learn temporal dependencies and detect subtle trends, offering improved accuracy and reliability compared to conventional approaches. Performance metrics such as mean squared error (MSE) and root mean squared error (RMSE) are used to evaluate the predictive capability of the model. Key challenges, including data preprocessing, feature selection, and hyperparameter tuning, are discussed to provide a holistic view of the modeling process. The results demonstrate that LSTM outperforms traditional statistical methods, making it a promising tool for stock market analysis. This study contributes to the growing body of research in financial forecasting and highlights the potential of deep learning to revolutionize stock market prediction.

KEYWORDS: Stock Market, Long Short Term Memory (LSTM), Deep Learning (DL)

I. INTRODUCTION

In addition, stock price volatility prediction is a recent research area in time series, and it plays a vital role in decreasing investment threat. Although, stock price tendency not only relies on historical trend but also its correlated social characteristics. Moreover, world's economy is hugely dependent on the stock markets of every country since billions of dollars are traded each day. The stock market has non-linear and highly variable time series data, estimated based on time to obtain different activity status [1]. Generally, the stock market is referred to as a complex financial system, which involves various company stocks, and also changes in price are varying upon time for each company [2, 3].

Nowadays, stock markets play economic operations stock market index is a significant one to several stakeholders in the market. The stock market price imitates total present information based on the Efficient Market Hypothesis (EMH). Eventually, various sources are generally separated as quantitative data and qualitative description. The quantitative data includes turnover rate, historical prices and so on, and qualitative descriptions have social media posts, annual reports, news, announcements and so on. Generally, qualitative data is shapeless, and hence extraction of required signals from them is insignificant. Therefore, dealing with qualitative data is a challenging one [4].

Even though, the stock market prediction is considered a difficult and undecided issue because of different characteristics, namely noise, irregularities, daily market trends, political influence and insecurities present in the stock market. Alternatively, traders and investors rely upon trading analysis, past and present stock data. The stock market is considered as a dynamic financial system as it includes several elements or stocks and the price changes heavily depends on time [5].

Basically, stock market prediction includes exposure of market trends based on the time. Every stock market investor's plan is to improve the profit from their investments and decrease the correlated risks. Even though various factors, like political events, investor's sentiment, economic limitations and so on affect forecasting of the stock market index is highly significant for several stockholders in the market.

Besides, the overall economic development is majorly dependent on stock market, thus the analysis of behaviours and

future prediction is very useful for attaining economic targets. Consequently, the core ingredient of stock market prediction is a trading system, which includes various elements for prediction, trading policy and risk analysis. The main purpose of trading element is to generate a collection of stocks, which increases overall return with regards to the risk of stocks in a group [6, 7].

II. STOCK MARKET PREDICTION

In basic, forecasting behaviors are separated into three levels, such as short, medium and long. Furthermore, stock market movements are influenced by various macroeconomical aspects, like bank exchange rate, commodity price index, investors' expectations, bank rate, general economic conditions, investor's psychology, firms' policies, institutional investors' choices, political events and so on [8, 9]. Additionally, stock value indices are computed using higher market capitalization stocks, whereas several technical parameters are also employed to obtain statistical information about stock price values [10]. In the stock market, there are two assumptions for predicting stock price value. The first one is EMH stating at any time, stock price completely confines all identified information about stock where all identified information's are utilized through market participants and also random price variations obtains new random information's.

Therefore, stock prices execute a random walk, that is every future price does not follow any patterns or trends. This assumption deduces fluctuations, so incomplete or delayed information controls the stock market prices. In addition, an exterior incident influences successive stock market prices, although the precise prediction of a stock price is complex. From the prediction perception, it can be categorized into two types, namely stock price trend and stock price forecast. The stock price trend is also named as classification, and stock price forecast is also termed as regression [11]. Basically, the time duration for stock price trend prediction is highly related with previously selected features [7].

Because of the identification of suitable movement of stock price decreases the risk of future trend calculation. The industry, economy and other correlated features are considered to compute the intrinsic value of a company, which helps to forecast stock prices from fundamental analysis method. Stock market decision-making technique is a very complex and significant job because of unstable and complex nature of the stock market. It is necessary to discover a huge quantity of valuable information created through the stock market. In addition, every investor has an imminent requirement for identifying future behaviours of stock prices.

Although, it helps the investors to achieve the best profit by identifying the best moment to sell or buy stocks. Normally, trading in stock market can be performed electronically or physically. The investor becomes the owner or partnership of a particular company, while an investor obtains a particular company share. Furthermore, financial data of the stock market is very complex in nature, so for predicting stock market behaviour is also complex. The stock market prediction helps the investors to take investment decisions by offering strong insights regarding stock market behaviour for reducing investment risks.

III. PROPOSED METHODOLOGY

Long-term dependencies can lead to explosions or disappearing gradients, which can be solved with the help of the LSTM model, a recurrent neural system developed to deal with these issues. Memory blocks, the building blocks of the LSTM architecture are a collection of recurrently linked sub-networks. Nonlinear gating units are used to preserve the memory block's state over time and to control the flow of information through it. The cell can recall values for arbitrary periods of time, and the cell's three gates are responsible for regulating the flow of information connected with it. The stock market is where shares of stock are traded, exchanged, and circulated. Although it's a legal and sensible way to move money, issuing stock also gives companies an opportunity to collect a big quantity of idle cash. The organic composition of business capital can be improved, and the growth of the economy can be considerably aided by such efficient capital accumulation. As a result of this, the collection of capital and the accumulation of capital are effectively fostered by the movement of stock. Deep learning using neural networks has gotten a lot of interest from researchers. A complicated nonlinear dynamic system like a neural network could be the only way to cope with the poor efficiency of a complex nonlinear system [11].

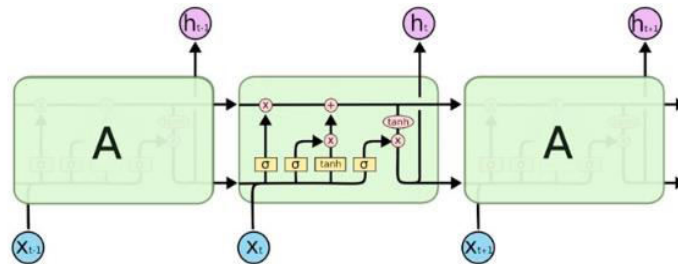

Fig. 1: The internal structure of an LSTM

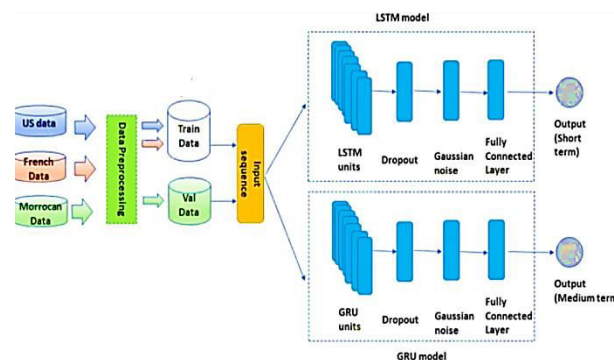

Fig. 2: Flow Chart of Proposed Methodology

The ability of LSTM architectures with multiple hidden layers is to represent sequential data at a higher level and hence perform more efficiently and accurately. The model's hidden layer output is sent straight into the input of the next hidden layer in its architecture, which consists of numerous stacked LSTM layers. A series of values is provided instead of the usual multilayer LSTM design in which each layer outputs a single value to the following layer. LSTM networks operate exceptionally well with sequence data and long-term dependencies because of its robust learning and memory processes. Those were able to increase memory capacity and exert control over memory cells by inserting gates. The output gate is the only gate responsible for reading data from the cell. In addition to the output gate, another gate is required to determine when data should be read into the cell [12].

$$f_t = \sigma(w_f[h_{t-1}, x_t] + b_f) \tag{1}$$

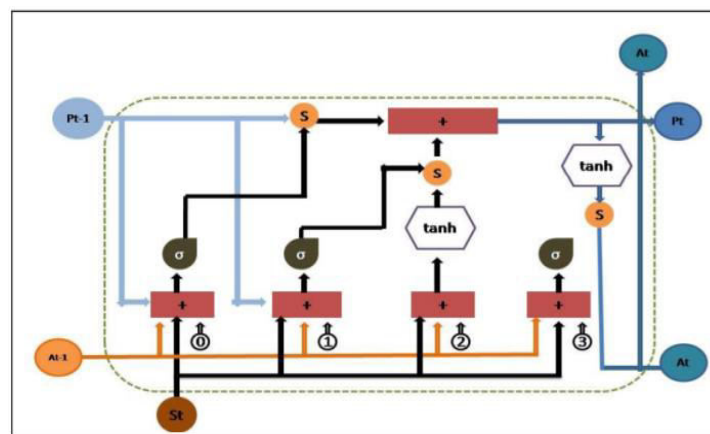

Fig. 3: Working of LSTM

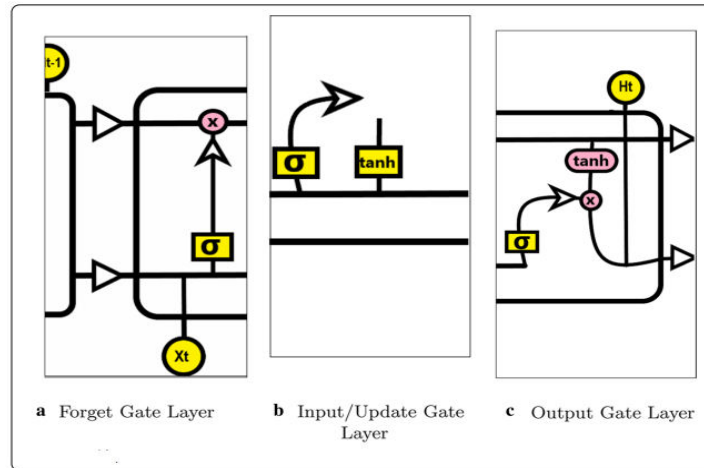

Fig. 4: LSTM Layer

$$i_t = \sigma(w_i[h_{t-1}, x_t] + b_i) \tag{2}$$

and

$$\tilde{C}_t = \tanh(w_c[h_{t-1}, x_t] + b_c) \tag{3}$$

Stock index values and the index's daily direction of movement were studied in a series of experiments. ANN cannot be capable of learning data patterns consistently and can operate inconsistently and unpredictably when using complicated financial data. Neuronal structures and the brain's internal workings are mirrored in ANN. Multiple layers of parallel processing use a slew of basic, coupled linear and nonlinear computing units.

$$O_t = \sigma(w_o[h_{t-1}, x_t] + b_o) \tag{4}$$

and

$$h_t = O_t \times \tanh(C_t) \tag{5}$$

Update gate:

$$z_t = \sigma(W_z * [h_{t-1}, x_t])$$

Reset gate:

$$r_t = \sigma(W_r * [h_{t-1}, x_t])$$

Table 1: Training parameter data of LSTM

Model	Sequential – RNN
Type	LSTM
Hidden Units	7
Input shape	1,1
Verbose	False
Output layer	(TimeDistributed(Dense(1)))
Loss Function	MAE (Mean Absolute Error)
Optimizer	ADAM
Compilation Time	0.01620 S
Total params	260
Trainable params	260
Non-trainable params	0
Epoch	100
Batch size	128

A constraint on LSTM ability to learn data patterns has been established in various applications. Researcher can exhibit erratic and unexpected behavior because of the intricate nature of the financial data. Learning patterns cannot operate in situations when the amount of data is too great [13].

Algorithm:

Wipro dataset using Enhanced LSTM
 Input: Wipro data set with class labels
 Output: Classification of Wipro

- Step 1: Pre-processed Wipro Dataset taken in the form of .csv file, data set is loaded
- Step 2: Tagging the Wipro Dataset
- Step 3: Tagged Wipro Dataset converted into vectors (word2vector conversion)
- Step 4: Apply Evolutionary algorithm on the vectors to select the best feature set
- Step 5: Enhanced-LSTM performs training only on the best features set selected by Evolutionary Algorithm and obtains a Model
- Step 6: Testing data set is supplied to the Model obtained by Enhanced LSTM
- Step 7: Evaluate the performance of this model based on some parameters

IV. SIMULATION RESULTS

Stock prices are extremely unpredictable; this complexity is a major draw for researchers and statisticians looking for a technique to anticipate them. Despite the numerous study articles and techniques in this area, many people believe that stock markets cannot be predicted. This is primarily due to the large number of factors that influence stock values, many of which are dependent on other potentially unknown factors.

index	Date	Open	High	Low	Close	Adj Close	Volume	close_10	close_50	Daily Return
0	2009-04-01	1.945584	1.988403	1.846566	1.950937	1.741724	2010700	NaN	NaN	NaN
1	2009-04-02	2.020517	2.231936	2.020517	2.138269	1.908966	4177593	NaN	NaN	0.096022
2	2009-04-03	2.106155	2.312221	2.106155	2.261374	2.018871	3325633	NaN	NaN	0.057572
3	2009-04-06	2.269402	2.269402	2.151650	2.231936	1.992589	2361200	NaN	NaN	-0.013018
4	2009-04-07	2.207850	2.207850	2.124888	2.148974	1.918524	1619471	NaN	NaN	-0.037170

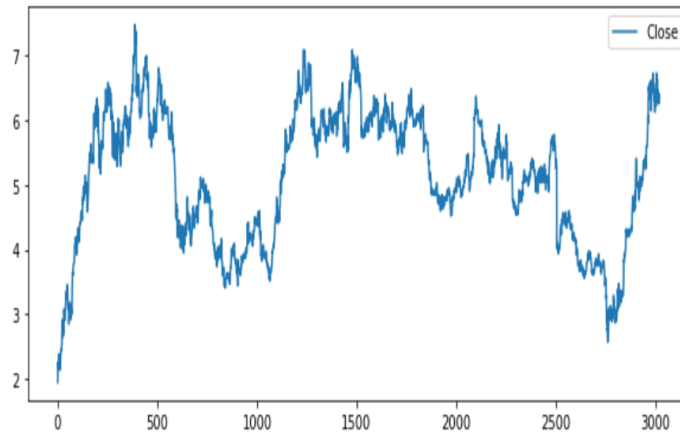

Fig. 5: Closing Price of Perform Exploratory Data Analysis

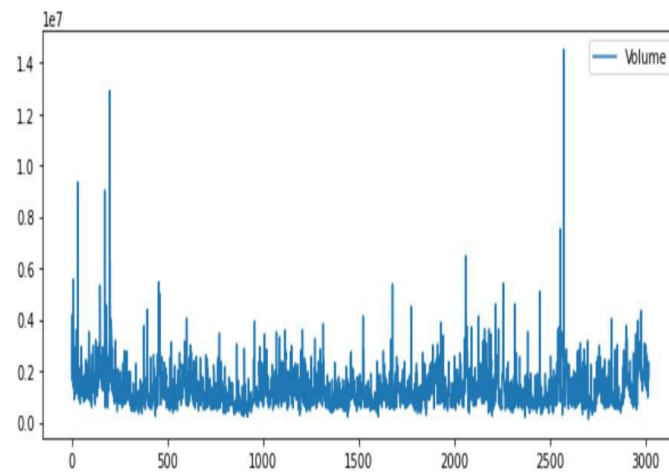

Fig. 6: Volume of Perform Exploratory Data Analysis



Fig. 7: Wipro Closing Price of Perform Exploratory Data Analysis

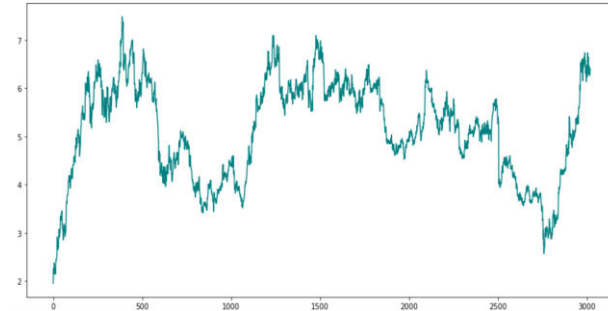

Fig. 8: Wipro Daily Return of Perform Exploratory Data Analysis

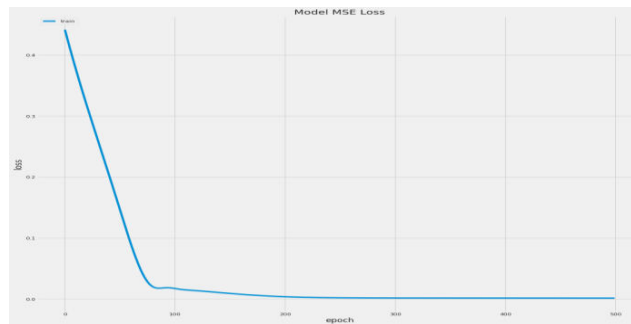

Fig. 9: Model Losses of Perform Exploratory Data Analysis



Fig. 10: Prediction and Forecast of Perform Exploratory Data Analysis

V. CONCLUSION

This research demonstrates the efficacy of Long Short-Term Memory (LSTM) networks in stock market share price detection and forecasting, highlighting their capability to capture temporal dependencies and complex patterns in financial time series data. Compared to traditional statistical models, LSTMs offer significant advantages in handling nonlinearities and sequential relationships, making them well-suited for predicting stock price trends.

The experimental results underscore the potential of LSTM models to achieve higher accuracy and reliability in stock price forecasting. However, challenges such as data preprocessing, feature selection, and hyperparameter optimization remain critical to achieving optimal performance. The integration of additional data sources, such as sentiment analysis

or macroeconomic indicators, could further enhance predictive accuracy but introduces additional complexities in model design and computation.

Future research should focus on addressing these challenges by exploring hybrid models, real-time forecasting systems, and improved interpretability techniques. By leveraging the strengths of LSTMs and incorporating advancements in deep learning, this work sets the stage for more robust and practical solutions in financial forecasting, contributing to informed decision-making in the dynamic world of stock markets.

REFERENCES

1. Himanshu Gupta and Aditya Jaiswal, "A Study on Stock Forecasting Using Deep Learning and Statistical Models", arXiv, 2024.
2. Yun, K.K.; Yoon, S.W.; Won, D. Interpretable stock price forecasting model using genetic algorithm-machine learning regressions and best feature subset selection. *Expert Syst. Appl.* 2023, 213, 118803.
3. Malki, A.; Atlam, E.-S.; Hassani, A.E.; Ewis, A.; Dagnew, G.; Gad, I. SARIMA model-based forecasting required number of COVID-19 vaccines globally and empirical analysis of peoples' view towards the vaccines. *Alex. Eng. J.* 2022, 61, 12091–12110.
4. Cheng, Y.; Yi, J.; Yang, X.; Lai, K.K.; Seco, L. A CEEMD-ARIMA-SVM model with structural breaks to forecast the crude oil prices linked with extreme events. *Soft Comput.* 2022, 26, 8537–8551.
5. Chatterjee, A.; Bhowmick, H.; Sen, J. Stock Price Prediction Using Time Series, Econometric, Machine Learning, and Deep Learning Models. In *Proceedings of the 2021 IEEE Mysore Sub Section International Conference (MysuruCon)*, Hassan, India, 24–25 October 2021; pp. 289–296.
6. Shraavan Raviraj, Manohara Pai M M. and Krithika M Pai, "Share price prediction of Indian Stock Markets using time series data - A Deep Learning Approach", *IEEE Mysore Sub Section International Conference (MysuruCon)*, IEEE 2021.
7. J. J. Duarte S. M. Gonzalez and J. C. Cruz "Predicting stock price falls using news data: Evidence from the brazilian market", *Computational Economics* vol. 57 no. 1, pp. 311-340, 2021.
8. Andrea Bucci, "Cholesky-ANN models for predicting multivariate realized volatility", *Journal of Forecasting*, vol. 39, no. 6, pp. 865–876, 2020.
9. Sarat Chandra Nayak and Bijan Bihari Misra, "Extreme learning with chemical reaction optimization for stock volatility prediction", *Financial Innovation*, vol. 6, no. 1, 2020.
10. Andrés Vidal and Werner Kristjanpoller, "Gold volatility prediction using a CNN-LSTM approach", *Expert Systems with Applications*, 157, 113481, 2020.
11. J Jia Zhai, Yi Cao, and Xiaoquan Liu, "A neural network enhanced volatility component model", *Quantitative Finance* vol. 20, no. 5, pp. 783–797, 2020.
12. Omer Berat Sezer, Mehmet Ugur Gudelek, and Ahmet Murat Ozbayoglu, "Financial time series forecasting with deep learning: A systematic literature review: 2005–2019", *Applied Soft Computing*, vol. 90, 106181, 2020.
13. G. Ding and L. Qin "Study on the prediction of stock price based on the associated network model of lstm" *International Journal of Machine Learning and Cybernetics* vol. 11 no. 6 pp. 1307-1317 2020.
14. S. T. Z. De Pauli M. Kleina and W. H. Bonat "Comparing artificial neural network architectures for brazilian stock market prediction" *Annals of Data Science* vol. 7 no. 4 pp. 613-628 2020.
15. Zhihao PENG, "Stocks Analysis and Prediction Using Big Data Analytics", *International Conference on Intelligent Transportation, Big Data & Smart City (ICITBS)*, IEEE 2019.
16. Eduardo Ramos-Pérez, Pablo J. Alonso-González, and José Javier Núñez-Velázquez, "Forecasting volatility with a stacked model based on a hybridized artificial neural network. *Expert Systems with Applications*", 129, pp. 1–9, 2019.
17. A. Site D. Birant and Z. Isik "Stock market forecasting using machine learning models", *Innovations in Intelligent Systems and Applications Conference (ASYU)* pp. 1-6, 2019.
18. Werner Kristjanpoller R. and Esteban Hernández P. "Volatility of main metals forecasted by a hybrid ANNGARCH model with regressors", *Expert Systems with Applications* 84, pp. 290–300, 2017.
19. Rodolfo C. Cavalcante, Rodrigo C. Brasileiro, Victor L. F. Souza, Jarley P. Nobrega, and Adriano L. I. Oliveira, "Computational intelligence and financial markets: A survey and future directions. *Expert Systems with Applications*", 55, pp. 194–211, 2016.
20. Salim Lahmiri, "A variational mode decomposition approach for analysis and forecasting of economic and financial time series. *Expert Systems with Applications*", 55, pp. 268–273, 2016.



INTERNATIONAL
STANDARD
SERIAL
NUMBER
INDIA



INTERNATIONAL JOURNAL OF INNOVATIVE RESEARCH

IN SCIENCE | ENGINEERING | TECHNOLOGY

 9940 572 462  6381 907 438  ijirset@gmail.com



www.ijirset.com

Scan to save the contact details